

SupraVac 2000

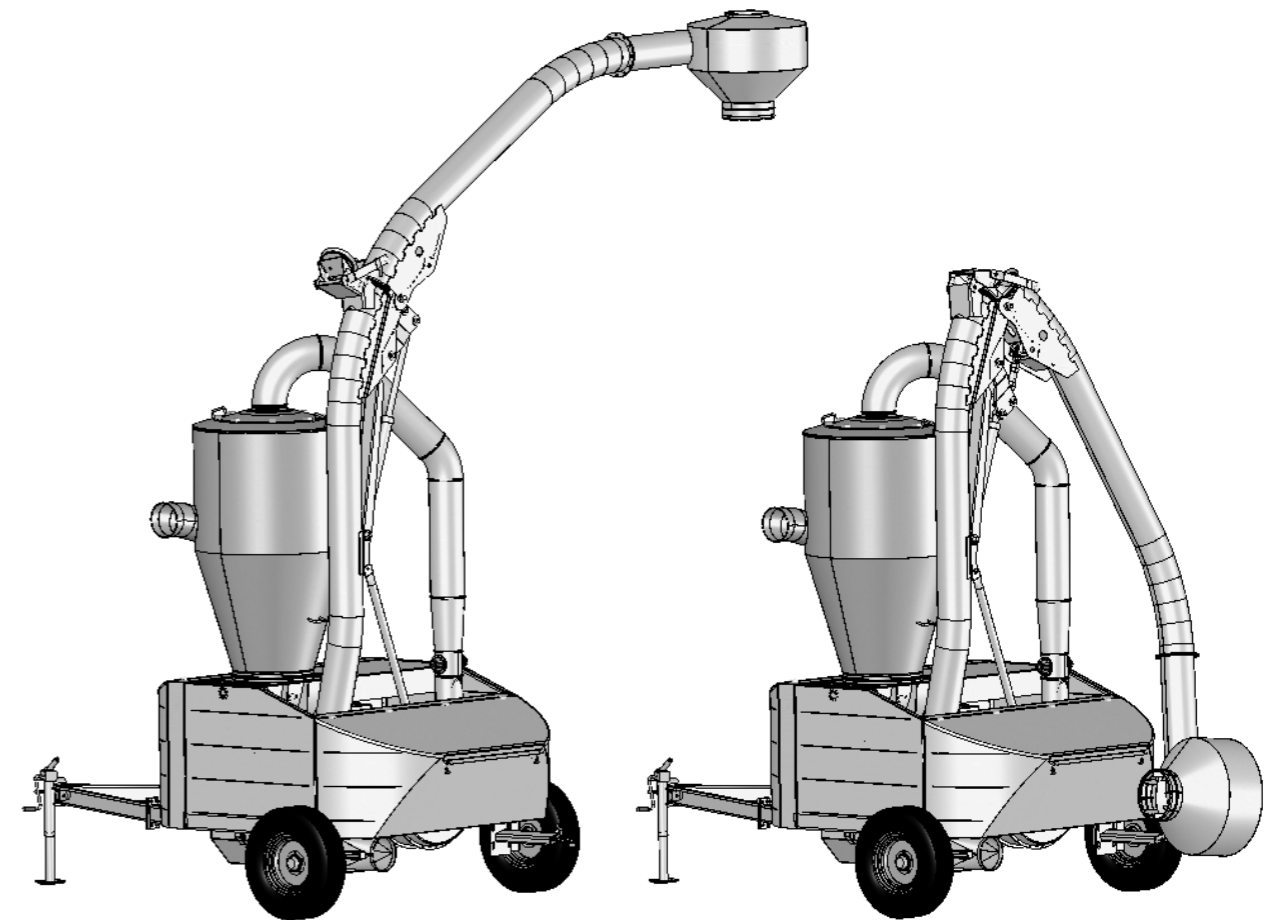

**Reservedelsliste
Spare parts list
Ersatzteilliste
Onderdelenlijst
Liste de pièce de rechange
Lista dei pezzi di ricambio**

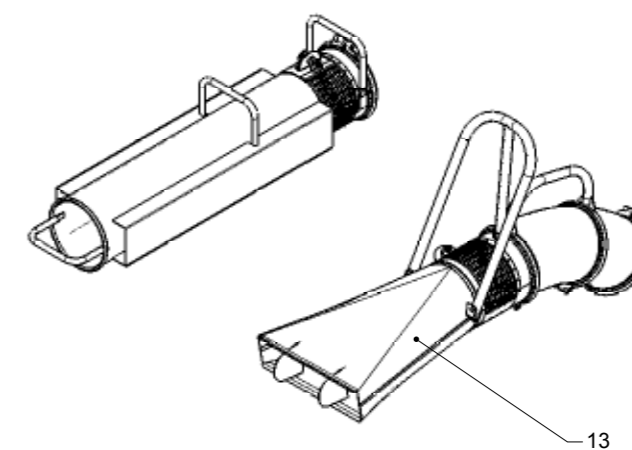
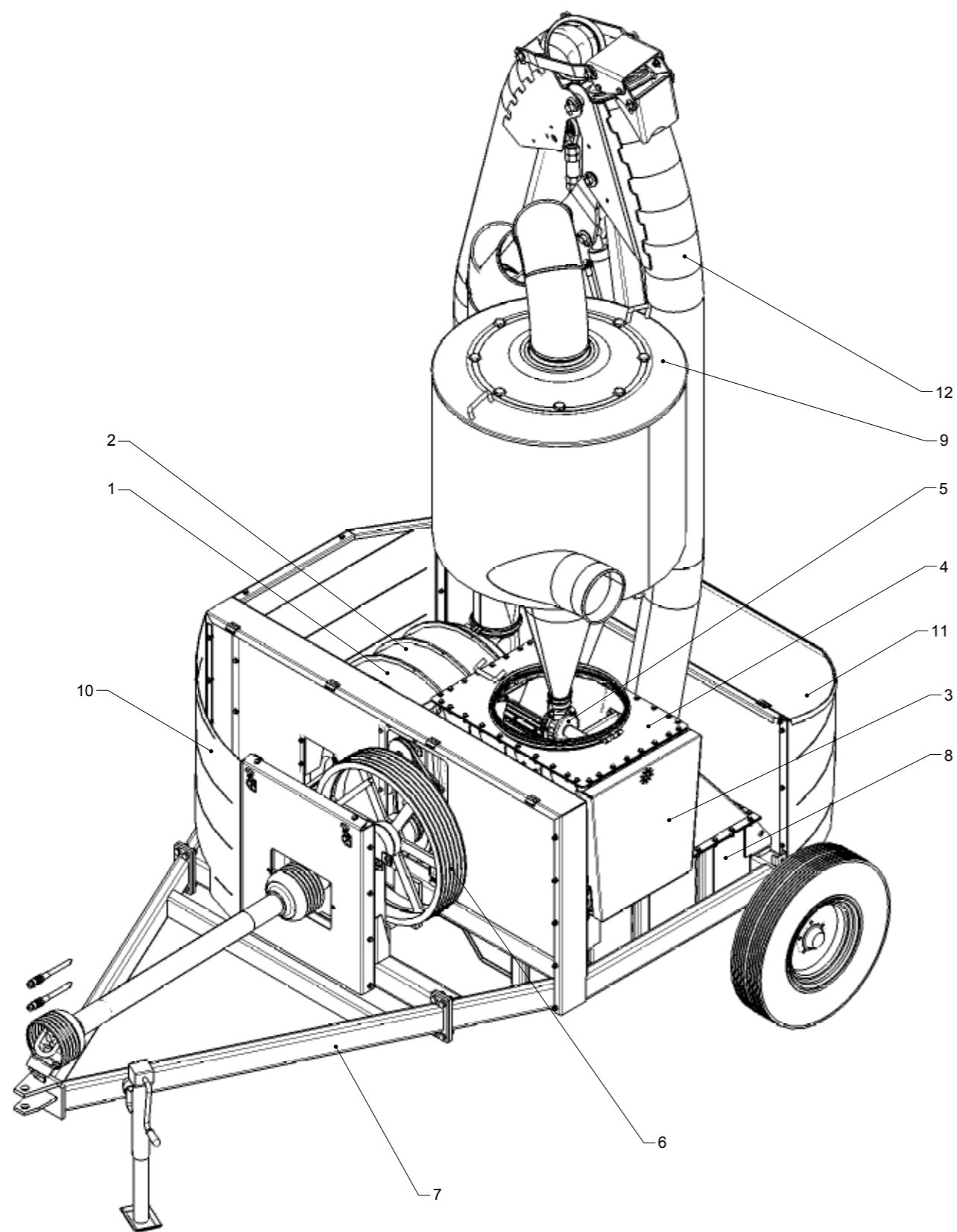

	Pos.	Spare parts list - page	Notes
1	1	121165450-04-05	Blower shaft
1	2	121165450-06-07	Blower housing
1	3	121165450-08-09	Rotary valve CA75
1	4	121165450-10-11	Rotary valve CA75
1	5	121165450-12-13	Dust rotary valve
1	6	121165450-14-15	Transmission
1	7	121165450-16-17	Trailer
1	8	121165450-18-19	Outlet CA 75
1	9	121165450-20-21	Cyclone
1	10	121165450-22-23	Gaurd for transmission
1	11	121165450-24-25	Tool box
1	12	121165450-26-27	Loading equipment
1	13	121165450-28-29	Suction heahs

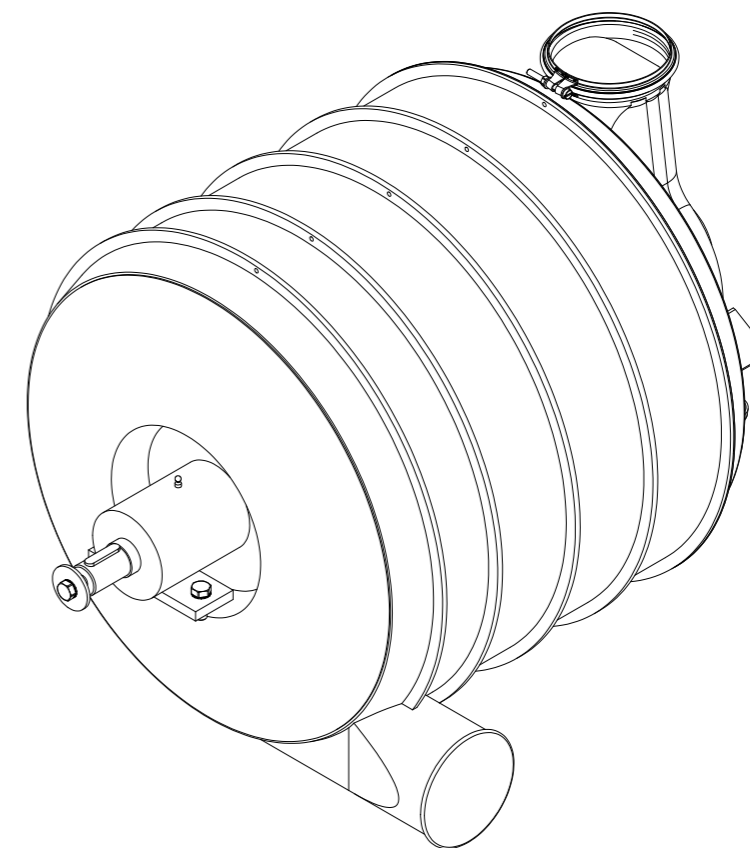
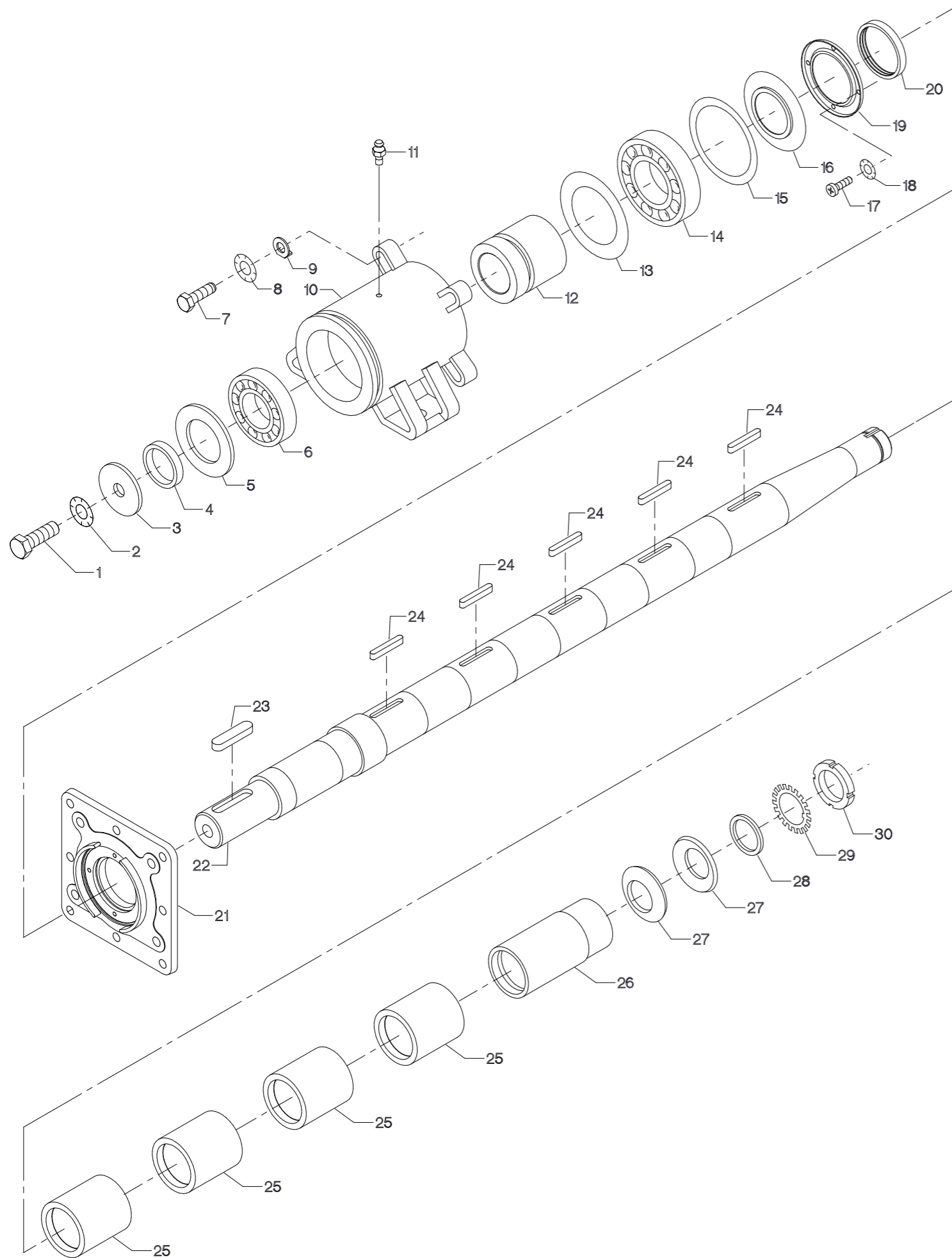

Pos.	Pieces	Part no.	Notes
1	1	100 306 056	Set screw M16 x 45 mm
2	1	100 332 006	Star washer M16
3	1	121 121 079	Flat washer ø65/17 x 5 mm
4	1	121 150 242	Spacer
5	1	100 413 065	
6	1	100 402 002	Ball bearing # 22210 CC C3
7	4	100 304 033	Set screw M12 x 35 mm
8	4	100 332 005	Star washer M12
9	4	121 140 024	
10	1	121 140 172	Bearing housing
11	1	100 421 000	Grease nipple M6
12	1	121 140 171	Spacer
13	1	100 323 344	
14	1	100 401 042	Ball bearing # 6310 Z C3
15	1	100 323 343	
16	1	121 140 019	Oil dip ring
17	4	100 321 010	Crosshead screw M5 x 12 mm
18	4	100 332 001	Star washer M5
19	1	121 140 017	Cover
20	1	121 150 243	
21	1	121 140 176	
22	1	121 150 231	Shaft
23	1	100 405 007	Key 14 x 9 x 60 mm
24	5	100 405 013	Key 8 x 7 x 50 mm
25	4	121 150 237	Spacer
26	1	121 150 238	Spacer
27	2	100 323 144	Disc washer
28	1	121 130 226	Spacer
29	1	100 407 025	Star washer MB 8
30	1	100 323 064	Ring nut KM 8
Cpl:	1	121 150 008	Bearing housing complete. Incl. items 1 - 30

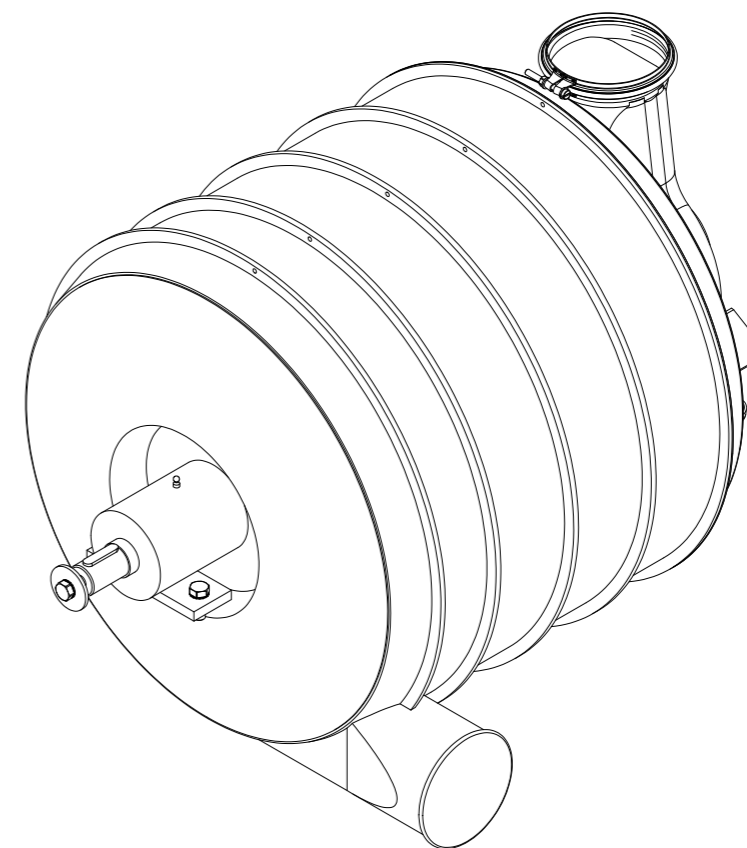
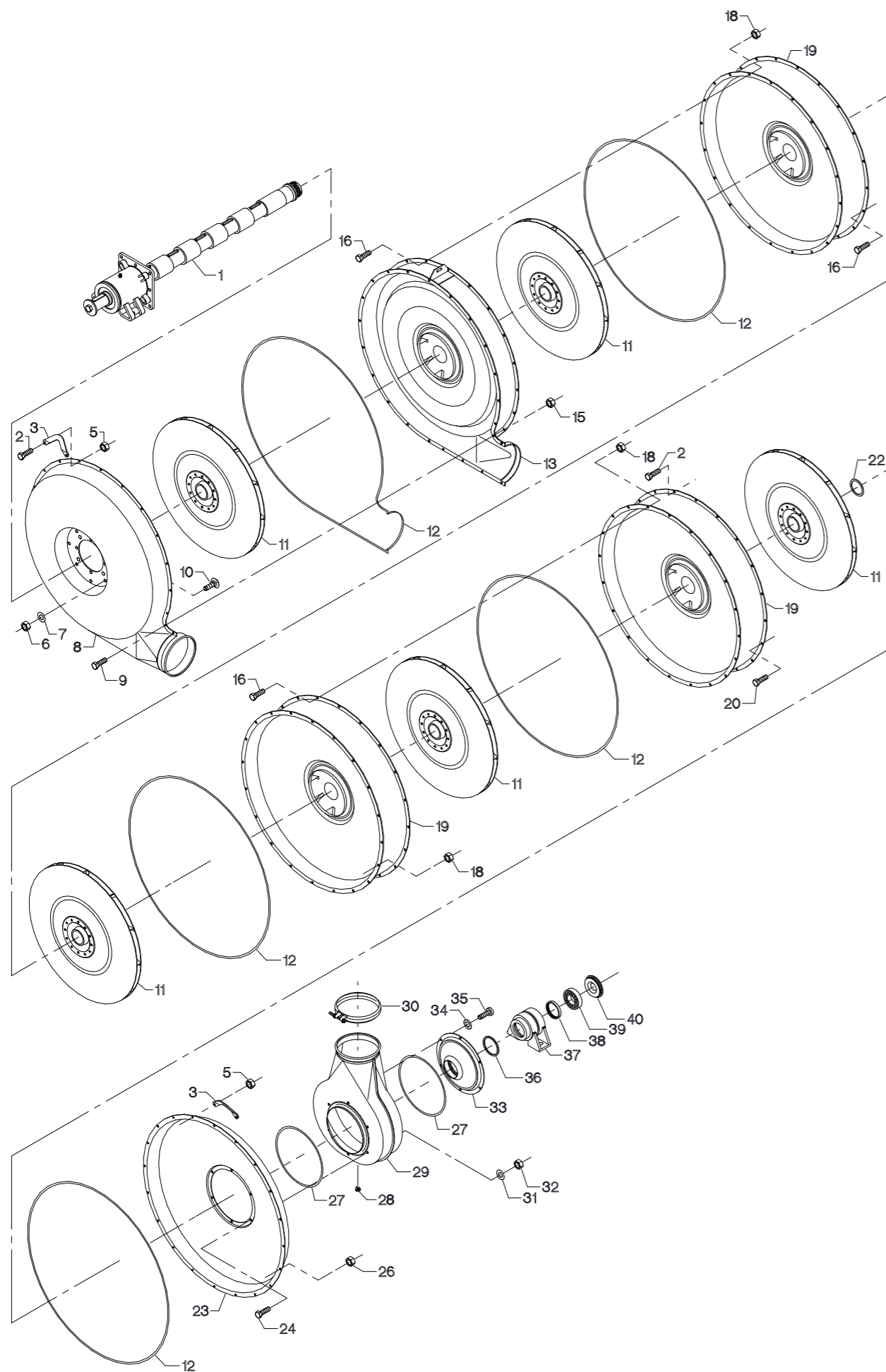

l	Pieces	Part no.	Notes
1	1	121 150 008	Bearing housing complete
2	4	100 306 001	Set screw M6 x 20 mm
3	2	121 150 257	Handle
5	4	100 316 075	Flange Nut M6 DIN 6923
6	8	100 316 003	Lock nut M8
7	8	100 331 005	Flat washer M8
8	1	121 140 111	
9	21	100 323 041	Set screw M6 x 16 mm
10	8	100 311 017	Coach bolt M8 x 25 mm
11	5	121 150 166	Rotor
12	-	121 100 303	Sealing strip. Indicate length 13 m w hen ordering
13	1	121 120 385	
15	21	100 316 075	Flange Nut M6 DIN 6923
16	60	100 323 041	Set screw M6 x 16 mm
18	60	100 316 075	Flange Nut M6 DIN 6923
19	3	121 130 253	
20	18	100 323 041	Set screw M6 x 16 mm
22	-	121 150 182	Flat washer
23	1	121 165 051	Cover
24	6	100 306 001	Set screw M6 x 20 mm
26	18	100 316 075	Flange Nut M6 DIN 6923
27	-	100 203 030	Sealing strip 2x6 mm. Indicate length 1.6 m w hen ordering
28	1	121 130 131	Valve
29	1	121 130 255	Air intake
30	1	122 000 857	Clamp with screw OK160
31	6	100 331 004	Flat washer M6
32	6	100 316 002	Lock nut M6
33	1	121 130 257	
34	6	100 332 002	Star washer M6
35	6	100 321 013	Crosshead screw M6 x 10 mm
36	1	100 413 066	O-ring
37	1	121 134 376	Bearing housing
38	1	121 150 243	Sealing ring
39	1	100 401 072	Ball bearing # 6208 - 2RS
40	1	121 130 042	Bearing cover
Cpl:	1	121 165 050	Blower section complete including packing. Incl. items 1-40

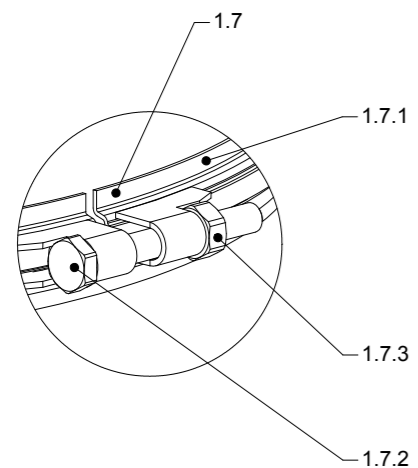

DETAIL A (2 : 5)

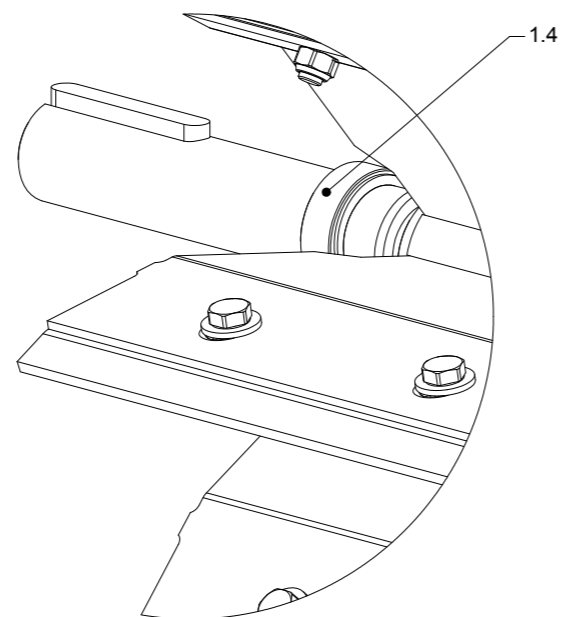

DETAIL D (2 : 5)

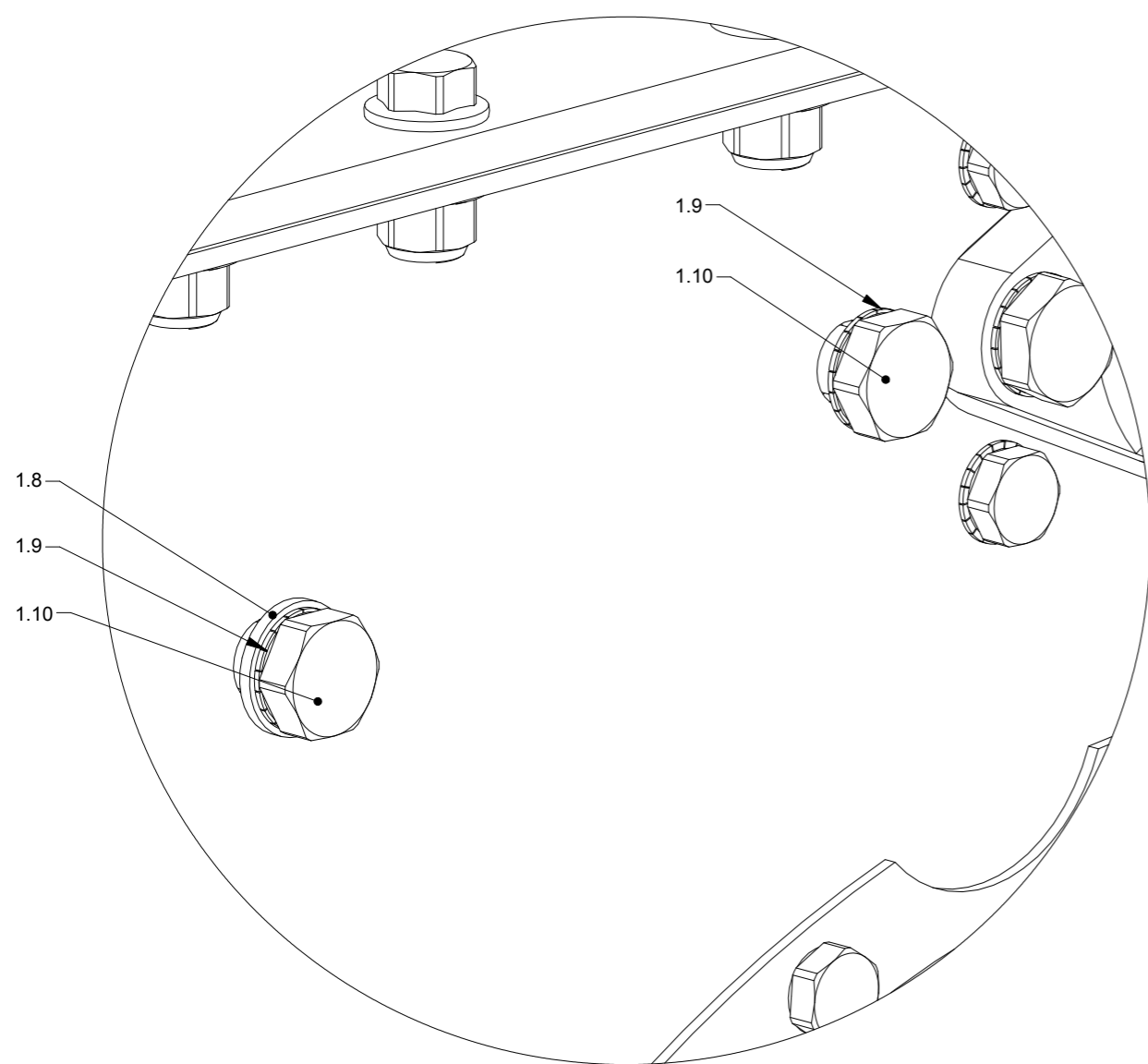
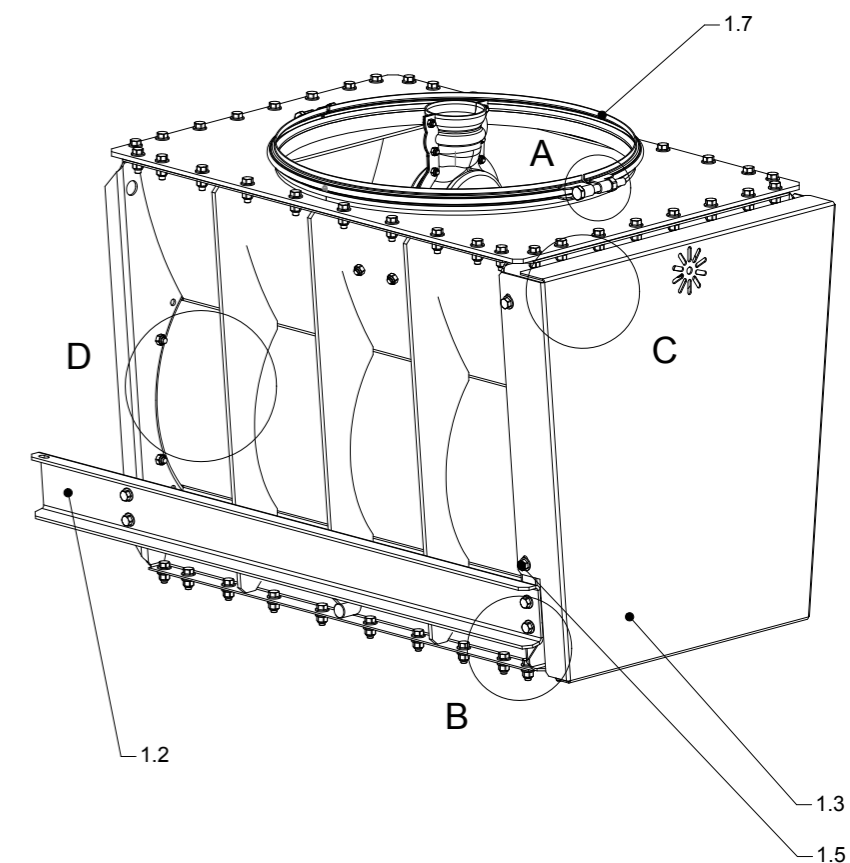

DETAIL C (1 : 1)

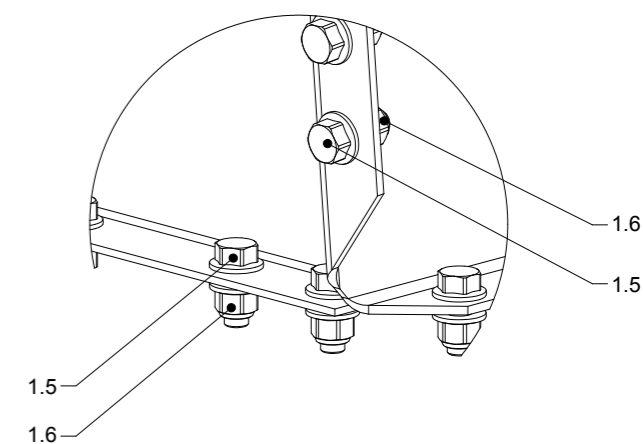

DETAIL B (2 : 5)

Pos.	Pieces	Part no.	Notes
1.2	1	121165360	
1.3	1	121165361	
1.4	1	121165474	
1.5	38	100323380	M8x20 DIN 6921
1.6	24	100316093	M8 DIN 6926
1.7	1	121165455	
1.7.1	2	121165373	
1.7.2	2	100308019	M10x80 DIN 933
1.7.3	2	100315021	M10 DIN 934
1.8	1	100331006	Washer M10
1.9	2	100332004	DIN 6798A M10
1.10	2	100306029	M10x25 DIN 933

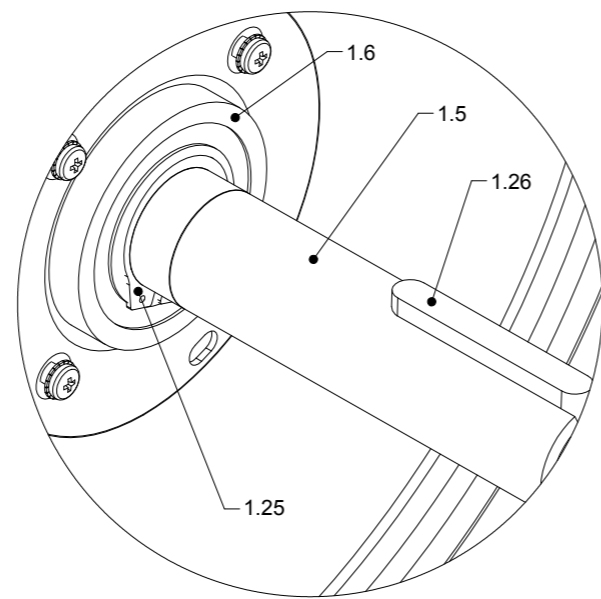
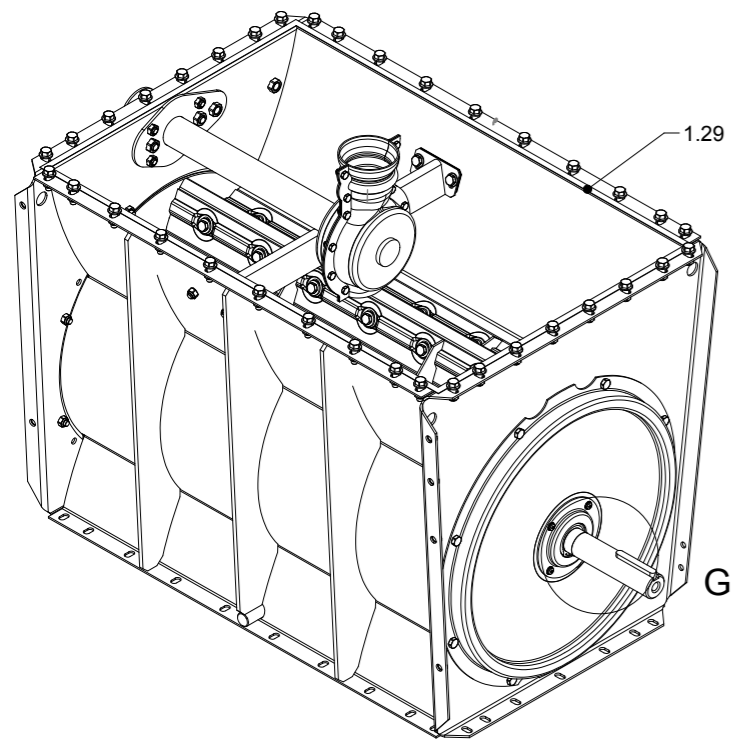

DETAIL G (1 : 2)

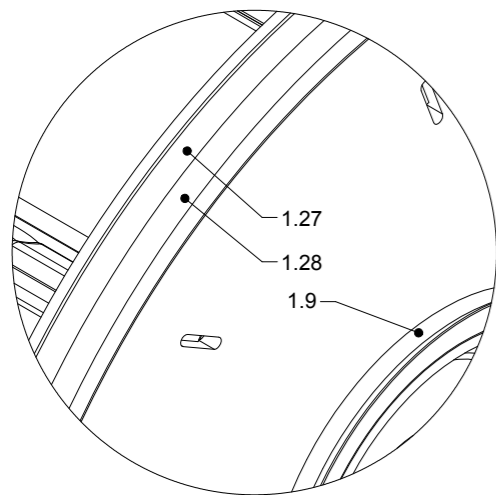
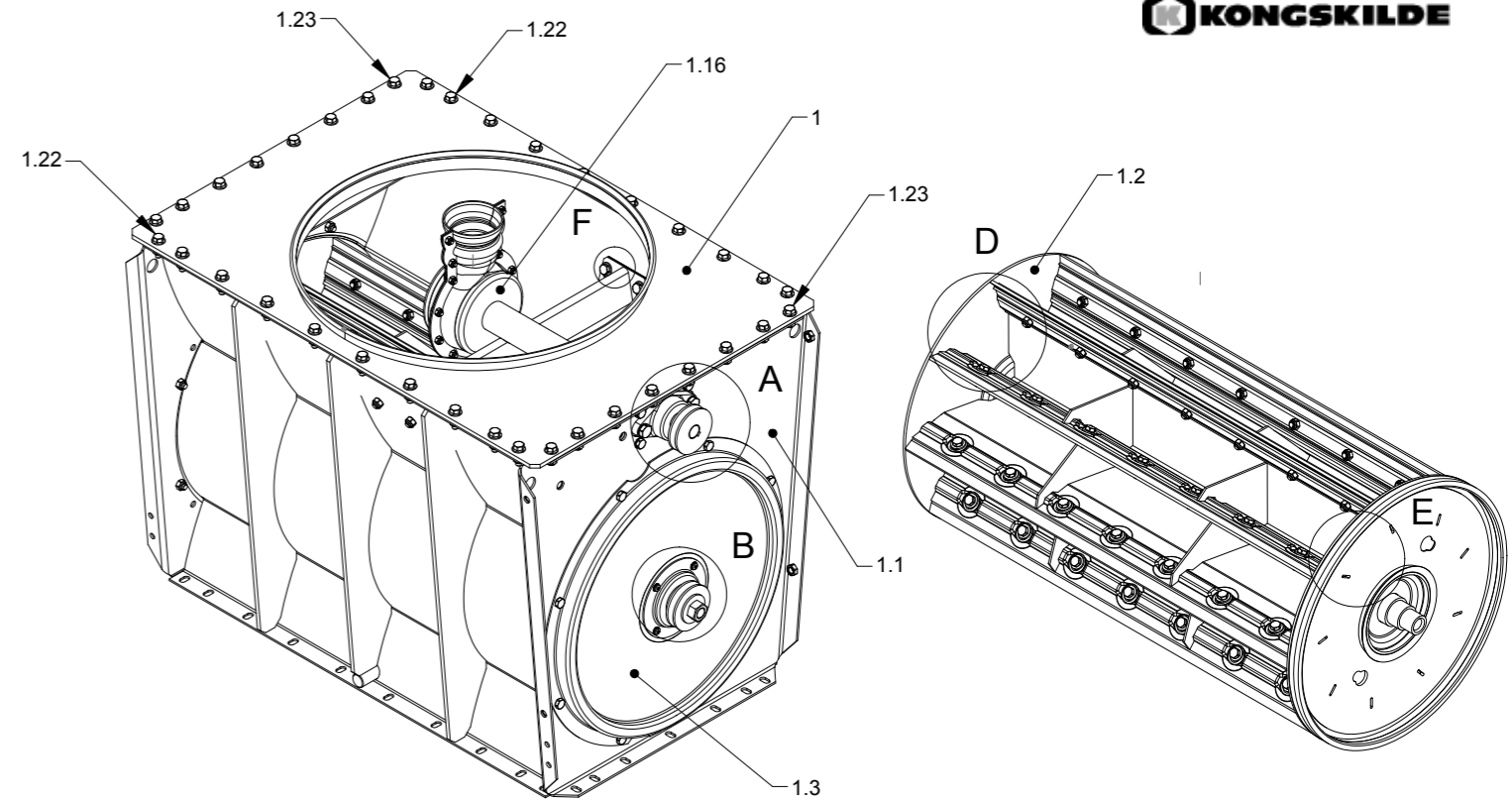

DETAIL E (1 : 2)

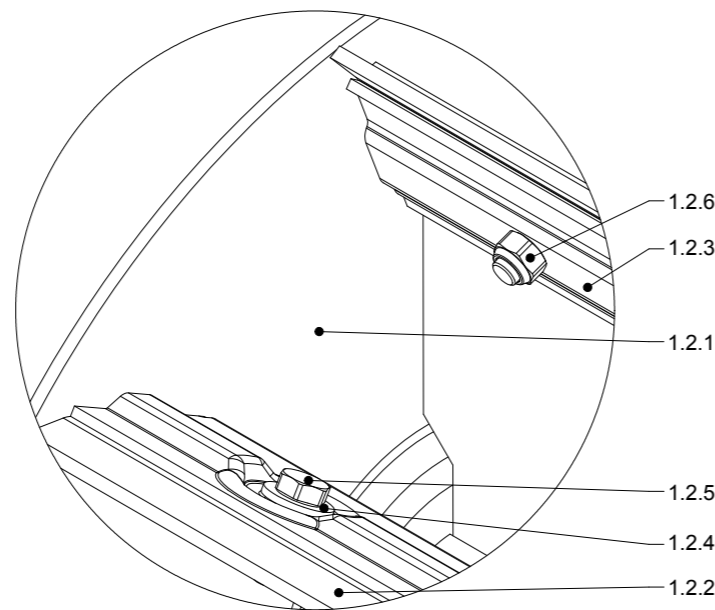

DETAIL D (1 : 2)

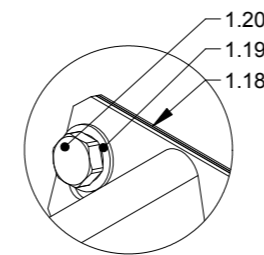

DETAIL F (1 : 2)

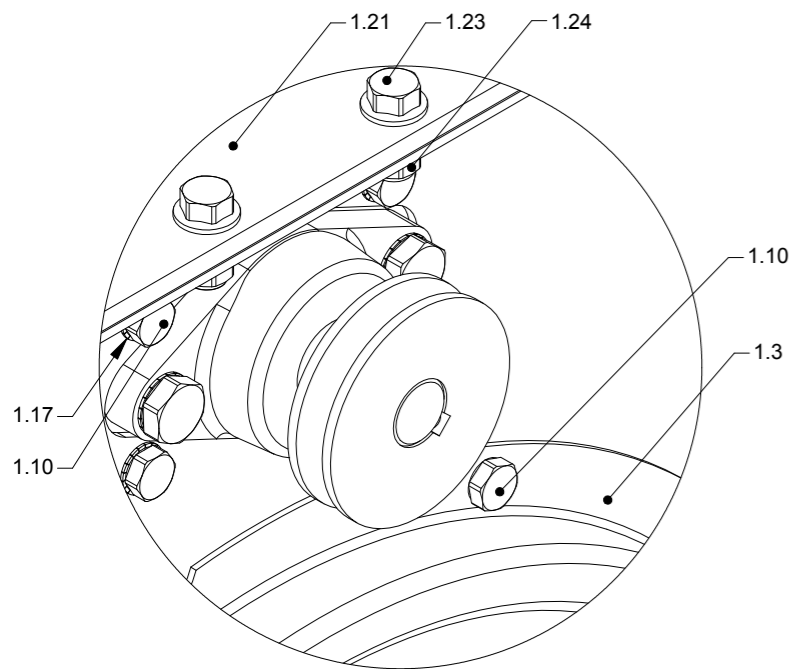

DETAIL A (1 : 2)

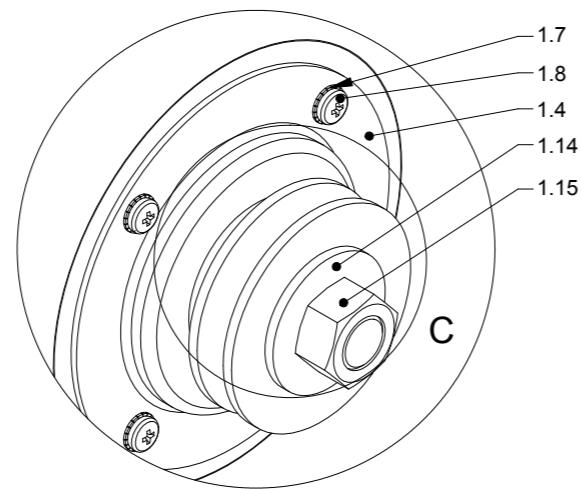

DETAIL B (1 : 2)

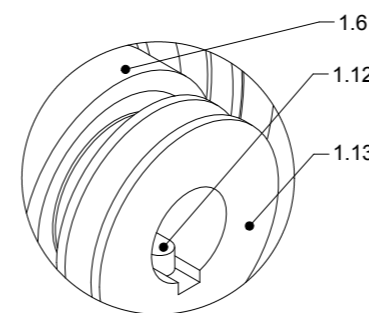

DETAIL C (1 : 2)

Pos.	Pieces	Part no.	Notes
1	1	121165329	CA75 Cpl.
1.1	1	121165310	
1.2	1	121165328	
1.2.1	1	121165321	
1.2.2	9	121165322	
1.2.3	9	121165323	
1.2.4	63	100331014	Washer 5/16"
1.2.5	63	100308049	M8x25 DIN 933 10,9
1.2.6	63	100316003	M8 DIN 985-6
1.3	2	121109088	
1.4	2	121109089	
1.5	1	121165316	
1.6	2	100401003	6307 2RS1
1.7	8	100332002	DIN 6798A M6
1.8	8	100321013	Krydskæringskrue M6x10
1.9	2	100413069	
1.10	20	100306014	M8x16 DIN 933
1.11	16	100316003	M8 DIN 985-6
1.12	1	100405008	KEY A8x7x16 DIN 6885
1.13	1	121165402	
1.14	1	121108135	
1.15	1	121165357	
1.16	1	121165338	Cpl.
1.17	4	100332003	DIN 6798A M8
1.18	4	121165359	
1.19	4	100331005	Washer 5/16"
1.20	4	100304012	M8x20 DIN 933
1.21	1	121165324	
1.22	20	100323381	M8x25 DIN 6921
1.23	16	100323380	M8x20 DIN 6921
1.24	36	100316093	M8 DIN 6926
1.25	1	100407011	
1.26	1	100405035	KEY A10x8x70 DIN 6885
1.27	2	121100368	
1.28	2	121100349	
1.29	1	100202011	Order 2.7m

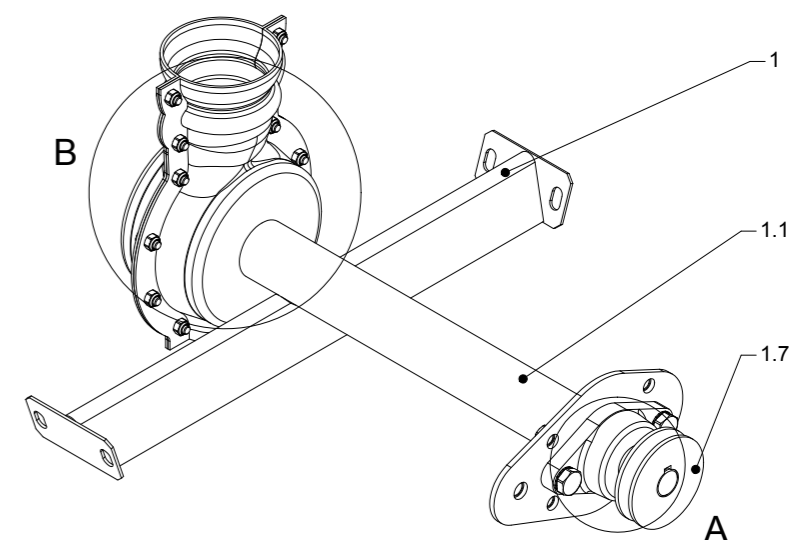
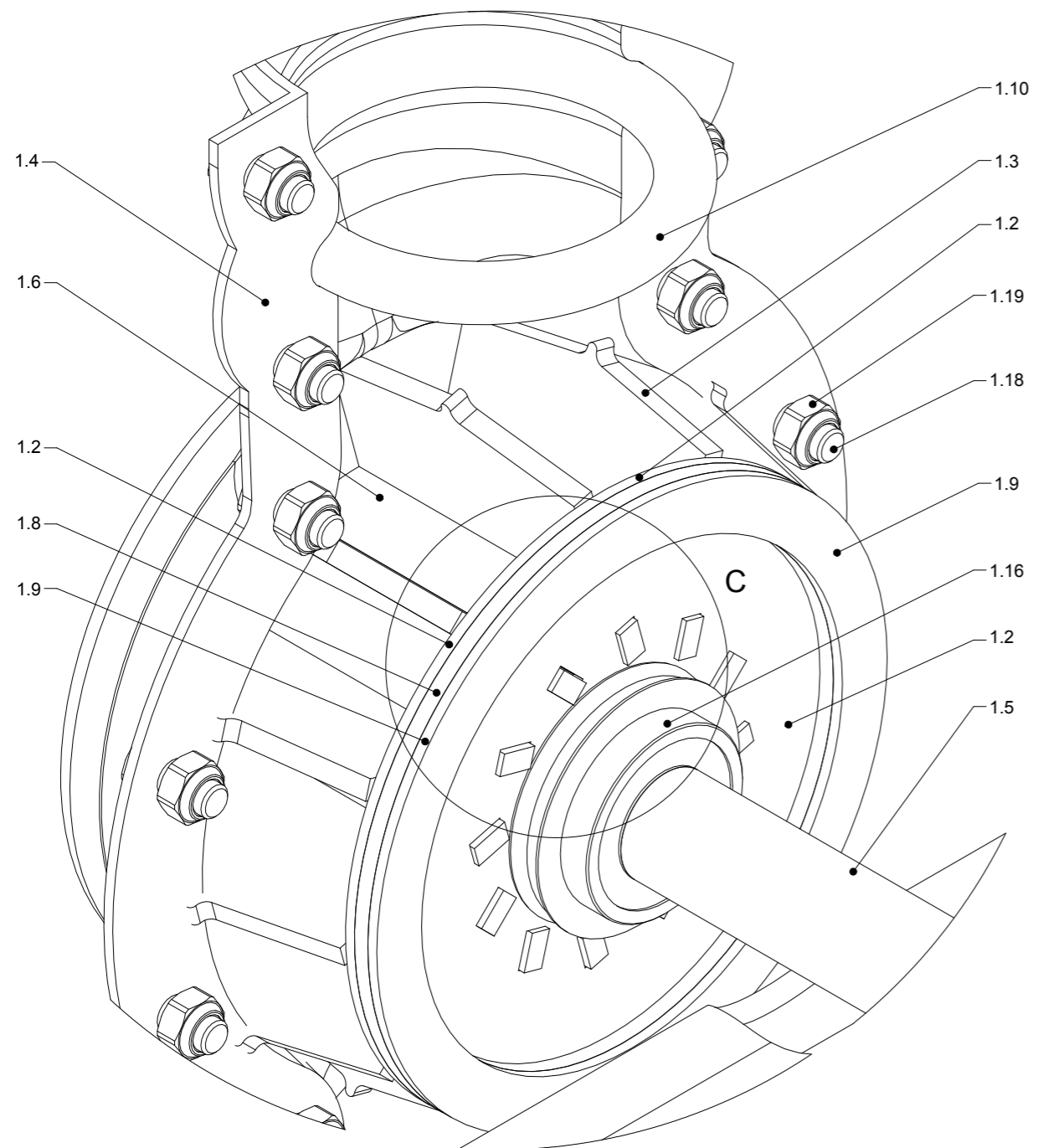

DETAIL B (1 : 1)

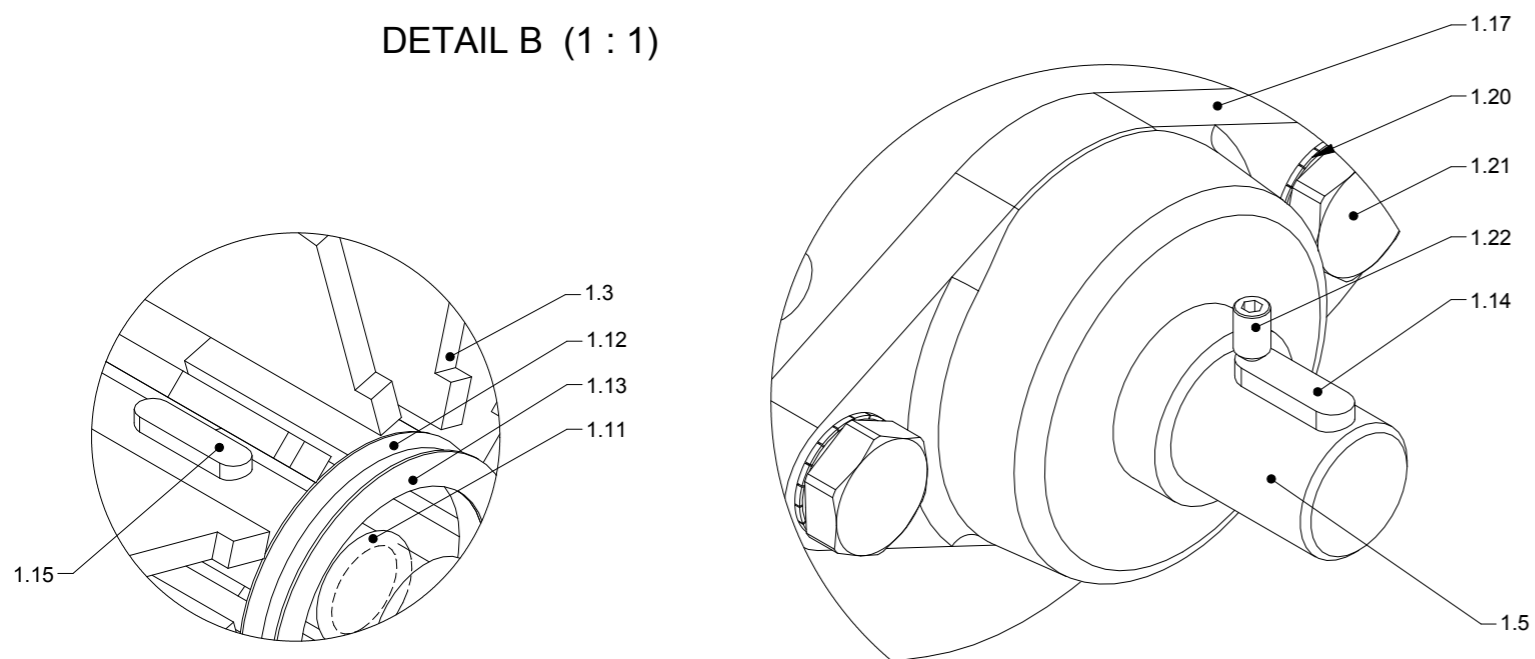

Pos.	Pieces	Part no.	Notes
1	1	121165338	Cpl.
1.1	1	121165333	
1.2	2	121165336	
1.3	12	121165337	
1.4	1	121165331	
1.5	1	121165339	
1.6	1	121165335	
1.7	1	121165344	
1.8	2	121165341	
1.9	2	121165342	
1.10	1	121165343	
1.11	2	100413173	
1.12	2	100413174	
1.13	2	100331090	
1.14	1	100405025	KEY A6x6x20 DIN 6885
1.15	1	100405021	KEY A5x5x20 DIN 6885
1.16	2	100401055	6202 2RS1
1.17	1	100401088	
1.18	12	100308018	M6x12 DIN 933
1.19	12	100316002	M6 DIN 985-6
1.20	2	100332004	DIN 6798A M10
1.21	2	100306029	M10x25 DIN 933
1.22	1	100322018	M5x8 DIN 916

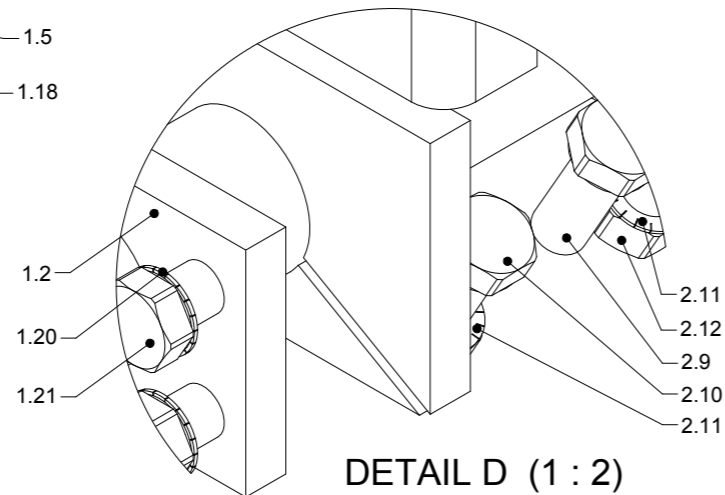
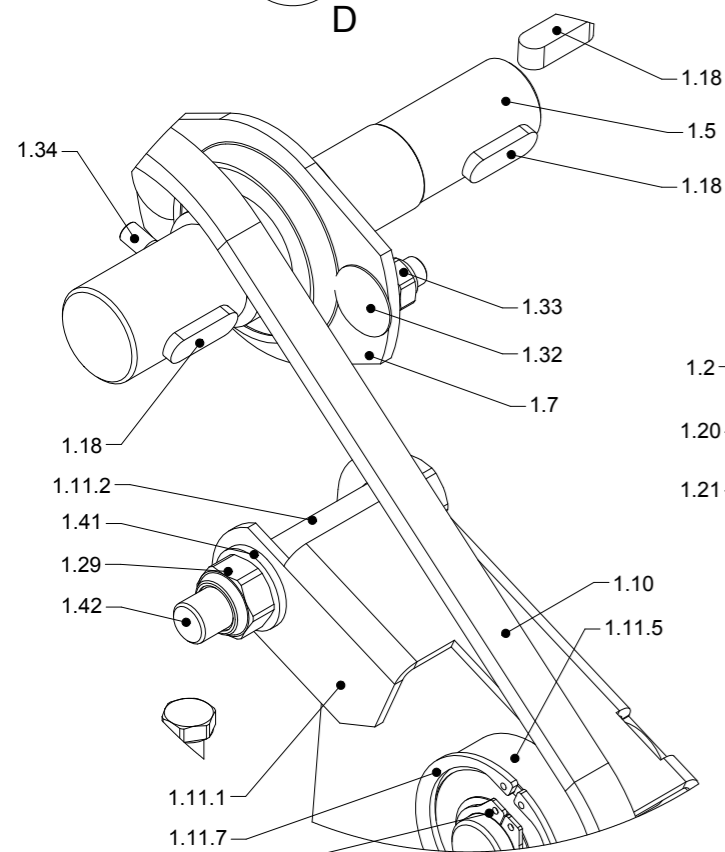
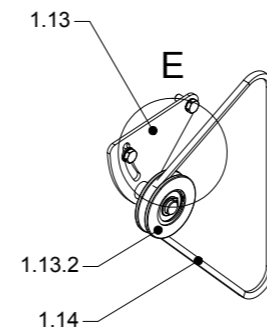
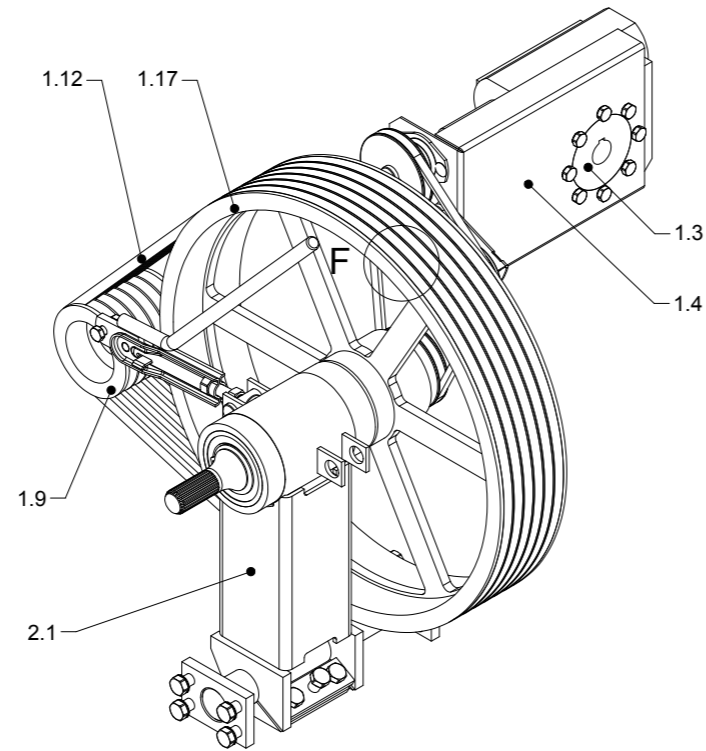
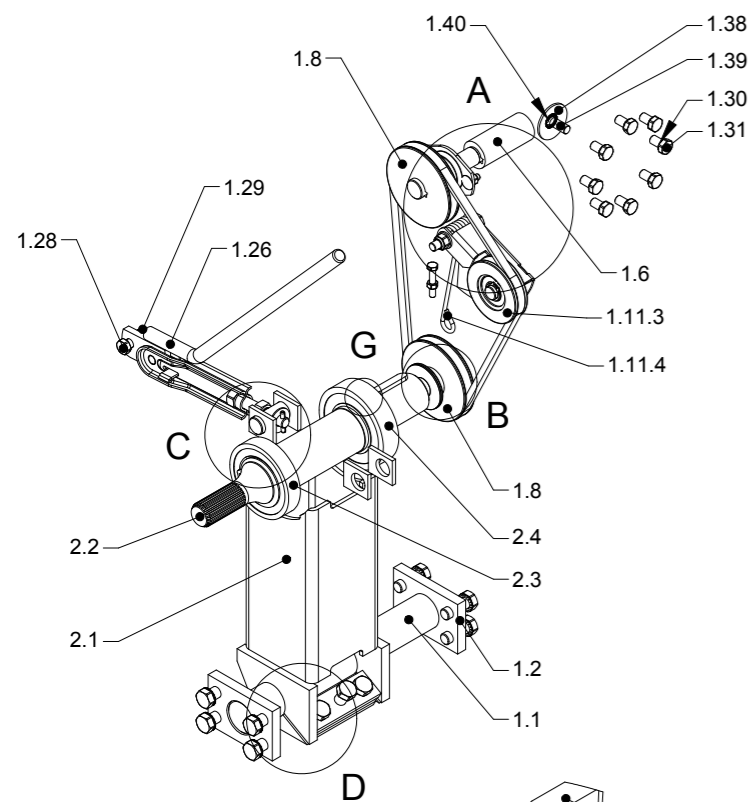

DETAIL D (1 : 2)

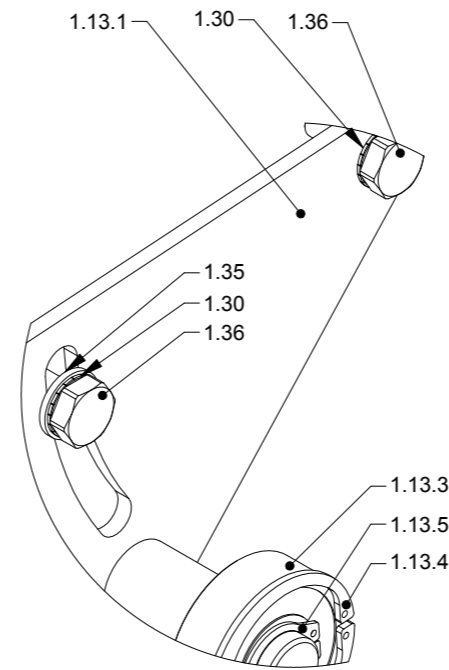

DETAIL E (1 : 2)

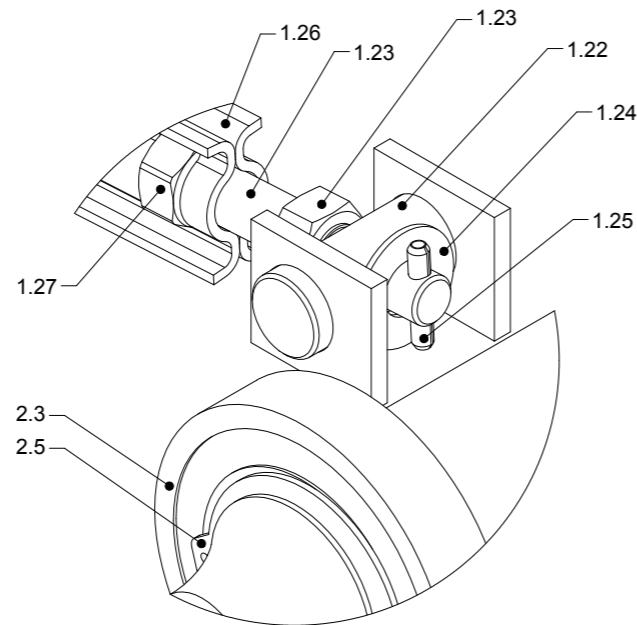

DETAIL C (1 : 2)

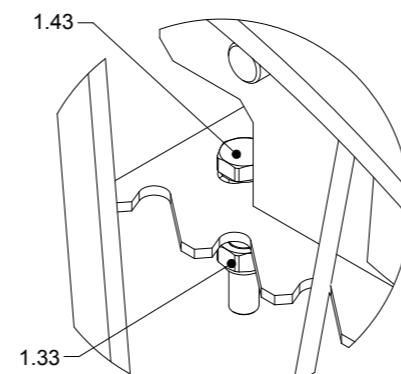

DETAIL F (1 : 2)

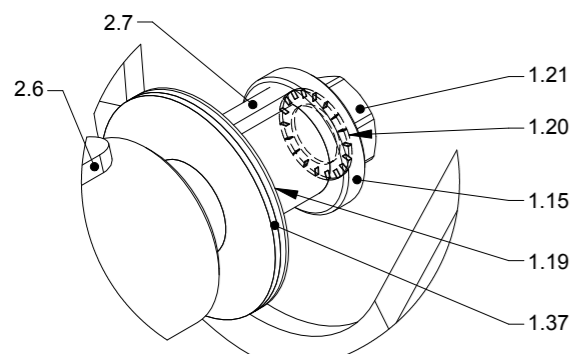

DETAIL B (1 : 2)

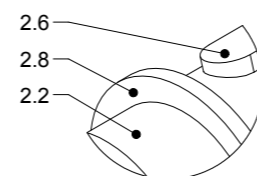

DETAIL G (1 : 2)

Pos.	Pieces	Part no.	Notes
1.1	1	121165251	
1.2	2	121165252	
1.3	1	100505095	
1.4	1	121165260	
1.5	1	121165261	
1.6	1	121165265	
1.7	1	100401039	
1.8	2	121165253	
1.9	1	121165270	
1.10	1	100403247	
1.11.1	1	121165267	
1.11.2	1	121165273	
1.11.3	1	121165268	
1.11.4	1	121165272	
1.11.5	1	100401006	6304 2RS
1.11.6	1	100407011	
1.11.7	1	100407019	
1.12	11	100403248	
1.13	1	121165243	
1.13.1	1	121165242	
1.13.2	1	121165268	
1.13.3	1	100401006	6304 2RS
1.13.4	1	100407019	
1.13.5	1	100407011	
1.14	1	100403090	
1.15	1	121165227	
1.17	1	121165254	
1.18	3	100405023	
1.19	1	121165257	
1.20	9	100332006	DIN 6798A M16
1.21	9	100306055	M16x40 DIN 933
1.22	1	121131285	
1.23	1	121131129	
1.24	1	100331008	Washer 5/8"
1.25	1	100333018	Slottet spring pin Ø6 x 32 DIN1481
1.26	1	121131115	
1.27	1	100315020	M16 DIN 934
1.28	1	100306044	M12x40 DIN 933
1.29	2	100316005	M12 DIN 985-6
1.30	10	100332004	DIN 6798A M10
1.31	8	100304030	M12x20 DIN 933
1.32	2	100311016	M8x20 DIN 603
1.33	3	100316003	M8 DIN 985-6
1.34	1	100322001	M6x10 DIN 916
1.35	1	100331006	Washer M10
1.36	2	100306029	M10x25 DIN 933
1.37	2	121165491	
1.38	1	121000071	
1.39	1	100306043	M12x30 DIN 933
1.40	1	100332005	DIN 6798A M12
1.41	1	100331007	Washer M12
1.42	1	100306178	M12x80 DIN931
1.43	1	100306020	M8x45 DIN 931
2.1	1	121150013	
2.2	1	121140178	
2.3	1	100401013	6212 2RS1
2.4	1	100401041	6311 2RS1
2.5	1	100407015	U60x2 DIN 471
2.6	1	100405010	
2.7	1	100405015	
2.8	1	121131288	
2.9	1	100306055	M16x40 DIN 933
2.10	2	100306056	M16x45 DIN 933
2.11	2	100332006	DIN 6798A M16
2.12	2	100315020	M16 DIN 934

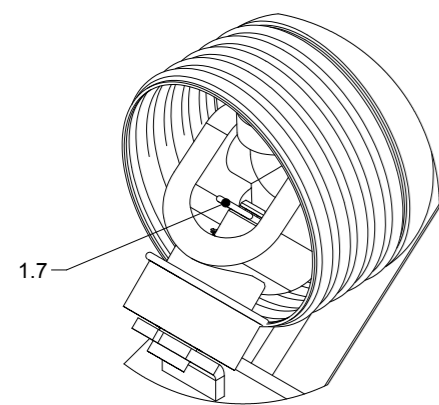
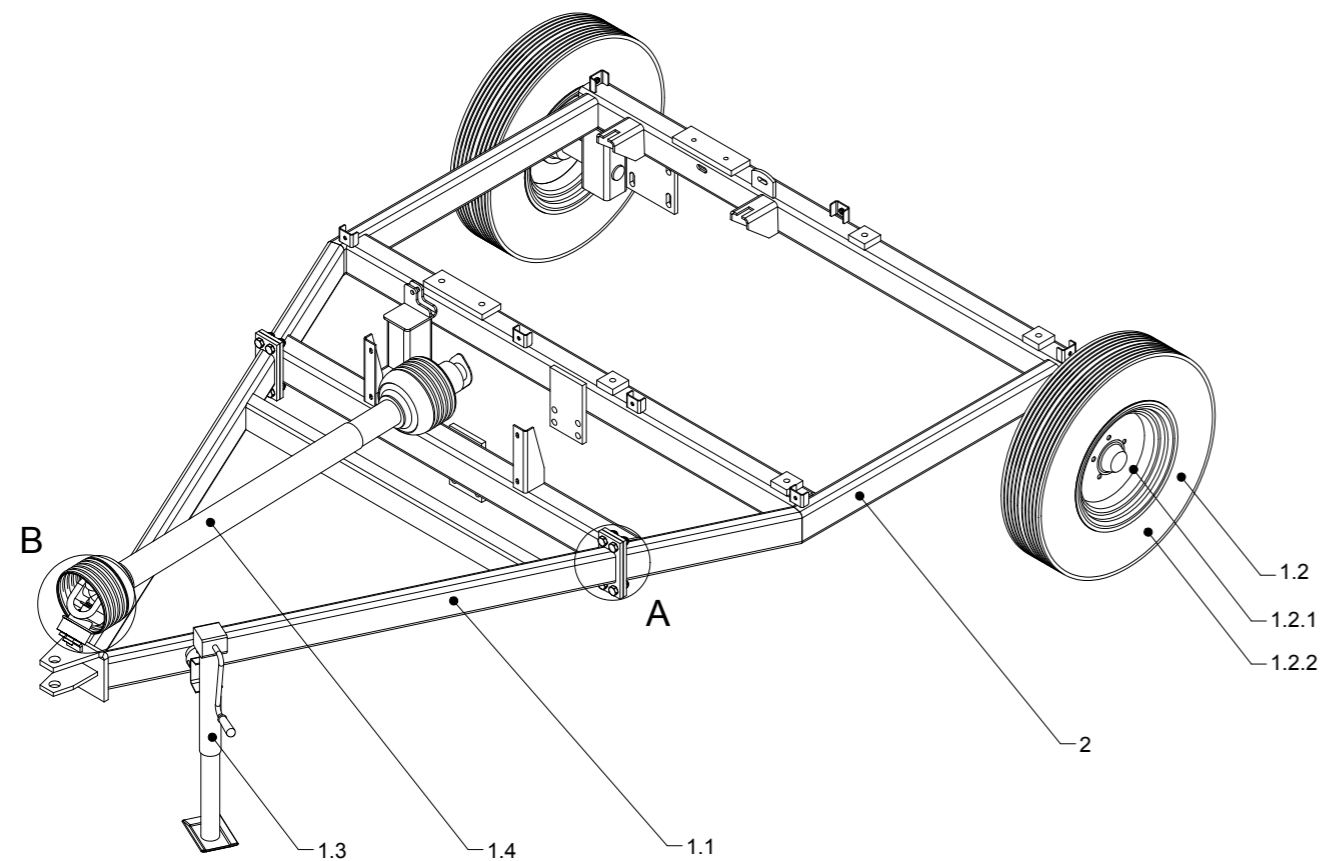

DETAIL B (1 : 5)

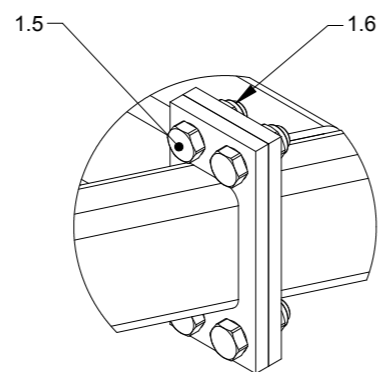

DETAIL A (1 : 5)

Pos.	Pieces	Part no.	Notes
1.1	1	121165170	
1.2	2	121000782	Rim 5,5kx14-5/102/140 & Tyre 205-75 R14C 6PR kpl
1.2.1	1	100423057	Rim 5,5kx14-5/102/140
1.2.2	1	100423096	Tyre 205-75 R14C 6PR
1.3	1	121134128	
1.4	1	199073340	
1.5	8	100306056	M16x45 DIN 933
1.6	8	100316006	M16 DIN 985-6
1.7	1	100333011	Hair pin clip ø4mm
2	1	121165021	

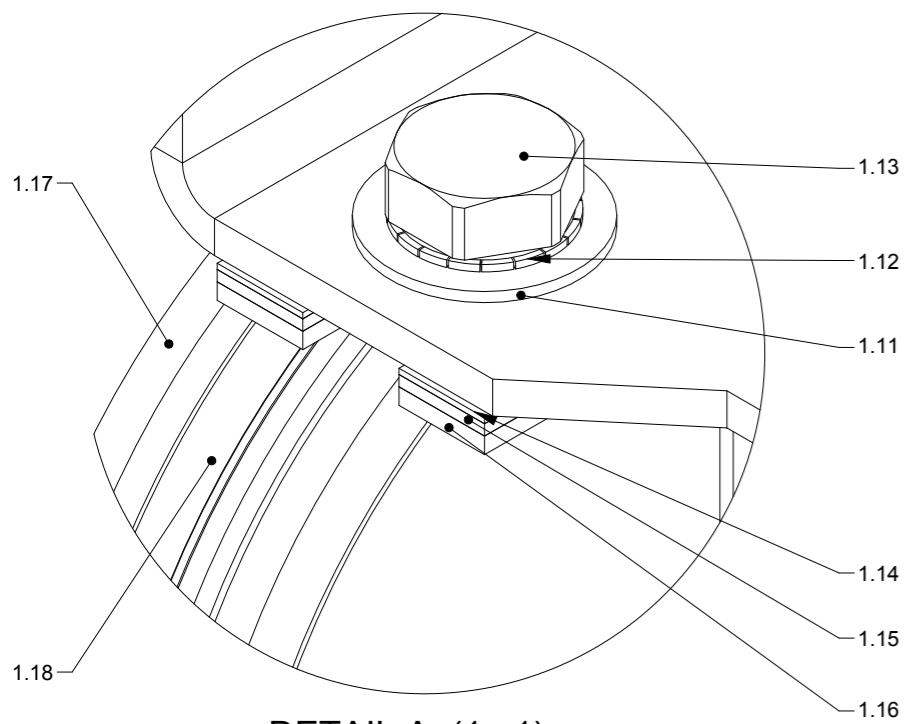

DETAIL A (1 : 1)

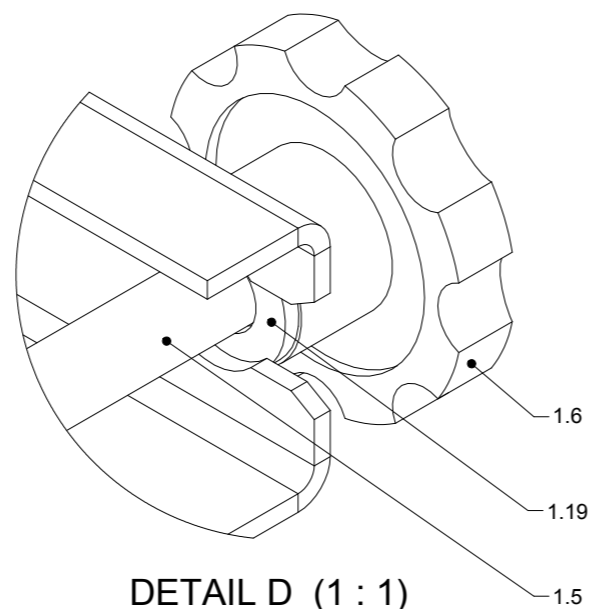

DETAIL D (1 : 1)

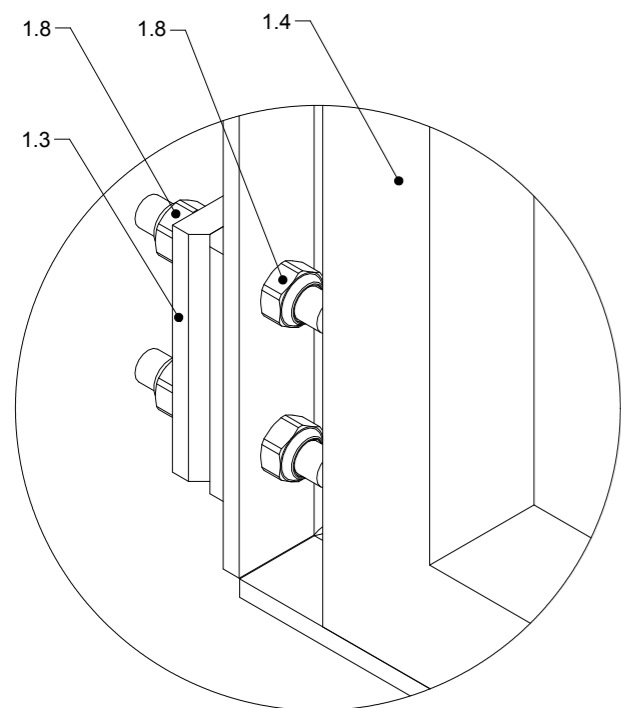
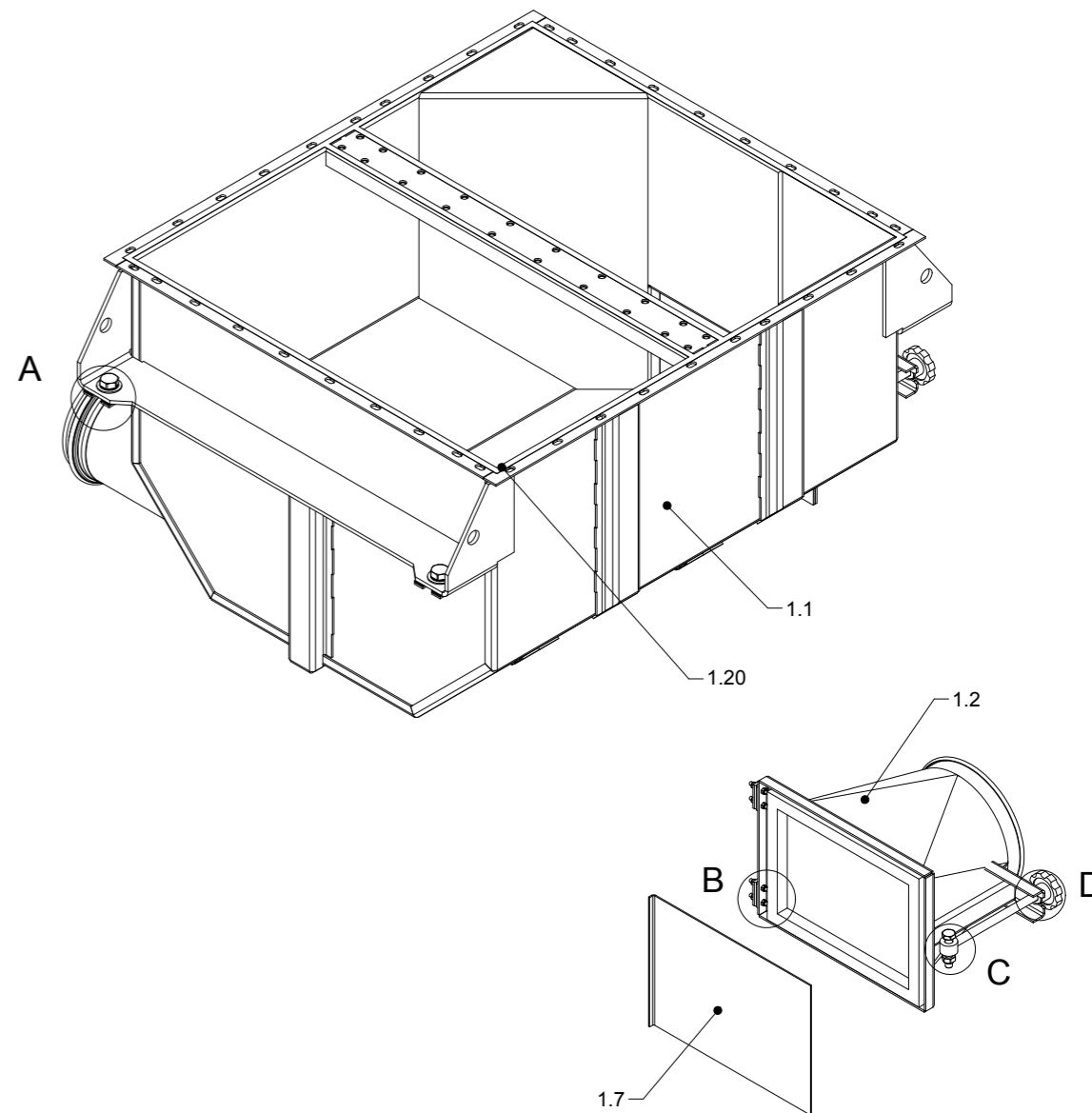

DETAIL B (1 : 1)

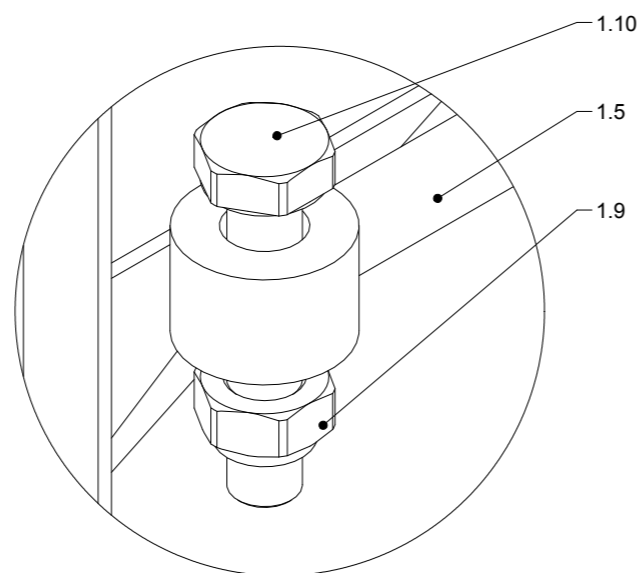

DETAIL C (1 : 1)

Pos.	Pieces	Part no.	Notes
1.1	1	121165203	
1.2	1	121165195	
1.3	2	100323339	
1.4	1	121165205	
1.5	1	100323376	
1.6	1	100414063	Star handle M12
1.7	1	121165197	
1.8	8	100316063	M5 DIN 985-6
1.9	1	100316004	M10 DIN 985-6
1.10	1	100304027	M10x50 DIN 933
1.11	4	100331008	Washer 5/8"
1.12	4	100332006	DIN 6798A M16
1.13	4	100304044	M16x30 DIN 933
1.14	4	121165206	Spacer 1 mm
1.15	4	121165207	Spacer 2 mm
1.16	2	121165492	Spacer 3 mm
1.17	1	110101079	
1.18	1	122000857	Clamp with bolt OK160
1.19	1	100331000	Washer M12
1.20	1	100202024	5 x 10 mm. Order 4.5 m

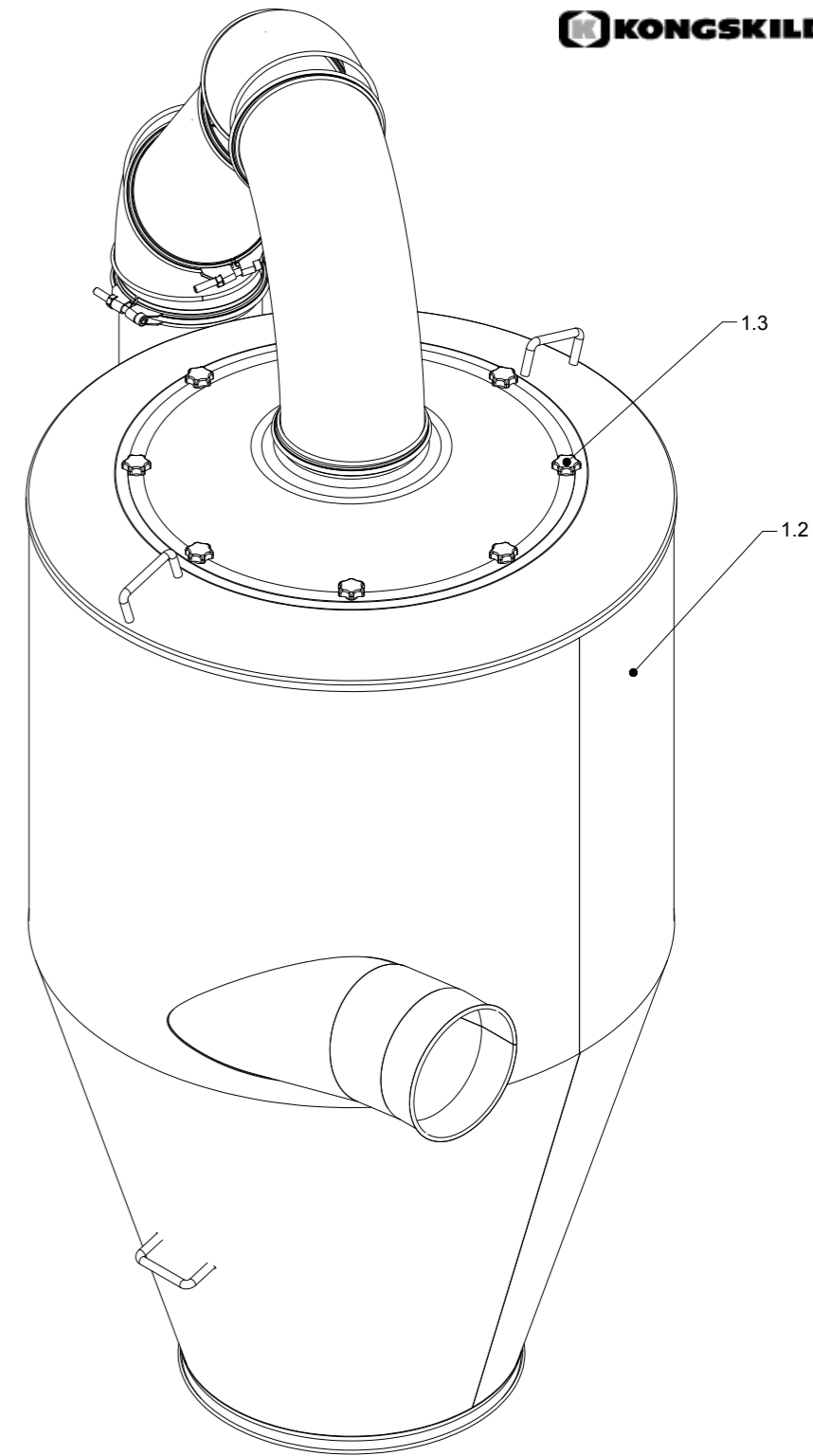
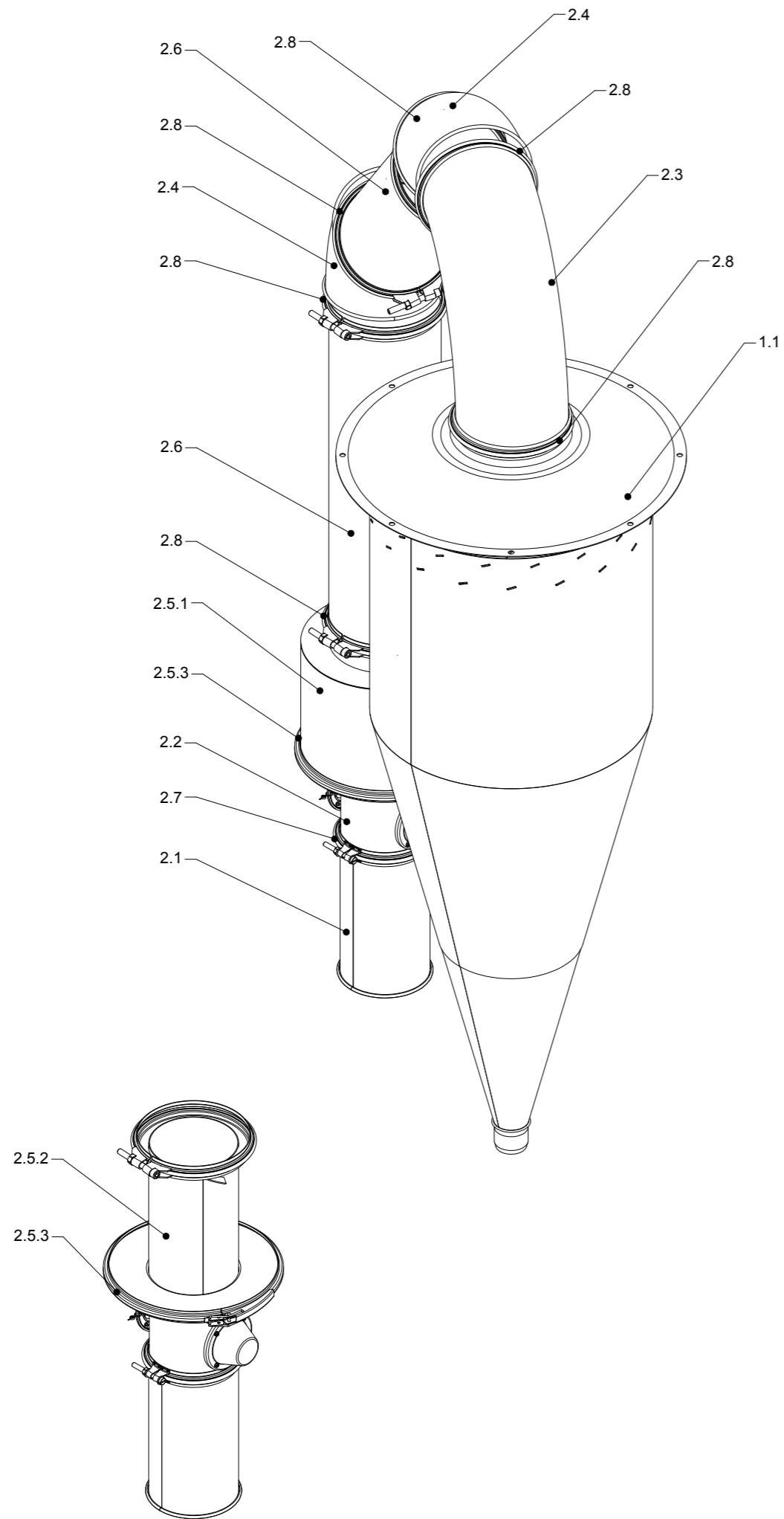

Pos.	Pieces	Part no.	Notes
1.1	1	121165380	
1.2	1	121165393	
1.3	8	100414050	
2.1	1	121150270	
2.2	1	121165350	
2.3	1	121165369	
2.4	2	121165376	
2.5	1	121165480	
2.5.1	1	121165481	
2.5.2	1	121165482	
2.5.3	1	9251681012	
2.6	2	121165495	
2.7	2	122000857	Clamp with bolt OK160
2.8	6	122050206	Clamp with bolt OK160, reinforced

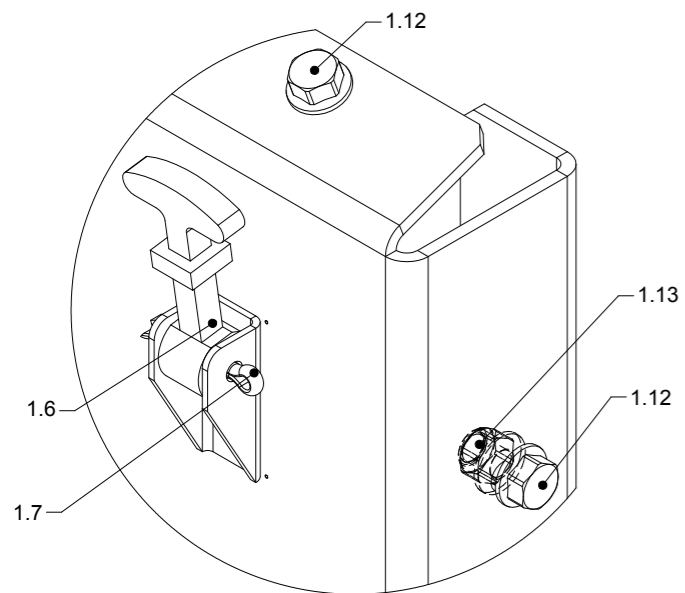
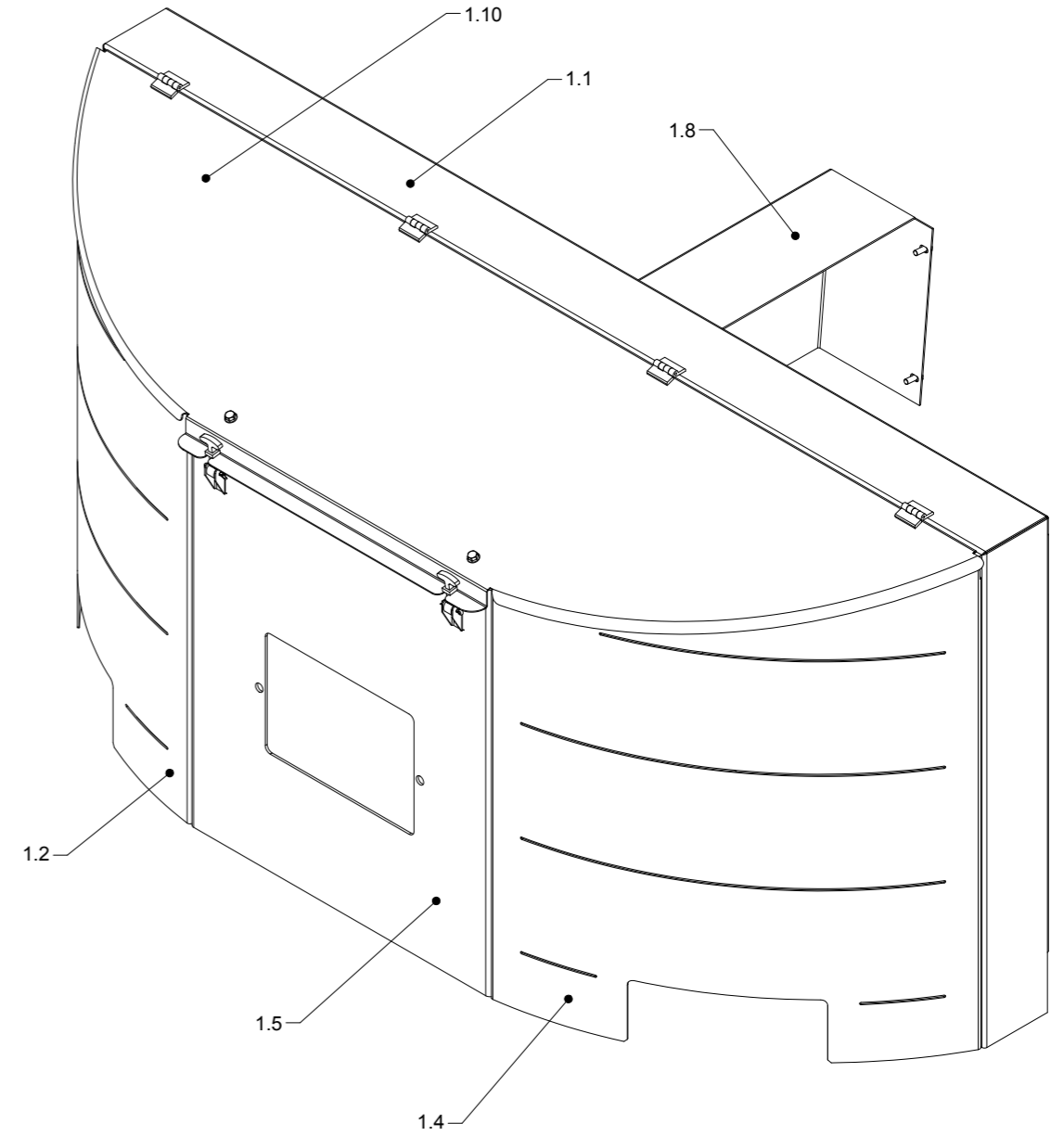
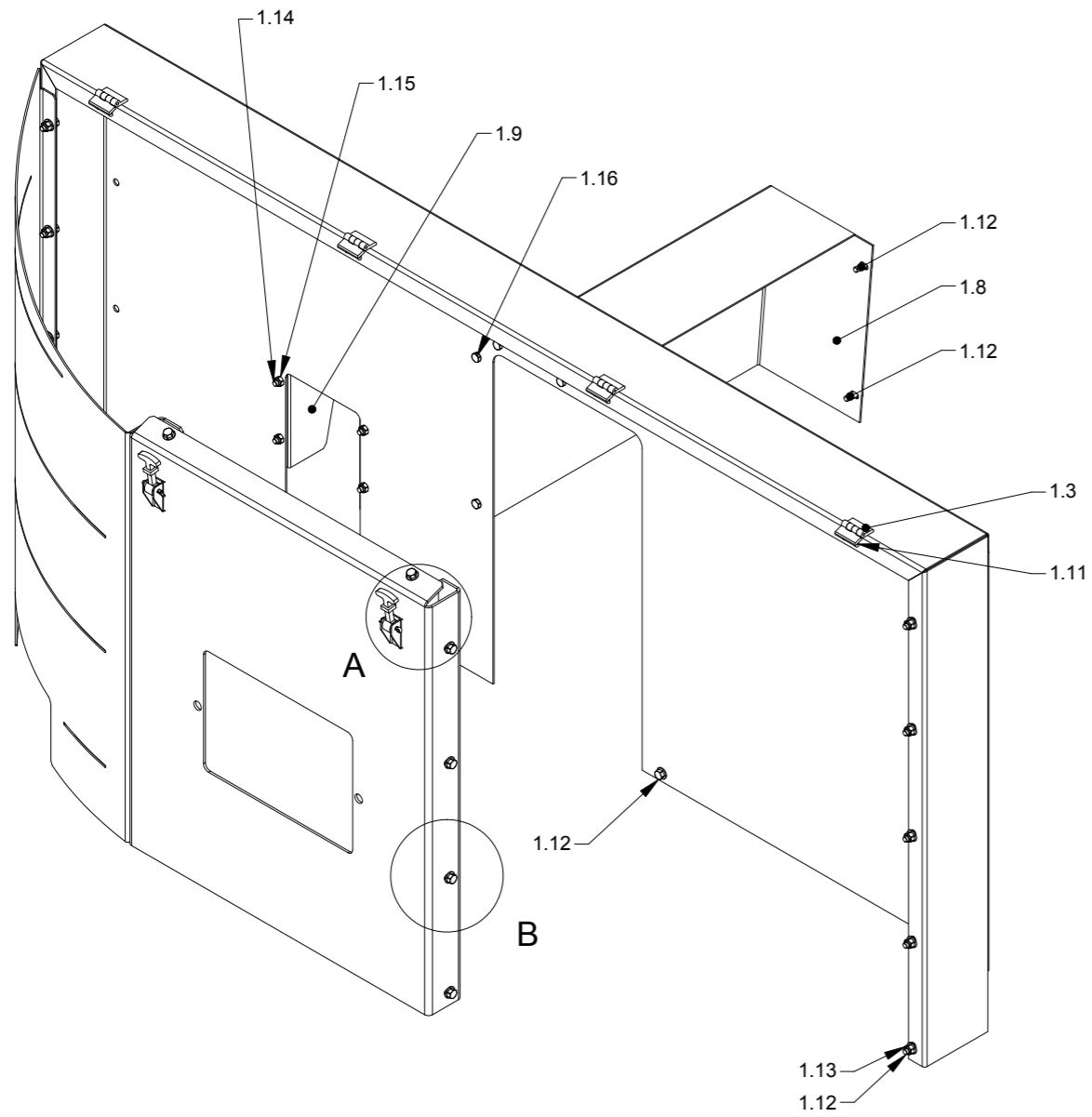

DETAIL A (1 : 2)

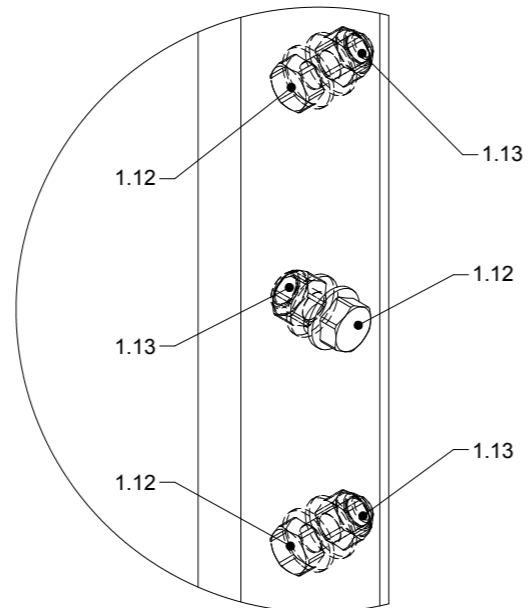

DETAIL B (1 : 2)

Pos.	Pieces	Part no.	Notes
1.1	1	121165210	
1.2	1	121165212	
1.3	4	100323339	
1.4	1	121165215	
1.5	1	121165226	
1.6	2	121131191	
1.7	2	100333004	Split pin Ø5x30 mm
1.8	1	121165230	
1.9	1	121165232	
1.10	1	121165218	
1.11	16	100316063	M5 DIN 985-6
1.12	30	100323380	M8x20 DIN 6921
1.13	22	100316093	M8 DIN 6926
1.14	4	100306014	M8x16 DIN 933
1.15	4	100316003	M8 DIN 985-6
1.16	4	100308029	M8x12 DIN 933

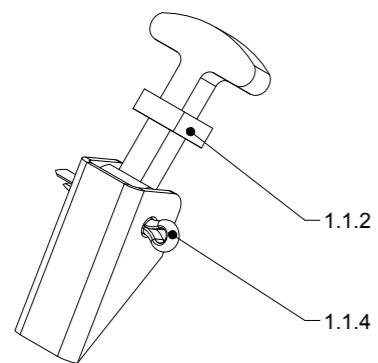

DETAIL A (1 : 2)

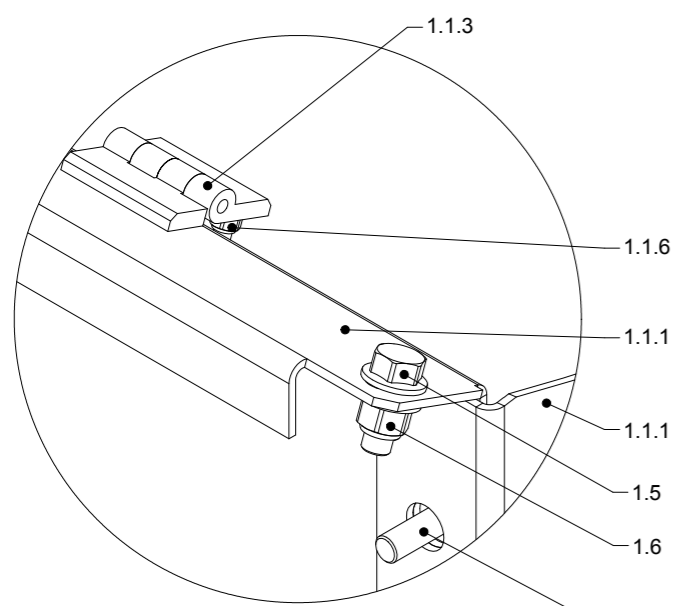

DETAIL B (1 : 2)

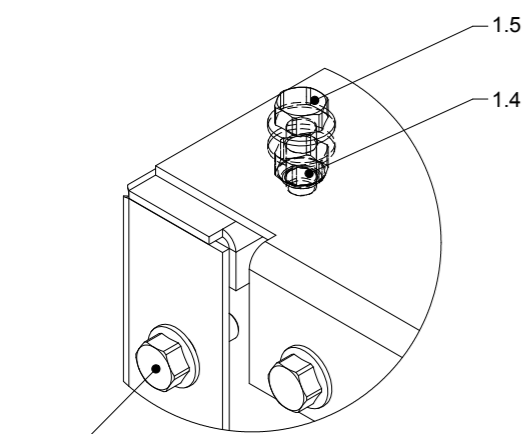

DETAIL C (1 : 2)

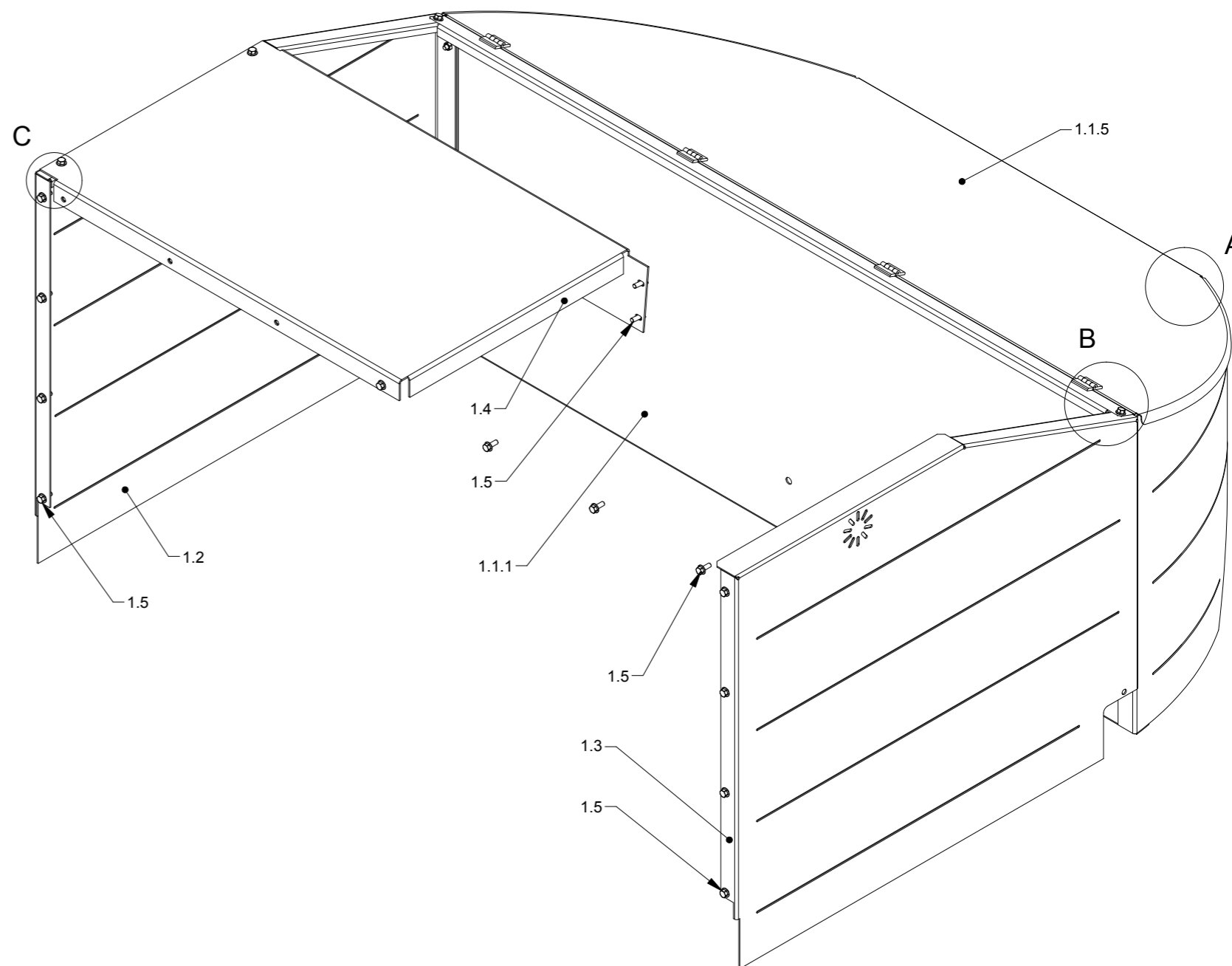

?

Pos.	Pieces	Part no.	Notes
1.1.1	1	121165220	
1.1.2	2	121131191	
1.1.3	4	100323339	
1.1.4	2	100333004	Split pin Ø5x30 mm
1.1.5	1	121165225	
1.1.6	16	100316063	M5 DIN 985-6
1.2	1	121165217	
1.3	1	121165219	
1.4	1	121165229	
1.5	24	100323380	M8x20 DIN 6921
1.6	4	100316093	M8 DIN 6926

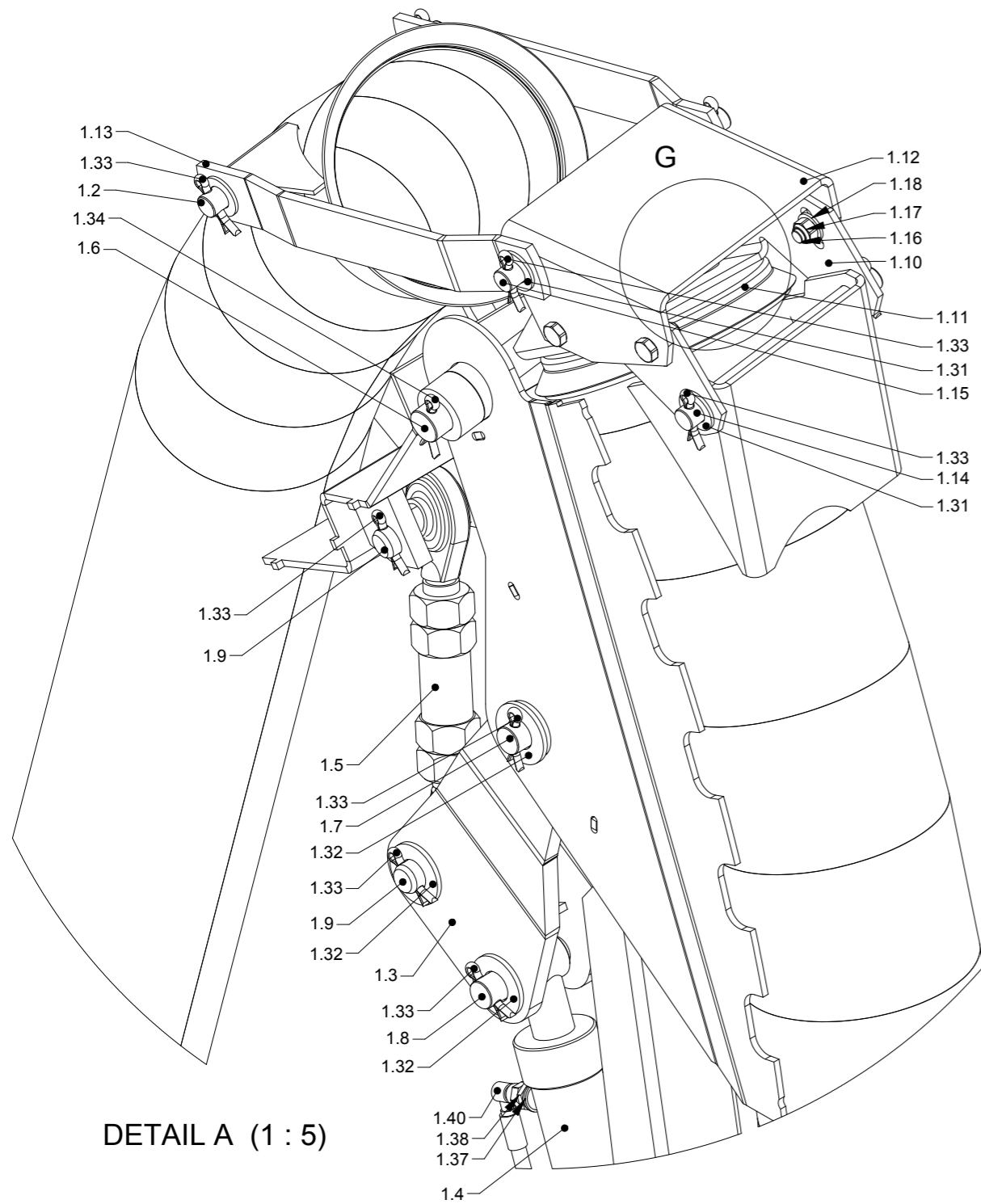

DETAIL A (1 : 5)

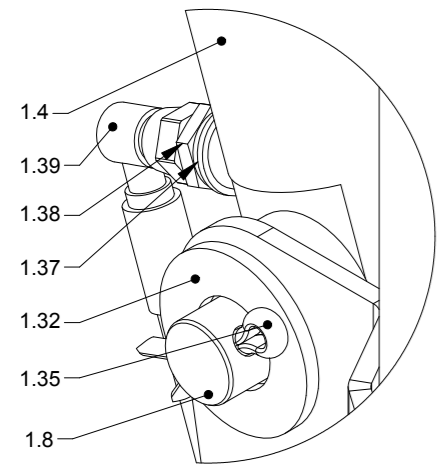

DETAIL B (1 : 2)

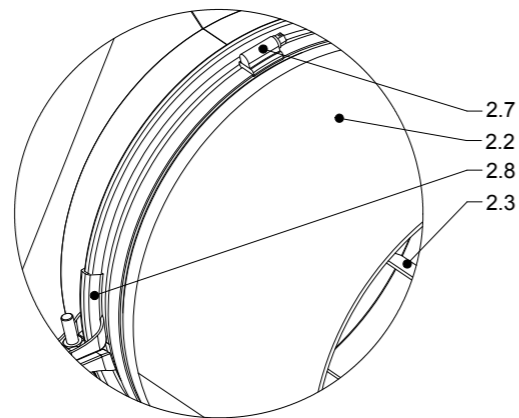

DETAIL C (1 : 5)

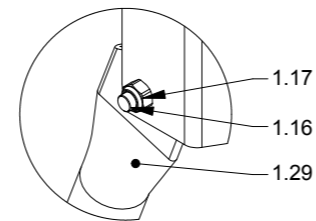

DETAIL H (1 : 5)

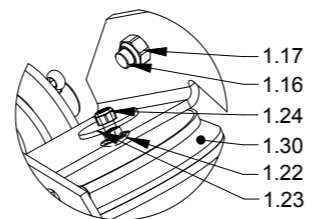

DETAIL G (1 : 5)

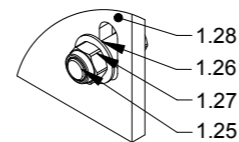

DETAIL E (1 : 5)

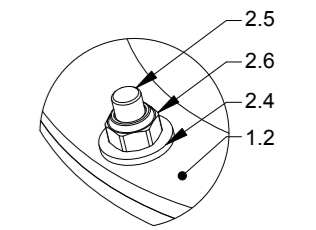
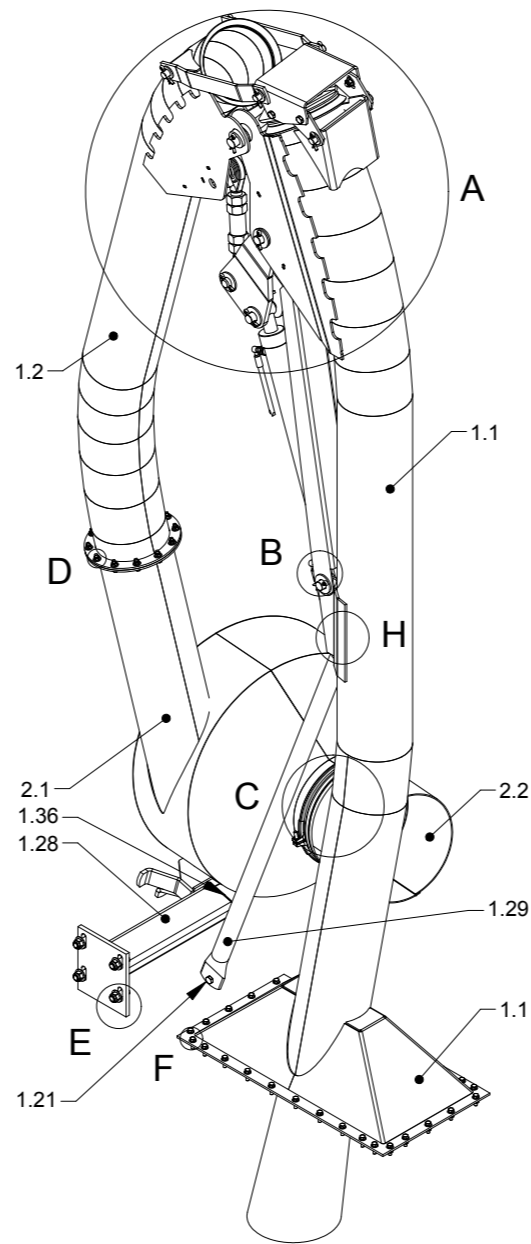

DETAIL D (1 : 2)

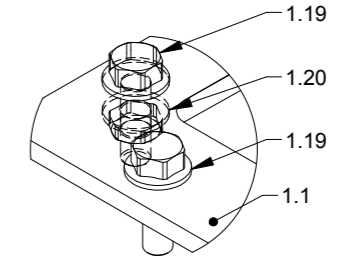

DETAIL F (1 : 2)

Pos.	Pieces	Part no.	Notes
1.1	1	121165055	
1.2	1	121165056	
1.3	1	121165105	
1.4	1	121165060	
1.5	1	121165058	
1.6	1	121165092	
1.7	1	121165122	
1.8	2	121165121	
1.9	2	121165115	
1.10	1	121165100	
1.11	1	121165099	
1.12	1	121165101	
1.13	2	121165102	
1.14	1	121165103	
1.15	1	121165104	
1.16	5	100306043	M12x30 DIN 933
1.17	6	100316005	M12 DIN 985-6
1.18	3	100331016	Washer 7/16"
1.19	30	100323381	M8x25 DIN 6921
1.20	20	100316091	M8 DIN 6923
1.21	1	100304033	M12x35 DIN 933
1.22	2	100311016	M8x20 DIN 603
1.23	2	121000021	
1.24	2	100316003	M8 DIN 985-6
1.25	4	100306056	M16x45 DIN 933
1.26	8	100331008	Washer 5/8"
1.27	4	100316006	M16 DIN 985-6
1.28	1	121165131	
1.29	1	121165117	
1.30	1	121165140	
1.31	6	100331009	Washer M20
1.32	8	100381018	Washer 1"
1.33	14	100333008	Split pin Ø8x40 mm
1.34	2	100333029	Split pin Ø8x50 mm
1.35	2	100333008	Split pin Ø8x40 mm
1.36	1	100414018	
1.37	2	100413152	
1.38	2	100420062	
1.39	1	121165136	
1.40	1	121165137	
2.1	1	121165057	
2.2	1	121165135	
2.3	1	121165134	
2.4	24	100331014	Washer 5/16"
2.5	12	100306017	M8x30 DIN 933
2.6	12	100316003	M8 DIN 985-6
2.7	1	100420177	
2.8	1	125500329	

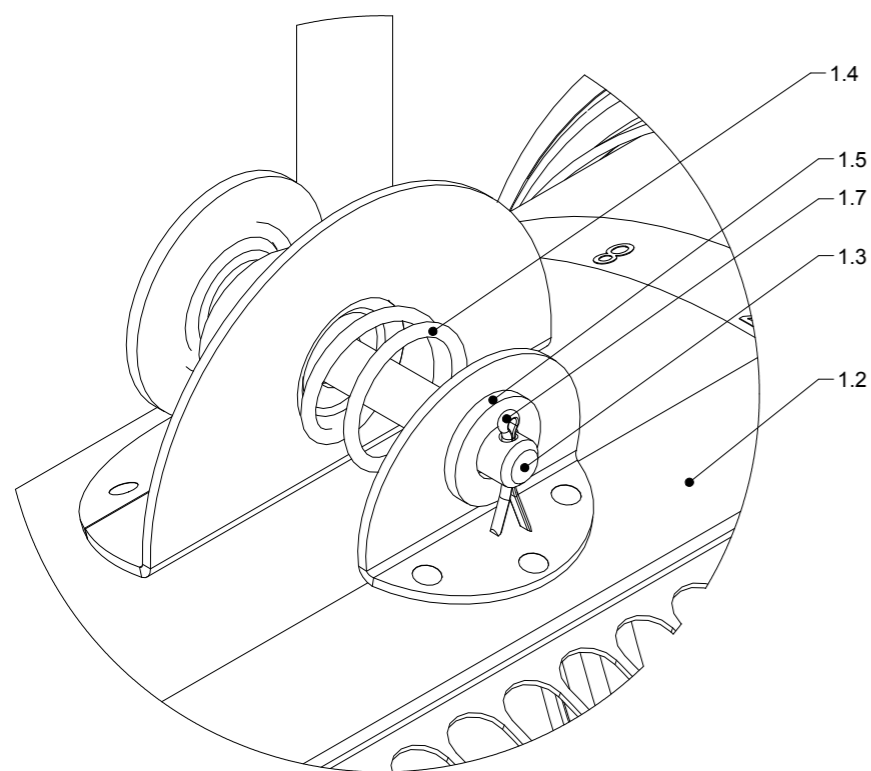

DETAIL A (1 : 1)

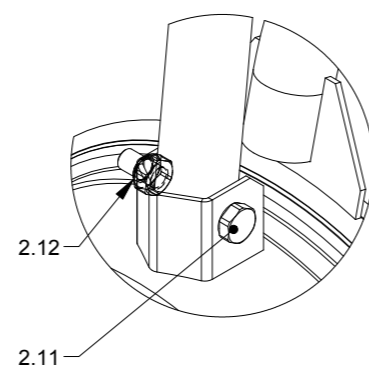

DETAIL C (1 : 2)

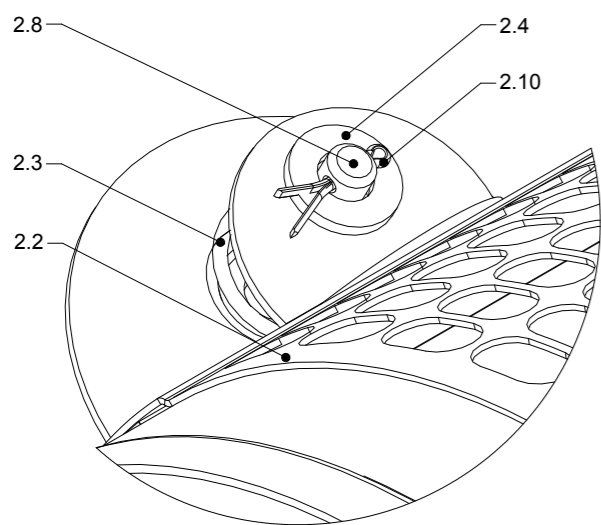

DETAIL B (1 : 1)

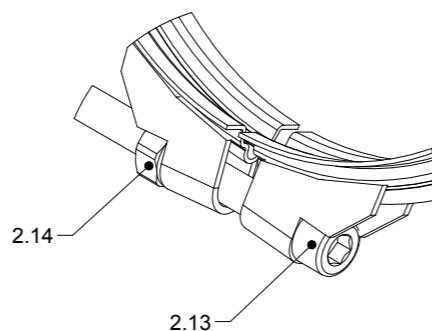

DETAIL D (1 : 2)

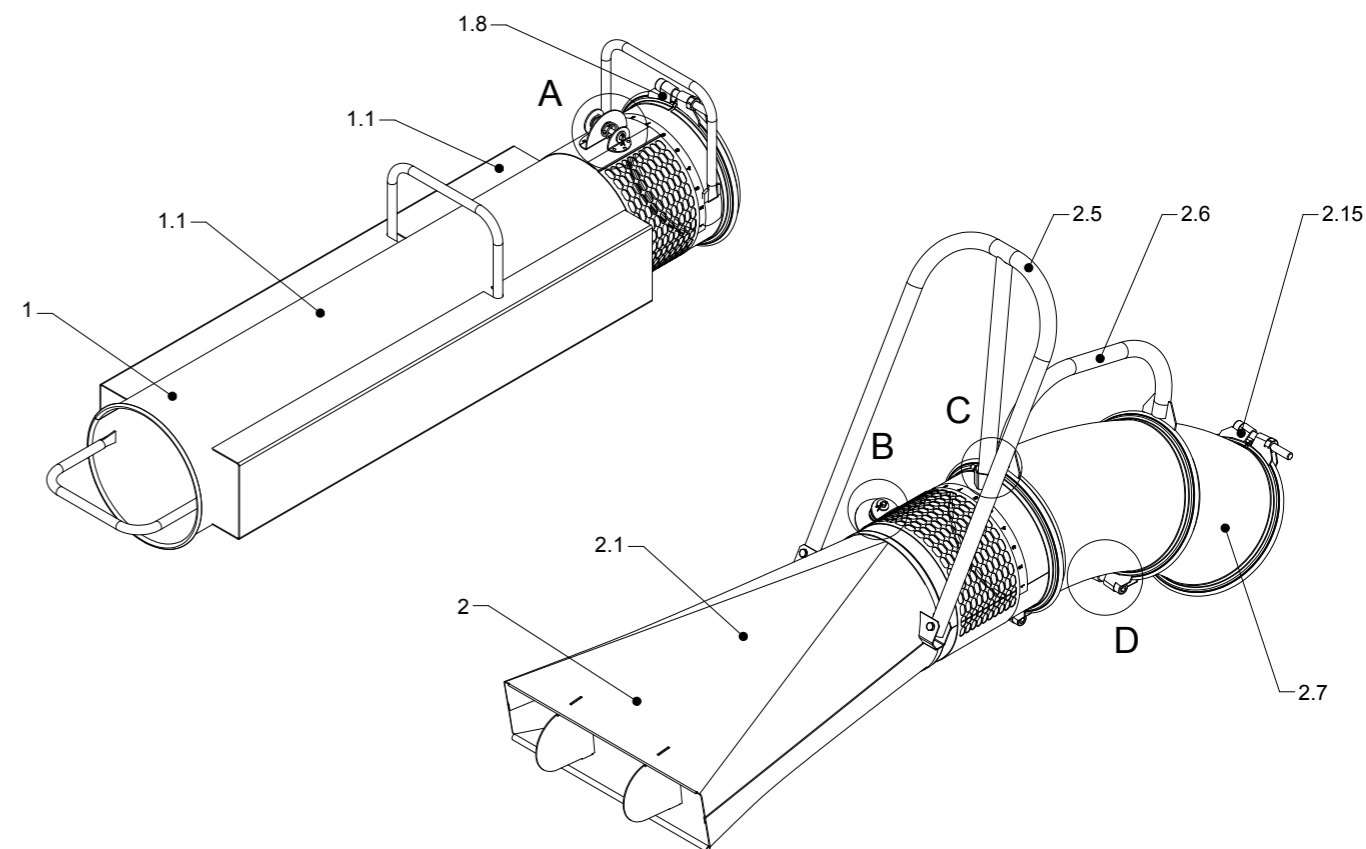

Pos.	Pieces	Part no.	Notes
1	1	121165006	Round suction head complete
1.1	1	121165422	
1.2	1	131080533	
1.3	1	121120113	
1.4	1	121120116	
1.5	1	100331013	Washer 1/4"
1.7	1	100333000	Split pin Ø2x15 mm
1.8	1	122050206	Clamp with bolt OK160, reinforced
2	1	121165007	Universal suction head complete
2.1	1	121165410	
2.2	1	131080533	
2.3	1	121120116	
2.4	1	100331013	Washer 1/4"
2.5	1	121165418	
2.6	1	121165427	
2.7	1	122050197	
2.8	1	121120113	
2.10	1	100333000	Split pin Ø2x15 mm
2.11	3	100306005	M6x40 DIN 931
2.12	3	100316002	M6 DIN 985-6
2.13	2	100323375	M10x90/90 DIN912 8,8
2.14	2	100315021	M10 DIN 934
2.15	1	122050206	Clamp with bolt OK160, reinforced