

Parts Manual

CPH-12, CPH-15, & CPH-20
Center Pivot Hitch
1994+

Great Plains

Manufacturing, Inc.

P.O. Box 5060 • Salina, Kansas 67402-5060



Read the Operator's manual entirely. When you see this symbol, the subsequent instructions and warnings are serious - follow without exception. Your life and the lives of others depend on it!

Great Plains

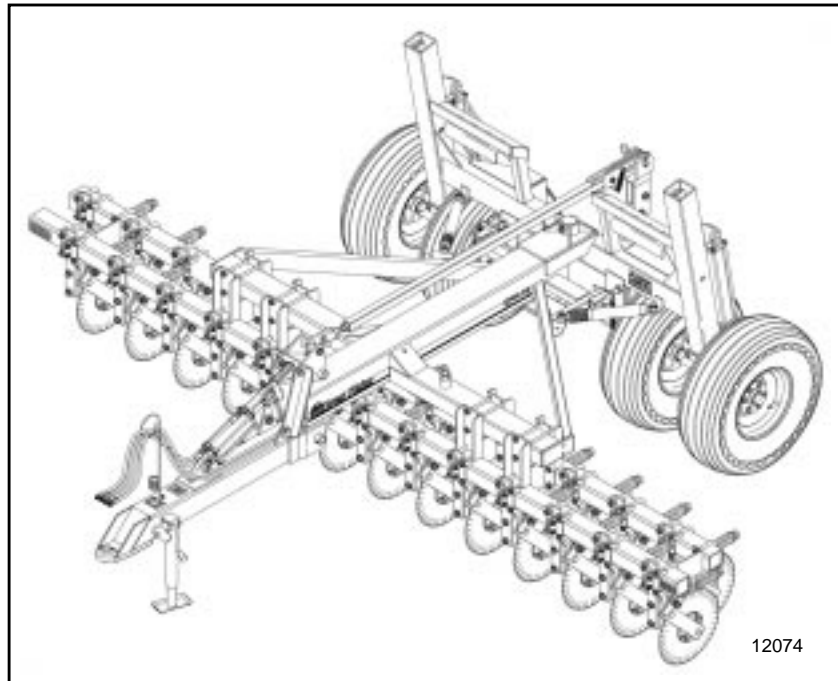

Cover illustration may show optional equipment not supplied with standard unit.

Table of Contents

Section 1 Introduction	1-1	Transport Cylinder 810-191C	5-7
General Information	1-1	Rephasing Transport Cylinder 810-192C	5-9
Revisions	1-1	Rephasing Transport Cylinder 810-193C	5-11
Touch-up Paint and Manual Information	1-1	Rephasing Transport Cylinder 810-194C	5-13
Replacement Hardware	1-1	Section 6 Coulter Command Option	6-1
Part Number Service Coding	1-2	Coulter Depth Control Hydraulics	6-1
Part Number Index	1-3	Coulter Command Electronics	6-3
Section 2 Frames	2-1	Coulter Command Gauge Wheel	6-5
Hitch Assembly	2-1	Top Link (Jan 1, 2001-)	6-7
Tongue	2-3	Coulter Command Switch Mount	6-9
Tool Bar	2-5	Lift Circuit Manifold (810-262C)	6-11
Main Frame	2-7	Coulter Depth Control Valve (810-214C)	6-13
Level Link	2-9	Seal Kit for Depth Control Valves	6-15
Section 3 Transport	3-1	Section 7 Decals	7-1
Transport Wheel	3-1	Decal Placement	7-1
Section 4 Coulters	4-1	Section 8 Options	8-1
Coulter (S/N 9791Z-)	4-1	Coulter Depth Control Hydraulics	8-1
Coulter (S/N 9792Z+)	4-3	Coulter Tool Bar Brace	8-3
Section 5 Hydraulics	5-1	Weight Frame Bracket (149-168A)	8-5
Hydraulics	5-1	John Deere Weight Bracket (149-032A)	8-7
Tongue Cylinder 810-195C	5-3	Case I.H. Weight Bracket (149-034A)	8-9
Rephasing Transport Cylinder 810-190C	5-5		

© Copyright 2000 All rights Reserved

Great Plains Manufacturing, Inc. provides this publication "as is" without warranty of any kind, either expressed or implied. While every precaution has been taken in the preparation of this manual, Great Plains Manufacturing, Inc. assumes no responsibility for errors or omissions. Neither is any liability assumed for damages resulting from the use of the information contained herein. Great Plains Manufacturing, Inc. reserves the right to revise and improve its products as it sees fit. This publication describes the state of this product at the time of its publication, and may not reflect the product in the future. The illustrations in this manual are not intended for safe and proper assembly or disassembly of equipment. The illustrations are intended for ordering parts only.

Great Plains Manufacturing, Incorporated Trademarks

The following are trademarks of Great Plains Mfg., Inc.: Application Systems, Ausherman, Land Pride, Great Plains

All other brands and product names are trademarks or registered trademarks of their respective holders.

Printed in the United States of America.

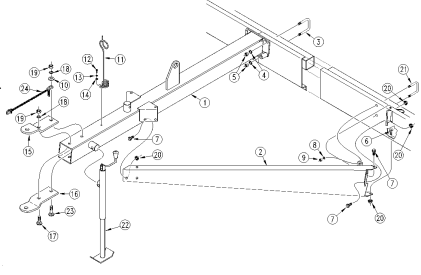
Section Number & Description	Serial Number Break	Illustration Page	Parts Page
<p>Section 2 Frames Tongue & Pull Bar (S/N 00000-) Great Plains Mfg., Inc.</p> <p>Illustration Heading</p>  <p>Illustration</p> <p>Illustration Number</p> <p>10207</p> <p>2-1 EWD13 13' End Wheel Drill 175-083P 5/21/98</p> <p>Left Page Number</p> <p>Manual Name & Number</p> <p>New or Modification Date</p>			<p>Great Plains Mfg., Inc. Section 2 Frames Tongue & Pull Bar (S/N 00000-)</p> <p>Parts List</p> <ol style="list-style-type: none"> 177-001H 13' END WHEEL TONGUE WELDMENT 177-004H PULL BAR WELDMENT LH 177-005H PULL BAR WELDMENT RH 806-032C U-BOLT 5/8-11 X 3 17/32 UNEVEN 804-022C WASHER LOCK SPRING 5/8 PLT 803-021C NUT HEX 5/8-11 PLT 802-183C RHSNB 1/2-13X1 GR5 802-083C HFSS 1/2-13X1 1/4 GR8 804-015C WASHER LOCK SPRING 1/2 PLT 803-020C NUT HEX 1/2-13 PLT 177-587D SAFETY CHAIN WASHER 807-023C SPRING HOSE LOOP 801-028C SCREW HEX 3/8-16X1 TYPE F 804-013C WASHER LOCK SPRING 3/8 PLT 804-012C WASHER FLAT 3/8 SAE PLT 177-009D CLEVIS HITCH TOP HALF 177-008D CLEVIS HITCH BOTTOM HALF 802-177C RHSNB 3/4-10X2 1/2 GR5 804-023C WASHER LOCK SPRING 3/4 PLT 803-027C NUT HEX 3/4-10 PLT 803-037C NUT HEX WHIZ 1/2-13 PLT 806-028C U-BOLT 1/2-13 X 3 17/32 X4 3/4 890-118C SCREW JACK 2000# 802-289C RHSNB 3/4-10X3 GR5 890-182C SAFETY CHAIN 10000 LB <p>7/1/98 EWD13 13' End Wheel Drill 175-083P 2-2</p> <p>Right Page Number</p>

General Information

Revisions

Please refer to the date at the bottom of each page for the most current version of the equipment. Serial number breaks are at the top of the page at the end of the illustration heading, refer to the illustration above.

Touch-up Paint and Manual Information

Repaint parts where paint is worn or scratched to prevent rust. Aerosol touch-up paint is available. To order use Great Plains part numbers below:

- GP Green821-001C
- GP Black821-002C
- GP Beige821-003C
- GP Buckskin821-004C
- LP Beige821-011C
- LP Black821-032C

Replacement manuals available. Use Great Plains part 148-152P.

Replacement Hardware

All bolts and nuts are grade 5 unless otherwise noted. The use of improper grades of hardware can result in personal injury, damage to equipment, or loss of property. See **“Hardware Legend”** on page 1-2, for hardware abbreviations used within all parts lists.

Hardware Legend

AR	As Required
BLADE	Blade Bolt
C	Cap Screw
CP	Cotter Pin
CPHSSS	Cup Point Hex Socket Set Screw
CPSHSS	Cup Point Square Head Set Screw
CPSQHSS	Cup Point Square Head Set Screw
CRFCHMS	Cross Recess Flat Countersunk Head Mach. Screw
CRPHMS	Cross Recess Pan Head Machine Screw
CRPHTFS	Cross Recess Pan Head Thread Forming
CRRHMS	Cross Recess Round Head Machine Screw
CRTHMS	Cross Recess Truss Head Machine Screw
CSNB	Countersunk Square Neck Bolt
FHMS	Flat Head Machine Screw
FTC	Full Thread Cap Screw
H	Hex Nut
HCLN	Hex Center Lock Nut
HFLCS	Hex Flange Lock Cap Screw
HFS	Hex Flange Screw
HFSLN	Hex Flange Serrated Lock Nut
HFSS	Hex Flange Serrated Screw
HHCS	Hex Head Cap Screw or Metric Bolt
HSBHCS	Hex Socket Button Head Cap Screw
HSFCHCS	Hex Socket Flat Countersunk Head Cap Screw
HSHCS	Hex Socket Head Cap Screw
HSSS	Hex Socket Head Screw
HTLN	Hex Top Lock Nut
HWHCS	Hex Washer Head Cap Screw

HWHMS	Hex Washer Head Machine Screw
HXBHCS	Hex Socket Button Head Cap Screw
J	Hex Jam Nut
JIC	37 Degree Tapered Thread
L	Helical Spring Lock Washer
LUG	Lug Bolt
NFC	National Fine Cap Screw
NPSM	National Pipe Straight Mechanical
NPTF	National Pipe Taper Fuel
P	Wide Plain Washer
PHMS	Pan Head Machine Screw
PLOW	Plow Bolt
RHMS	Round Head Machine Screw
RHSNB	Round Head Square Neck Bolt
SCREW LEVELING	Leveling Screw
SCREW THUMB	Thumb Screw
SCREW WELD	Weld Screw
SFCHMS	Slotted Flat Countersunk Head Machine Screw
SFHMS	Slotted Fillister Head Machine Screw
SP	Special
SP SCREW	Special Screw
SQHSS	Square Head Set Screw
SRHMS	Slotted Round Head Machine Screw
SSS	Socket Set Screw
STCS	Self Tapping Cap Screw
STHMS	Slotted Truss Head Machine Screw
WHEEL	Wheel Studs and Hub Long Bolts
WING	Wing Bolt

Part Number Service Coding

Within the following parts lists some part numbers are coded for revisions and interchangeability.

Legend:

Newest serial numbers are listed first.

Bold face type indicates parts that are serviced. These parts are considered interchangeable, if it supersedes another part, unless otherwise noted.

Example:

- (S/N 20001+) Includes serial numbers 20001 and above (to the newest numbers)
- (S/N 10001↔20000) Includes serial numbers between and including 10001 and 20000
- (S/N 10000-) Includes serial numbers 10000 and below (to the oldest number)

- ① First revision, e.g.; ② is 2nd revision, ③ is 3rd revision, etc.
(Greater numbers are the newest.)
- The existing stock for this part should be used up before ordering the new part.
- ⊗ Not interchangeable
- ⊗①② Revision 2 is not interchangeable w/1

Not interchangeable with revision 1

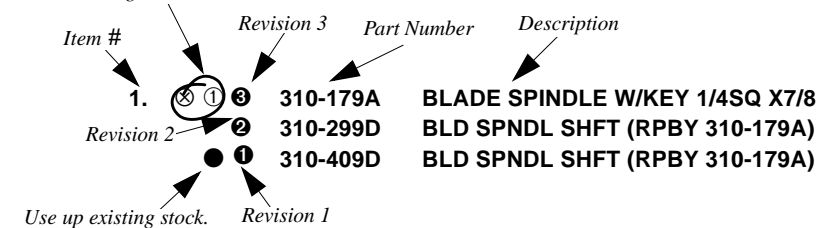

Part Number Index

Part Number	Page	Part Number	Page	Part Number	Page	Part Number	Page
04003013	6-6	148-381D	6-6	2A0012	5-4	802-059C	2-10
10000001	6-12	148-382D	6-6	2A0012	5-6	802-059C	2-8
30102610	6-14	148-413D	6-6	2A0012	5-8	802-059C	6-8
30102663	6-12	148-415D	6-2	2A0014	5-4	802-059C	8-10
33702007	6-12	148-424D	2-4	2A0014	5-6	802-064C	8-4
34702171	6-12	148-426D	6-6	2A0016	5-10	802-065C	8-10
34952061	6-12	148-500D	6-10	2A0016	5-8	802-073C	6-8
34952104	6-14	148-502D	6-10	2A0018	5-12	802-075C	2-4
39680008	6-12	148-507D	6-6	2A0019	5-14	802-082C	4-2
39680008	6-14	148-510D	6-10	2A0024	5-10	802-091C	6-6
61000000	6-12	148-004D	4-2	2A0024	5-12	802-092C	6-6
61000000	6-14	148-141H	2-8	2A0024	5-14	802-095C	8-8
62010018	6-12	148-268D	2-8	2A0024	5-4	802-096C	2-4
62010053	6-14	149-004D	4-2	2A0024	5-6	802-099C	3-2
62010056	6-14	149-046D	8-10	2A0024	5-8	802-103C	4-2
85002006	6-14	149-057H	8-10	2A0132	5-4	802-104C	3-2
85002279	6-14	149-058H	8-6	2A0208	5-4	802-104C	6-6
85002929	6-12	149-059D	4-2	2M4416	5-4	802-112C	8-8
86020028	6-12	149-059H	8-8	2M4434	5-6	802-123C	8-4
86020224	6-12	149-069D	2-6	2M5434	5-10	802-128C	6-6
87410001	6-12	149-070D	2-6	2M5434	5-8	802-152C	6-10
87410043	6-14	149-071D	2-6	2M6832	5-12	802-164C	2-2
102-004K	3-2	149-072D	2-6	2M7532	5-14	802-178C	2-8
102-005K	3-2	149-072D	8-6	3R1412	5-4	802-181C	2-8
124-016H	2-8	149-073D	2-6	3R1412	5-6	802-205C	2-10
124-017H	2-8	149-074D	2-6	3R2412	5-8	802-208C	2-6
124-018H	2-8	149-165H	8-4	3R3412	5-10	802-208C	8-6
124-105D	2-8	149-166H	8-4	3R5812	5-12	802-214C	4-2
148-022D	2-8	149-167H	8-4	3R6912	5-14	802-258C	2-4
148-023D	2-8	149-552D	4-2	4M4104	5-4	802-262C	2-6
148-044H	2-8	149-558D	4-4	4R1106	5-6	802-279C	6-2
148-082H	2-4	149-559D	4-4	4R2106	5-8	802-281C	2-4
148-084H	6-8	149-962S	4-2	4R3106	5-10	802-298C	2-4
148-085H	2-10	152-215D	3-2	4R5108	5-12	802-298C	2-4
148-085H	6-8	155-054D	2-8	4R6108	5-14	802-333C	6-2
148-113D	2-10	155-164D	2-8	5M4116	5-4	802-335C	2-6
148-122D	2-8	161-036H	2-4	5R1132	5-6	802-335C	8-6
148-136D	2-8	194-070D	2-4	5R2132	5-8	802-380C	5-2
148-142H	3-2	1M7016	5-10	5R3132	5-10	802-399C	3-2
148-146H	2-4	1M7016	5-12	5R5132	5-12	802-429C	2-2
148-147H	3-2	1M7016	5-14	5R6132	5-14	802-055C	2-8
148-148H	2-10	1M7016	5-4	6R1164	5-4	802-082C	4-4
148-149H	2-10	1M7016	5-6	6R1164	5-6	802-095C	2-8
148-150H	2-2	1M7016	5-8	6R2164	5-8	802-103C	4-4
148-154H	5-2	200-001D	3-2	6R3164	5-10	802-214C	4-4
148-157K	2-10	200-001D	4-2	6R3164	5-10	802-718C	4-4
148-160H	5-2	200-001D	6-6	6R5164	5-12	803-001C	6-10
148-161H	5-2	200-002S	4-2	6R6164	5-14	803-006C	6-10
148-162H	5-2	200-003D	3-2	7M4316	5-4	803-008C	6-10
148-163H	2-2	200-026S	3-2	7M4412	5-6	803-008C	6-2
148-177H	6-6	200-039V	4-2	7M5412	5-10	803-008C	6-6
148-197H	6-6	200-039V	4-2	7M5412	5-8	803-013C	2-8
148-198H	6-8	200-001D	4-4	7M6426	5-12	803-019C	3-2
148-199H	6-6	200-013D	3-2	7M7426	5-14	803-020C	2-8
148-212D	2-10	200-039V	4-4	800-001C	2-4	803-020C	4-2
148-217V	6-8	201-012D	2-8	800-001C	2-8	803-020C	6-2
148-224D	2-4	201-006D	4-2	800-001C	4-2	803-020C	6-6
148-225D	2-4	204-075H	4-2	800-001C	6-6	803-021C	2-6
148-226D	2-4	204-107D	4-2	800-001C	6-6	803-021C	2-8
148-246S	6-6	204-272D	4-4	800-148C	6-6	803-021C	4-2
148-247H	6-10	249-050S	4-4	800-149C	6-6	803-021C	6-6
148-254D	2-8	249-051H	4-4	800-001C	4-4	803-021C	6-6
148-256H	2-4	2A0006	5-10	800-164C	4-4	803-021C	8-10
148-264H	6-10	2A0006	5-12	800-177C	4-4	803-021C	8-4
148-266S	8-2	2A0006	5-14	801-017C	6-6	803-021C	8-6
148-283H	6-2	2A0006	5-4	801-023C	2-8	803-023C	2-8
148-296D	2-4	2A0006	5-6	801-036C	2-8	803-024C	2-10
148-297D	2-2	2A0006	5-8	801-051C	6-6	803-024C	2-4
148-297D	2-4	2A0012	5-10	801-085C	6-10	803-024C	2-8
		2A0012	5-12	802-010C	6-10	803-024C	6-8
		2A0012	5-14	802-041C	6-6	803-027C	2-2
				802-046C	6-2	803-027C	2-8

Part Number Index

Part Number	Page	Part Number	Page	Part Number	Page	Part Number	Page
803-027C	8-10	804-030C	2-4	810-191C	5-2	818-016C	7-2
803-027C	8-4	804-030C	8-4	810-191C	5-2	820-018C	4-2
803-027C	8-8	804-037C	2-8	810-192C	5-2	820-082C	4-2
803-029C	3-2	804-037C	4-2	810-193C	5-2	820-116C	4-2
803-029C	4-2	804-039C	4-2	810-194C	5-2	820-018C	4-4
803-029C	6-6	804-046C	6-10	810-195C	2-4	820-082C	4-4
803-030C	2-8	804-050C	6-6	810-195C	5-2	820-116C	4-4
803-031C	2-10	804-054C	6-10	810-211C	5-6	820-156C	4-2
803-031C	2-2	804-055C	3-2	810-214C	6-2	820-156C	4-4
803-031C	2-4	804-055C	4-2	810-228C	6-16	822-018C	3-2
803-031C	6-8	804-055C	6-6	810-235C	6-16	822-019C	3-2
803-034C	2-10	804-109C	6-6	810-259C	6-2	822-020C	3-2
803-034C	2-4	804-015C	4-4	810-259C	6-6	822-020C	4-2
803-034C	6-8	804-019C	2-8	810-262C	6-2	822-021C	3-2
803-036C	5-2	804-022C	2-8	810-265C	6-14	822-021C	4-2
803-038C	2-4	804-022C	4-4	810-271C	6-16	822-040C	6-6
803-048C	4-2	804-037C	4-4	810-272C	6-16	822-041C	6-6
803-049C	2-8	804-055C	4-4	810-442C	5-2	822-048C	3-2
803-049C	4-2	804-156C	4-4	810-443C	5-2	822-053C	3-2
803-056C	2-8	804-165C	4-4	811-059C	5-2	822-056C	2-8
803-068C	6-6	805-004C	2-4	811-063C	5-2	822-091C	6-6
803-079C	2-8	805-004C	6-2	811-063C	6-2	822-092C	6-6
803-084C	6-10	805-010C	2-4	811-065C	6-2	822-021C	4-4
803-147C	5-2	805-010C	6-2	811-088C	6-2	823-103C	6-4
803-181C	4-2	805-016C	2-8	811-172C	6-2	823-104C	6-4
803-012C	2-8	805-016C	3-2	811-272C	5-2	823-105C	6-6
803-020C	4-4	805-016C	6-6	811-280C	6-2	823-106C	6-6
803-021C	4-4	805-017C	4-2	811-289C	5-2	823-107C	6-10
803-029C	4-4	805-021C	2-4	811-331C	6-2	823-108C	6-4
803-048C	4-4	805-021C	4-2	811-340C	6-2	823-110C	6-4
803-049C	4-4	805-021C	6-2	811-383C	6-2	838-160C	7-2
804-004C	6-6	805-032C	2-4	811-443C	6-2	838-265C	7-2
804-006C	6-10	805-033C	2-8	812-015C	8-8	890-005C	2-4
804-007C	6-10	805-037C	2-8	812-016C	8-10	890-011C	2-4
804-009C	6-10	805-041C	2-8	812-017C	8-8	890-183C	2-4
804-009C	6-2	805-043C	2-4	812-018C	8-10	890-246C	2-4
804-009C	6-6	805-067C	6-6	812-019C	8-10	890-285C	2-4
804-010C	6-10	805-085C	2-8	814-008C	3-2	890-389C	4-2
804-012C	6-6	805-128C	6-6	814-009C	3-2		
804-015C	2-4	805-146C	6-6	814-015C	3-2		
804-015C	2-8	805-149C	2-10	814-023C	3-2		
804-015C	4-2	805-152C	2-4	814-032C	3-2		
804-015C	6-10	805-152C	8-2	814-115C	6-6		
804-015C	6-2	805-017C	4-4	814-116C	6-6		
804-015C	6-6	805-044C	2-8	814-145C	3-2		
804-017C	2-4	805-246C	3-2	815-013C	3-2		
804-017C	5-2	805-331C	4-4	816-009C	4-2		
804-017C	6-6	806-013C	2-8	816-011C	3-2		
804-019C	2-6	806-014C	2-8	816-033C	3-2		
804-019C	8-6	806-063C	8-4	816-035C	6-6		
804-021C	2-8	806-105C	2-6	816-039C	2-8		
804-021C	8-10	806-105C	4-2	816-098C	6-6		
804-022C	2-6	806-105C	6-6	816-193C	6-6		
804-022C	4-2	806-105C	8-6	816-009C	4-4		
804-022C	6-6	806-105C	4-4	817-029C	4-2		
804-022C	8-10	807-007C	2-8	817-051C	4-2		
804-022C	8-4	807-009C	2-8	817-084C	6-6		
804-022C	8-6	807-012C	2-8	817-129C	6-6		
804-023C	2-2	807-026C	2-8	817-154C	2-6		
804-023C	2-8	807-063C	2-10	817-155C	2-6		
804-023C	8-10	807-063C	6-8	817-170C	6-10		
804-023C	8-4	807-073C	2-4	817-398C	2-8		
804-023C	8-8	807-078C	5-2	817-438C	2-8		
804-024C	2-2	810-015C	5-4	817-513C	4-4		
804-027C	2-10	810-026C	2-8	818-019C	7-2		
804-027C	2-2	810-144C	5-14	818-181C	2-4		
804-027C	2-4	810-151C	5-12	818-181C	7-2		
804-027C	6-8	810-173C	5-8	818-188C	7-2		
804-029C	2-4	810-174C	5-10	818-229C	7-2		
804-029C	6-2	810-190C	5-2	818-398C	7-2		

Part Number Index

<u>Part Number</u>	<u>Page</u>	<u>Part Number</u>	<u>Page</u>	<u>Part Number</u>	<u>Page</u>	<u>Part Number</u>	<u>Page</u>
--------------------	-------------	--------------------	-------------	--------------------	-------------	--------------------	-------------

Hitch Assembly

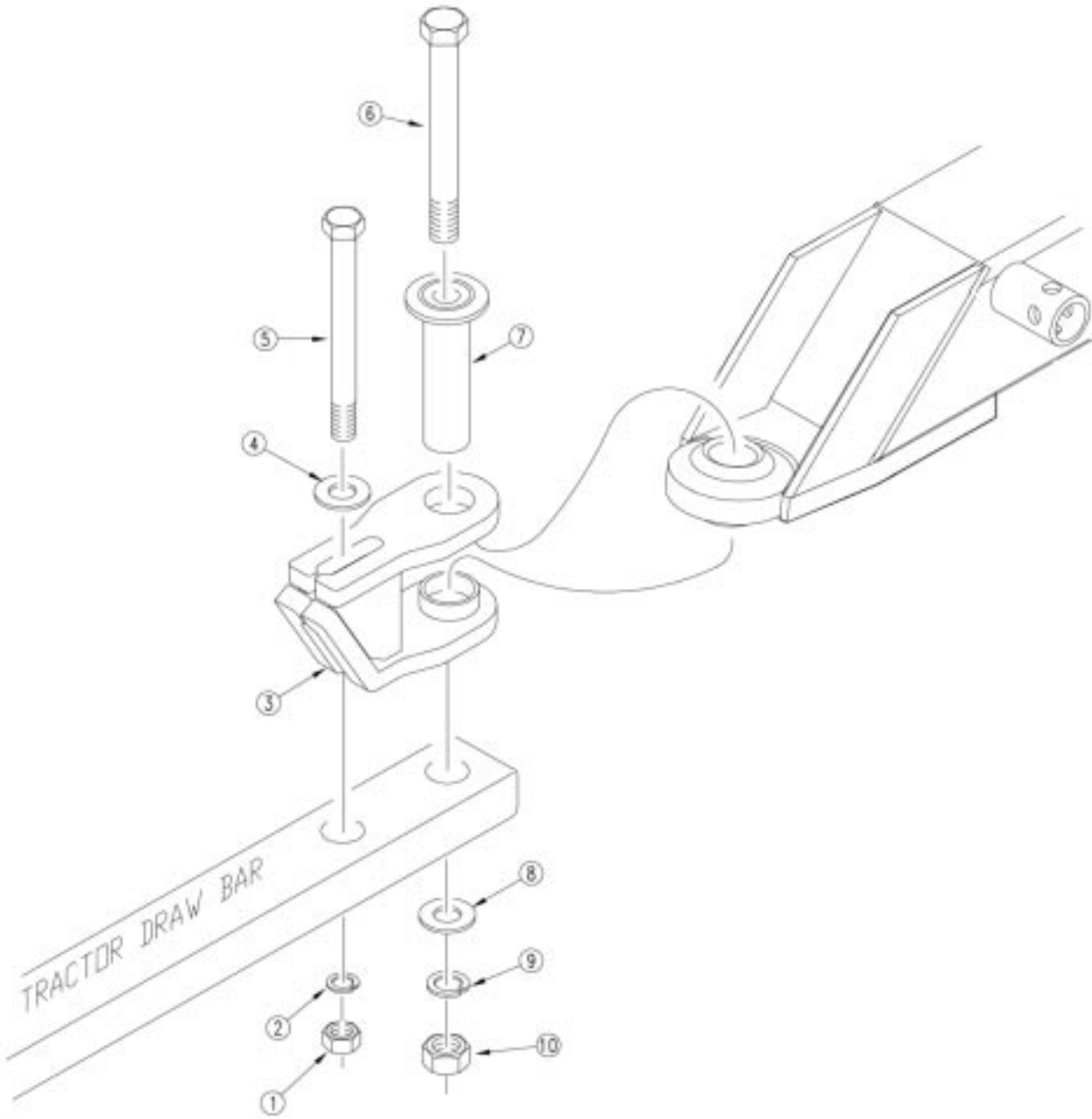

11616

Hitch Assembly

Ref.	Part No.	Part Description	Comments
1.	803-027C	NUT HEX 3/4-10 PLT	
2.	804-023C	WASHER LOCK SPRING 3/4 PLT	
3.	148-150H	FRONT HITCH WELDMENT	
4.	804-024C	WASHER FLAT 3/4 USS PLT	
5.	802-164C	HHCS 3/4-10X9 GR5	
6.	802-429C	HHCS 1-8X10 GR5 PLT	
7.	148-163H	FRONT HITCH INNER TUBE WLDMT	
8.	148-297D	3OD X 1 1/32ID X 3/8 WASHER	
9.	804-027C	WASHER LOCK SPRING 1 PLT	
10.	803-031C	NUT HEX 1-8 PLT	

Legend: ① = 1st revision; ② = 2nd revision; ③ = 3rd revision; ● = use up existing stock; ⊗ = not interchangeable; ⊗ ① ② = for example: revision 2 is not interchangeable w/revision 1

Tongue

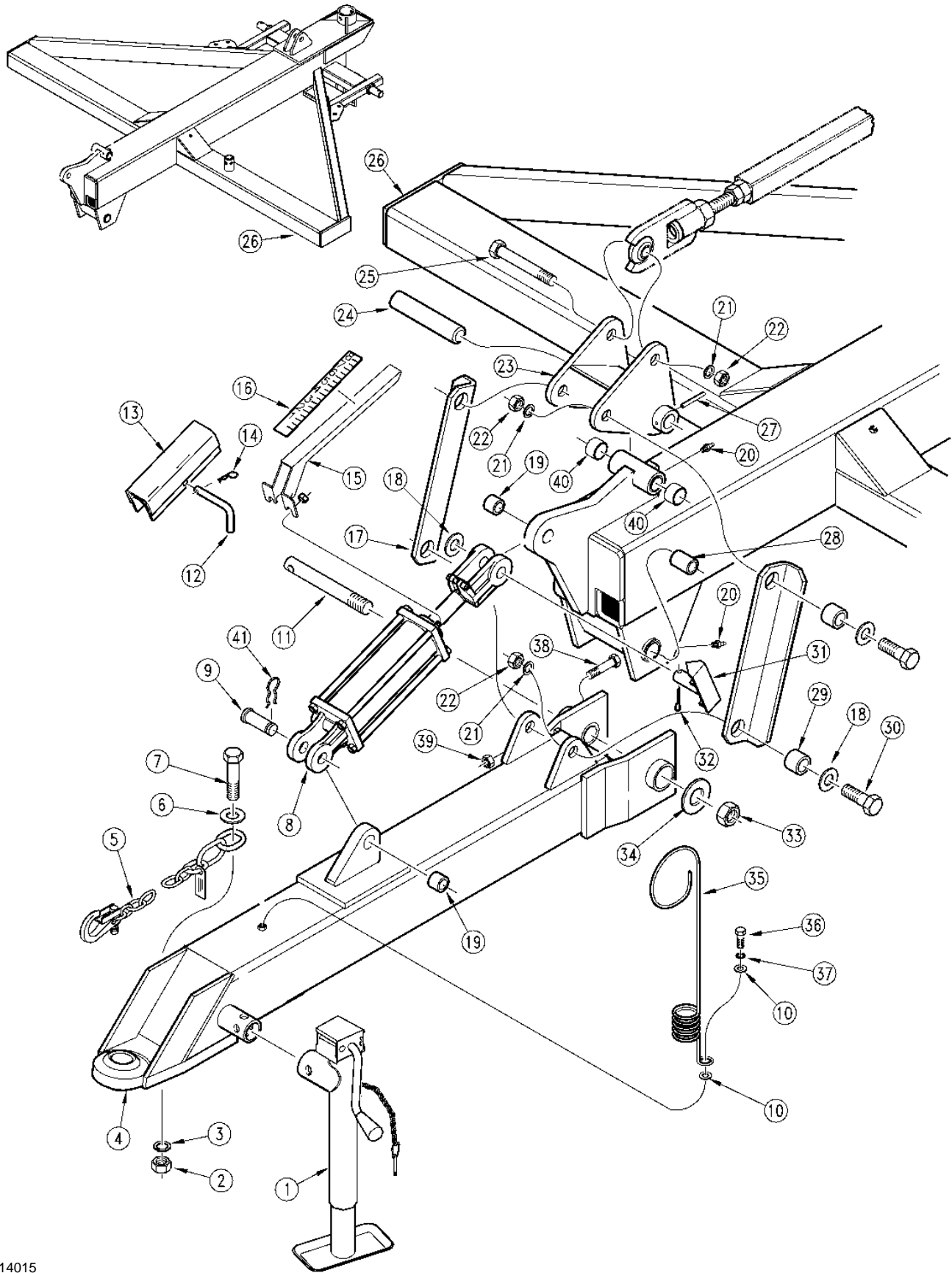

14015

Tongue

Ref.	Part No.	Part Description	Comments
1.	890-246C	SCREW JACK 5000# 15-30	
2.	803-034C	NUT HEX 1 1/4-7 PLT	
3.	804-030C	WASHER LOCK 1 1/4 SPRING PLT	
4.	148-256H	FRONT TONGUE WELDMENT	
5.	890-183C	SAFETY CHAIN 20000 LB	
6.	194-070D	SAFETY CHAIN WASHER	
7.	802-298C	HHCS 1 1/4-7X4 GR5	
8.	810-195C	CYL 3X8X1.25 ROD (TIE) NO PINS	Refer to Section 5 page 4 for break-down.
9.	805-004C	PIN CLEVIS 1 X 2 3/4 USABLE LG	
10.	804-017C	WASHER FLAT 1/2 USS PLT	
11.	148-424D	TONGUE REAR CROSS PIN	
12.	805-152C	BENT PIN 3/8 X 2 1/2 USE W/COT	
13.	161-036H	CYLINDER LOCK CHANNEL	
14.	805-010C	PIN HAIR COTTER .094	
15.	148-296D	DEPTH INDICATOR PLATE	
16.	818-181C	DECAL STROKE GAUGE	
17.	148-224D	TONGUE LINK	
18.	804-029C	WASHER FLAT 1 SAE	
19.	890-005C	BUSHING CYL 1 1/4 X 1 X 1	
20.	800-001C	GREASE ZERK STRAIGHT 1/4-28	
21.	804-027C	WASHER LOCK SPRING 1 PLT	
22.	803-031C	NUT HEX 1-8 PLT	
23.	148-082H	LEVEL LINK PIVOT LEVER	
24.	148-226D	LINK PIVOT CROSS PIN	
25.	802-075C	HHCS 1-8X7 GR5	
26.	148-146H	CENTER PIVOT HITCH TONGUE	
27.	805-043C	PIN SPIROL 3/8X2 1/2 PLAIN	
28.	890-285C	BUSHING 1 3/4X1 1/2X3 1/2LONG	
29.	148-225D	CLEVIS PIVOT TUBE	
30.	802-096C	HHCS 1-8X2 1/2 GR5	
31.	⊕ 148-387H	STROKE GAUGE POINTER 3000PSI	For 2 1/2" clevis
	Ⓜ 148-159H	STROKE GAUGE POINTER	For 2" clevis
32.	805-021C	PIN COTTER 1/4 X 2 PLT	
33.	803-038C	NUT HEX 1-8 NYLON INSERT PLT	
34.	148-297D	3OD X 1 1/32ID X 3/8 WASHER	
35.	807-073C	SPRING HOSE LOOP HEAVY	
36.	802-258C	HHCS 1/2-13X1 GR5	
37.	804-015C	WASHER LOCK SPRING 1/2 PLT	
38.	802-281C	HHCS 5/8-11X2 3/4 GR5	
39.	803-024C	NUT LOCK 5/8-11 PLT	
40.	890-011C	BUSHING SPINDLE 1 1/2X1 1/4X1	
41.	805-032C	PIN HAIR COTTER .148 WIRE	

Legend: Ⓜ = 1st revision; ⊕ = 2nd revision; ⊕ = 3rd revision; ● = use up existing stock; ⊗ = not interchangeable; ⊗ ⊕ ⊕ = for example: revision 2 is not interchangeable w/revision 1

Tool Bar

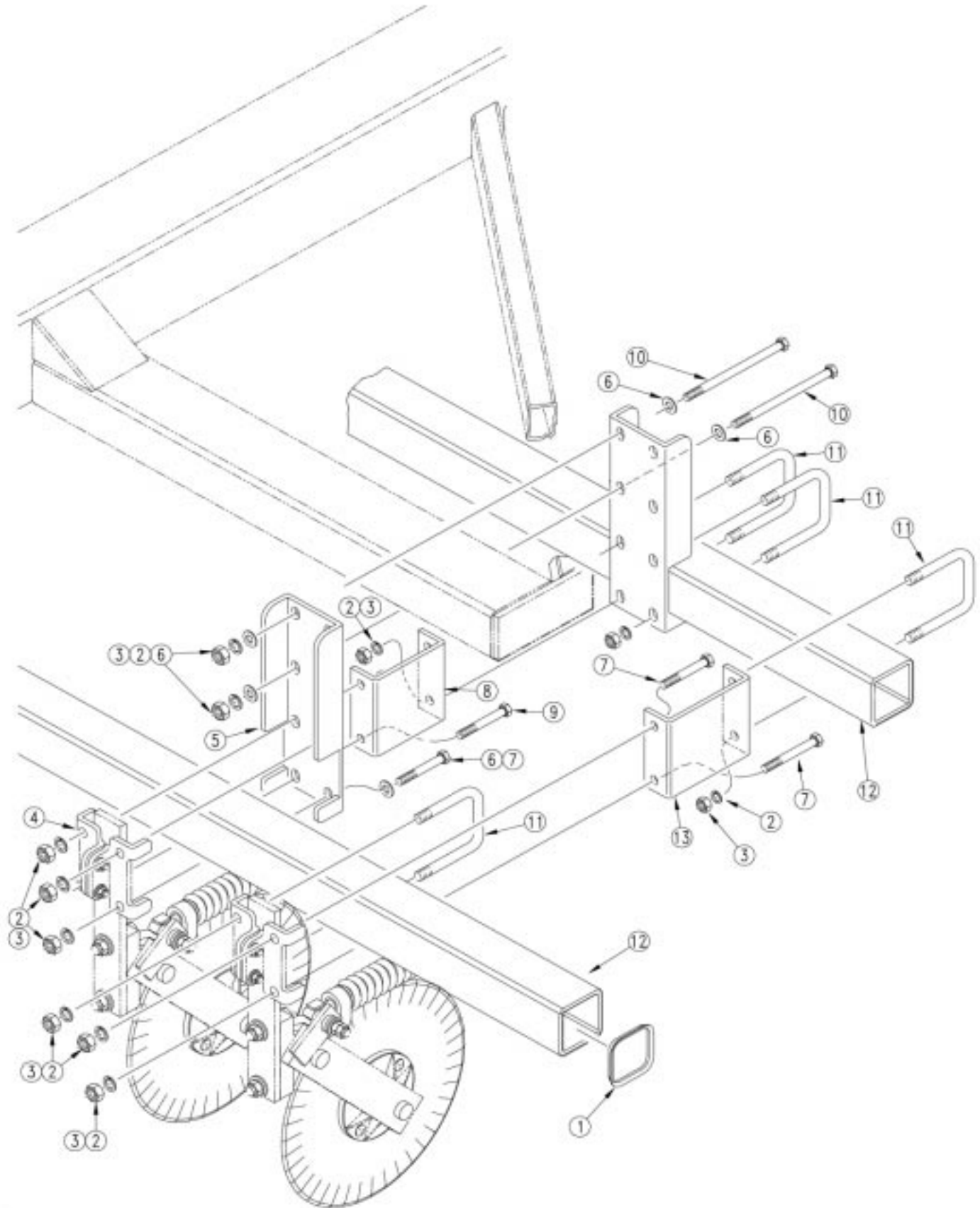

11981

Tool Bar

Ref.	Part No.	Part Description	Comments
1.	817-155C 817-154C	4 X 4 X 1/4 END CAP 4 X 4 X 3/16 END CAP	
2.	804-022C	WASHER LOCK SPRING 5/8 PLT	
3.	803-021C	NUT HEX 5/8-11 PLT	
4.			Coulter Assembly refer to Section 4 page 2.
5.	149-072D	COULTER BAR CLAMP	
6.	804-019C	WASHER FLAT 5/8 USS PLT	
7.	802-335C	HHCS 5/8-11X6 1/2 GR5	
8.	149-073D	COULTER BAR CHANNEL BRACE	
9.	802-262C	HHCS 5/8-11X7 GR5	
10.	802-208C	HHCS 5/8-11X8 GR5	
11.	806-105C	U-BOLT 5/8-11 X 4 1/32 X 6	
12.	149-069D	12' COULTER TOOL BAR TUBE	
	149-070D	15' COULTER TOOL BAR TUBE	
	149-071D	20' COULTER TOOL BAR TUBE	
13.	149-074D	COULTER TOOL BAR TIE STRAP	

Legend: ● = 1st revision; ● = 2nd revision; ● = 3rd revision; ● = use up existing stock; ⊗ = not interchangeable; ⊗ ① ● = for example: revision 2 is not interchangeable w/revision 1

Main Frame

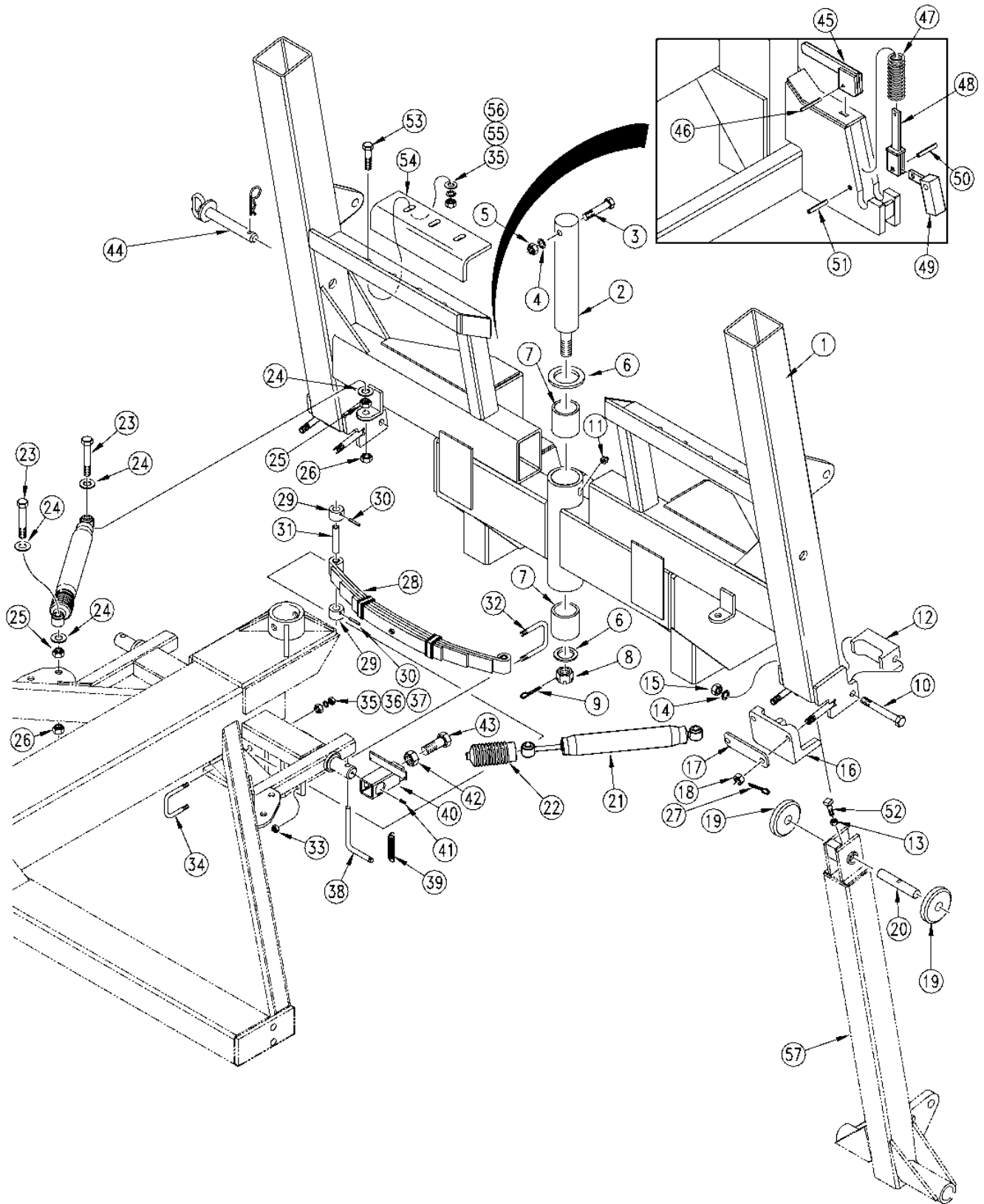

11720

Main Frame

Ref.	Part No.	Part Description	Comments
1.	148-141H	PULL HITCH AXLE FRAME	
2.	201-012D	PIVOT SHAFT	
3.	802-178C	HHCS 7/8-9X5 1/2 GR5	
4.	804-037C	WASHER LOCK SPRING 7/8 PLT	
5.	803-049C	NUT HEX 7/8-9 PLT	
6.	148-136D	REPLACED BY 804-102C	
7.	822-056C	BRONZE PIVOT BEARING 3.25 I.D.	
8.	803-079C	NUT HEX SLOTTED 1 1/4 - 7	
9.	805-085C	PIN COTTER 5/16 X 2 1/2	
10.	802-095C	HHCS 3/4-10X7 GR5	
11.	800-001C	GREASE ZERK STRAIGHT 1/4-28	
12.	817-398C	15 FT CPH SLIDE BLOCK	
13.	803-012C	NUT HEX JAM 3/8-16 PLT	
14.	804-023C	WASHER LOCK SPRING 3/4 PLT	
15.	803-027C	NUT HEX 3/4-10 PLT	
16.	817-438C	FRONT SLIDE BLOCK	
17.	148-254D	FRONT SLIDE BLOCK BACK PLATE	
18.	803-056C	NUT HEX SLOTTED 5/8-11 PLT GR5	
19.	155-164D	UPPER ROLLER MACHINED	
20.	155-054D	UPPER ROLLER SHAFT	
21.	810-026C	CYLINDER STABILIZER	
22.	816-039C	STABILIZER CYL. BOOT	
23.	802-059C	HHCS 5/8-11X3 GR5	
24.	804-021C	WASHER FLAT 5/8 SAE PLT	
25.	803-023C	NUT HEX JAM 5/8-11 PLT	
26.	803-024C	NUT LOCK 5/8-11 PLT	
27.	805-016C	PIN COTTER 3/16 X 1 1/4 PLT	
28.	807-012C	SPRING LEAF 4 LEAVES	
	807-009C	SPRING LEAF	
29.	148-023D	ROLLER STOP	
30.	805-041C	PIN ROLL 1/4X1 3/4	
31.	148-022D	ROLLER STOP PIN	
32.	806-014C	U-BOLT 3/8-16 X 1 7/8 X 8 GR 5	
33.	803-013C	NUT LOCK 3/8-16 PLT	
34.	806-013C	U-BOLT 1/2-13 X 1 13/16 X3 3/4	
35.	803-021C	NUT HEX 5/8-11 PLT	
36.	804-015C	WASHER LOCK SPRING 1/2 PLT	
37.	803-020C	NUT HEX 1/2-13 PLT	
38.	148-122D	FRAME SPRING ROD	
39.	807-026C	PIVOT STOP SPRING	
40.	148-044H	PIVOT LOCK	
41.	801-023C	SCREW SET SH 3/8-16X3/8 TYPE C	
42.	803-030C	NUT HEX JAM 1-8 PLT	
43.	802-181C	HHCS 1-8X3 GR5 FTHD	
44.	805-033C	PIN HITCH 1 X 6 W/HAIRPIN	
45.	124-016H	LOCK HANDLE WELDMENT	
46.	805-044C	PIN ROLL 1/4 X 1 PLATED	
47.	807-007C	SPRING LEVER	
48.	124-017H	SPRING LEVER WELDMENT	
49.	124-018H	PIN LOCK WELDMENT	
50.	124-105D	PIN LOCK PIVOT PIN	
51.	805-037C	PIN SPIROL 1/2X2 1/2 PLAIN	
52.	801-036C	SCREW SET SQ HD 3/8-16 X 3/4CP	
53.	802-055C	HHCS 5/8-11X2 GR5	
54.	148-268D	WEIGHT BRKT ADJUSTMENT LEG	
55.	804-022C	WASHER LOCK SPRING 5/8 PLT	
56.	804-019C	WASHER FLAT 5/8 USS PLT	
57.	148-147H	INNER AXLE SLIDE TUBE WELDMENT	
	148-142H	INNER AXLE SLIDE TUBE WLDT-20	

Legend: ● = 1st revision; ● = 2nd revision; ● = 3rd revision; ● = use up existing stock; ⊗ = not interchangeable; ⊗ ⊕ ● = for example: revision 2 is not interchangeable w/revision 1

Level Link

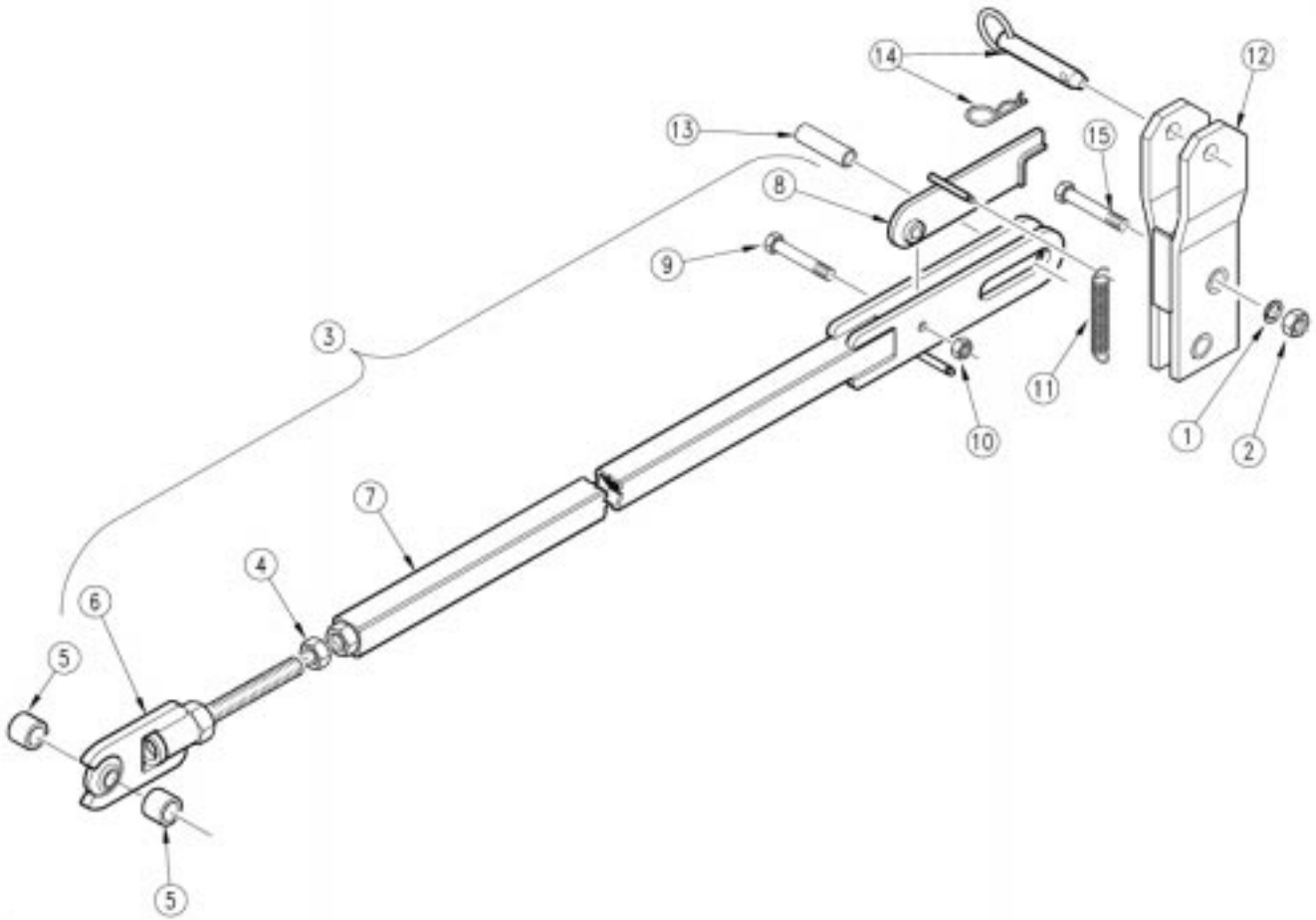

11758

Level Link

Ref.	Part No.	Part Description	Comments
1.	804-027C	WASHER LOCK SPRING 1 PLT	
2.	803-031C	NUT HEX 1-8 PLT	
3.	148-157K	94 CPH LEVEL LINK TUBE ASSY	Includes items 4, 6 - 11
4.	803-034C	NUT HEX 1 1/4-7 PLT	
5.	148-212D	BALL JOINT SPACER TUBE	
6.	148-085H	LEVEL LINK ADJUSTER	
7.	148-148H	LEVEL LINK WELDMENT	
8.	148-084H	LEVEL LINK LOCK PLATE	
9.	802-059C	HHCS 5/8-11X3 GR5	
10.	803-024C	NUT LOCK 5/8-11 PLT	
11.	807-063C	SPRING, LEVEL LINK LOCK	
12.	148-149H	HITCH EXTENSION	
13.	148-113D	HITCH BAR SLEEVE	
14.	805-149C	PIN HITCH 1 X 3 3/4 USABLE PLT	
15.	802-205C	HHCS 1-8X5 1/2 GR5	

Legend: ● = 1st revision; ● = 2nd revision; ● = 3rd revision; ● = use up existing stock; ⊗ = not interchangeable; ⊗ ① ● = for example: revision 2 is not interchangeable w/revision 1

Transport Wheel

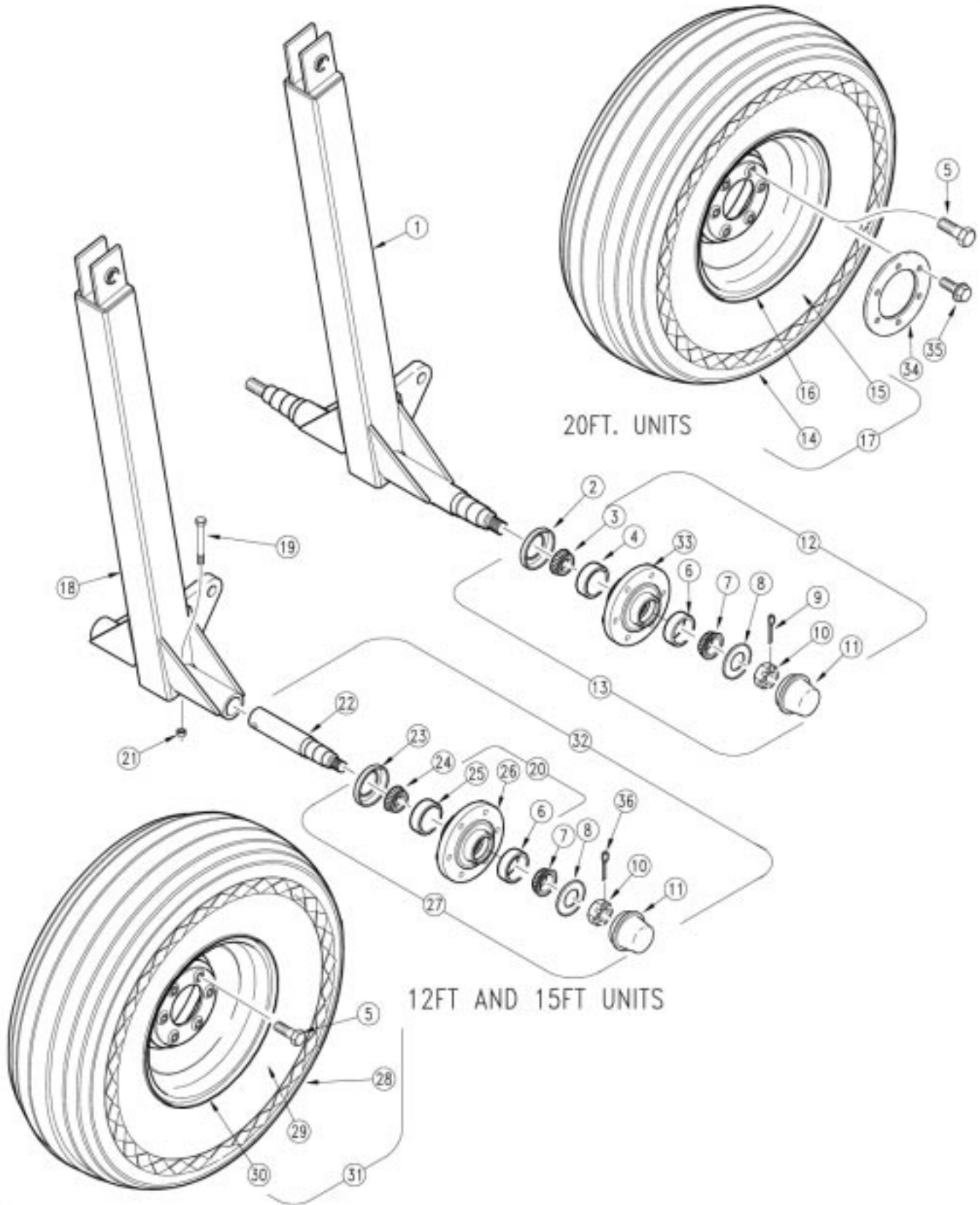

11832

Transport Wheel

Ref.	Part No.	Part Description	Comments
1.	148-142H	INNER AXLE SLIDE TUBE WLDT-20	
2.	816-033C	SEAL 3 X 2.25 X .25 CR 22368	
3.	822-048C	BEARING CONE #LM 501349	
4.	822-053C	BEARING CUP #LM 501310	
5.	802-104C	BOLT WHEEL 1/2-20X1 90-DEG	
6.	822-020C	BEARING CUP LM-67010	
7.	822-021C	BEARING CONE LM-67048	
8.	804-055C	WASHER SPINDLE - 7/8	
9.	805-016C	PIN COTTER 3/16 X 1 1/4 PLT	
10.	803-029C	NUT HEX SLOTTED 7/8-14 PLT	
11.	200-001D	HUB GREASE CAP	
12.	815-013C	6H-06AA HUB PACKAGE LESS SEAL	Includes items 3, 4, 6, 7, 11, 33
13.	200-026S	20' CDH HUB ASSEMBLY	Includes items 2, 5, 12
14.	814-145C	TIRE 11L-15SL 12 PLY TUBE TYPE	
15.	814-032C	TUBE 11L X 15SL W/CAL STEM	
16.	814-023C	WHEEL 15 DIA X 10 WIDE X 6 BLT	
17.	102-004K	TRANSPORT WHEEL & TIRE ASSY.	Includes items 14, 15, 16
18.	148-147H	INNER AXLE SLIDE TUBE WELDMENT	
19.	802-099C	HHCS 1/2-13X3 1/4 GR5	
20.	⊗ 815-082C	HUB 6 BOLT 4 5/8 PILOT W/ CUPS	
	Ⓜ 200-037V	REPLACED BY 815-082C	
21.	803-019C	NUT LOCK 1/2-13 PLT	
22.	⊗ 815-085C	SPINDLE SGL 1.75X10.72	
	Ⓜ 201-003D	REPLACED BY 815-085C	
23.	816-011C	SEAL 2.56X1.625X.438 CR16289	
24.	822-018C	BEARING CONE LM-29749	
25.	822-019C	BEARING CUP LM-29710	
26.	200-003D	H5-A WHEEL HUB MACH 6-BOLT	
27.	⊗ 815-077C	HUB 6 BOLT 4 5/8 PILOT 3600 LB	Includes items 6, 7, 8, 10, 11, 20, 23, 24, 25
	Ⓜ 200-001S	REPLACED BY 815-077C	
28.	814-009C	TIRE 9.5L X 15-12 PLY-TUBELESS	
29.	814-015C	TUBE 9.5LX15-8 PLY W/CAL STEM	
30.	814-008C	WHEEL 8 X 15 X 6 BOLT	
31.	102-005K	PVT PL HITCH TRNSP WHL&TIRE	Includes items 28, 29, 30
32.	⊗ 815-079C	HUB AND SPINDLE ASSY 6 BOLT	Includes items 5, 8, 9, 10, 22 27
	Ⓜ 102-002K	REPLACED BY 815-079C	
33.	200-013D	H-06A W.H.6BT RPLBY 815-013C	Refer to item 12.
34.	152-215D	WHEEL REINFORCING RING	
35.	802-399C	HFS 1/2-20X1 1/2 GR5	
36.	805-246C	PIN COTTER 5/32 X 1 3/4 LG	

Legend: Ⓜ = 1st revision; ⊗ = 2nd revision; ⊕ = 3rd revision; ● = use up existing stock; ⊗ = not interchangeable; ⊗ Ⓜ = for example: revision 2 is not interchangeable w/revision 1

Coulters (S/N 9791Z-)

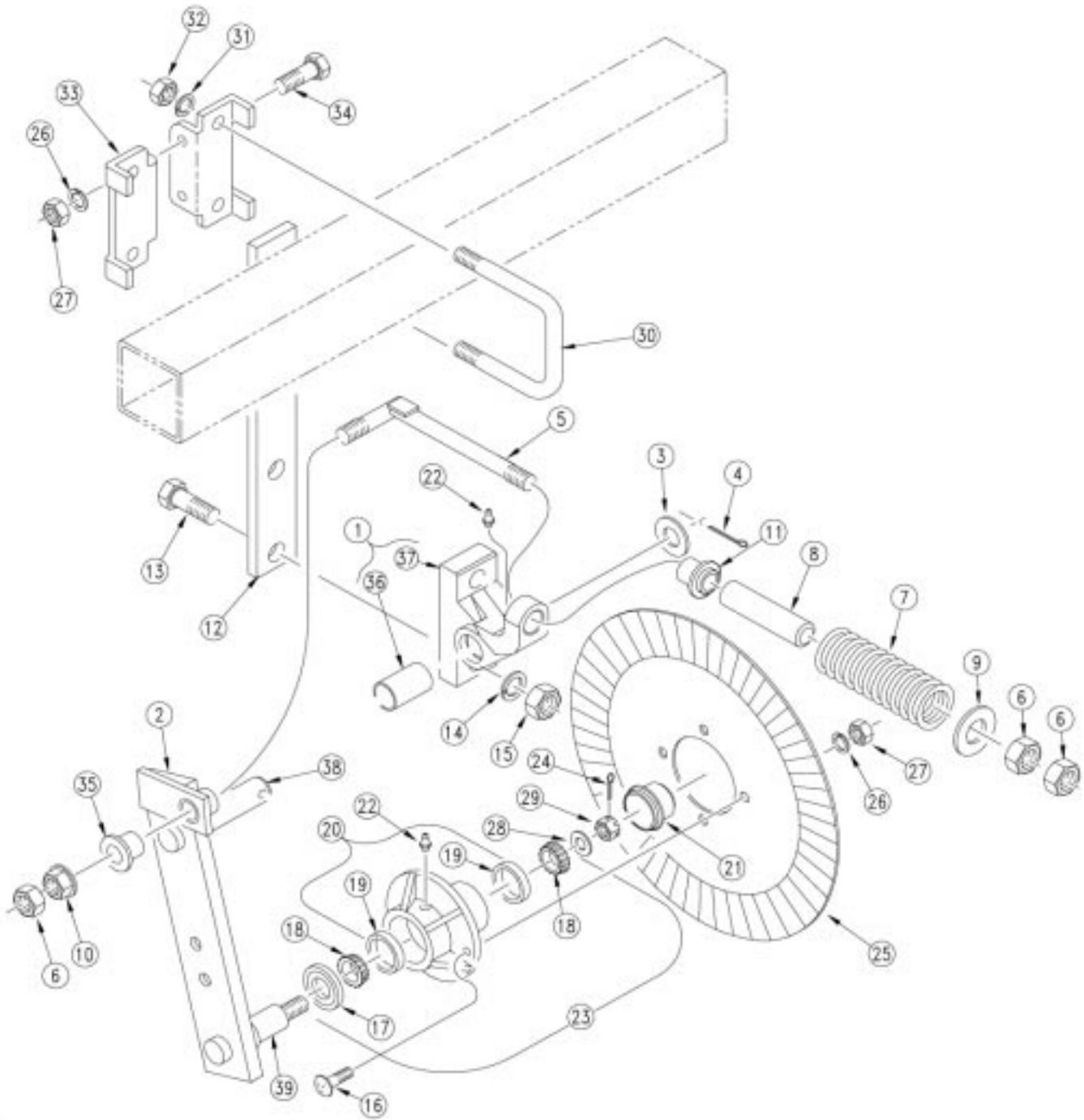

11932

Coulter (S/N 9791Z-)

Ref.	Part No.	Part Description	Comments
1.	149-962S	COULTR MOUNT, CASTNG ASSY	Includes items 36,37 Replaced 149-006D
2.	⊗ 149-181E	COULTER SWING ARM	Includes items 38,39
	● ① 149-928E	COULTER SWING ARM	
3.	804-039C	WASHER FLAT 1 1/4 SAE PLT	
4.	805-021C	PIN COTTER 1/4 X 2 PLT	
5.	204-075H	COULTER SPRING ROD WLDMT	
6.	803-048C	NUT HEX JAM 3/4-10 PLT	
7.	⊗ 149-559D	SPRING 2.25 O.D. X .5 COIL	
	① 807-074C	SPRING 2.25 OD X .5 COIL	
8.	204-107D	SPRING ROD SLEEVE 1 1/8 OD	
9.	⊗ 149-558D	COULTER SPRING WASHER	
	① 812-031C	CASTING COULTER SPRING WASHER	
10.	803-181C	NUT HEX FLANGE LOCK 3/4-10 PLT	
11.	817-029C	BUSHING COULTER CASTING	
12.	⊗ 204-269D	LONG COULT. SPRING BAR	
	① 807-138C	LONG COULTER SPRING BAR	
13.	802-103C	HHCS 7/8-9X2 3/4 GR5	
14.	804-037C	WASHER LOCK SPRING 7/8 PLT	
15.	803-049C	NUT HEX 7/8-9 PLT	
16.	802-214C	RHSNB 1/2-13X1 1/4 GR5	
17.	816-009C	OIL SEAL DOUBLE LIP	
18.	822-021C	BEARING CONE LM-67048	
19.	822-020C	BEARING CUP LM-67010	
20.	200-039V	COULTER HUB & CUP ASSY	
21.	200-001D	HUB GREASE CAP	
22.	800-001C	GREASE ZERK STRAIGHT 1/4-28	
23.	200-002S	COULTER HUB PACKAGE	Includes items 17, 18, 19, 20, 22
24.	805-017C	PIN COTTER 3/16 X 1 3/4 PLT	
25.	820-018C	COULTER BLADE FLUTED	
	820-116C	17 COULTER BLADE 5/8 WAVY	
	820-082C	17 COULTER BLADE 3/4 WAVY	
	820-156C	5/8 WAVY TURBO BLADE	
26.	804-015C	WASHER LOCK SPRING 1/2 PLT	
27.	803-020C	NUT HEX 1/2-13 PLT	
28.	804-055C	WASHER SPINDLE - 7/8	
29.	803-029C	NUT HEX SLOTTED 7/8-14 PLT	
30.	806-105C	U-BOLT 5/8-11 X 4 1/32 X 6	
31.	804-022C	WASHER LOCK SPRING 5/8 PLT	
32.	803-021C	NUT HEX 5/8-11 PLT	
33.	149-059D	COULTER CLAMP BAR	
34.	802-082C	HHCS 1/2-13X1 3/4 GR5	
35.	817-051C	SWING ARM BUSHING	
36.	890-389C	BUSHING 1.50ODX1.25IDX2.94	
37.	149-552D	MACH. MOUNT CASTING COULTER	
38.	149-004D	COULTER PIVOT SHAFT	
39.	201-006D	SPINDLE COULTER	

Legend: ● = 1st revision; ⊗ = 2nd revision; ⊕ = 3rd revision; ● = use up existing stock; ⊗ = not interchangeable; ⊗ ① = for example: revision 2 is not interchangeable w/revision 1

Coulters (S/N 9792Z+)

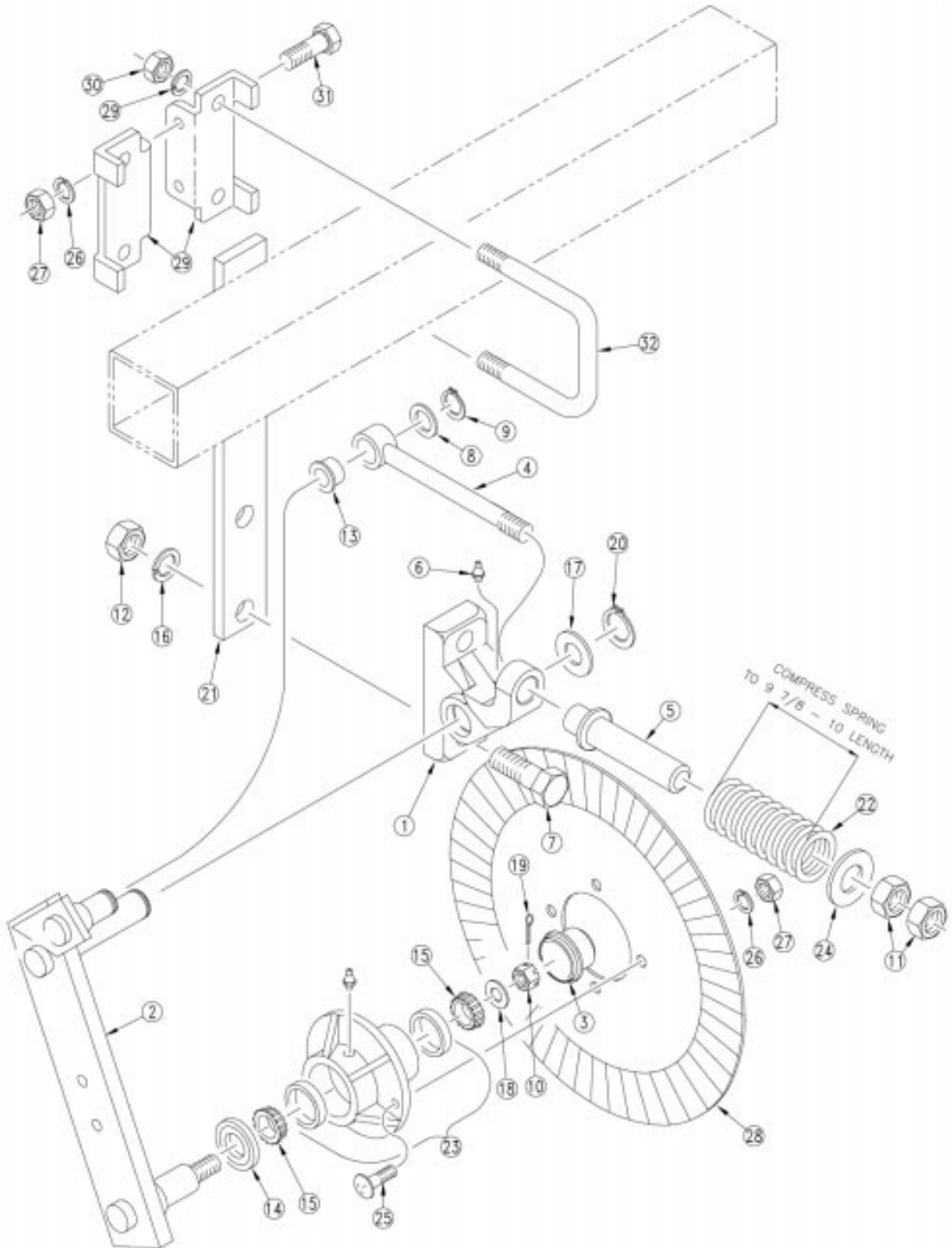

21713

Coulter (S/N 9792Z+)

Ref.	Part No.	Part Description	Comments
1.	249-050S	CLTR CASTING ASSY	
2.	249-051H	CLTR SWING ARM WLMT	
3.	200-001D	HUB GREASE CAP	
4.	802-718C	EYE BOLT 3/4-10X14 3/4 LG SP	
5.	805-331C	COULTER SPRING GUIDE TUBE	
6.	800-001C	GREASE ZERK STRAIGHT 1/4-28	
7.	802-103C	HHCS 7/8-9X2 3/4 GR5	
8.	804-156C	WASHER MACH 1 1/4X3/4X14GA	
9.	800-164C	SNAP RING 3/4 EXTERNAL HEAVY	
10.	803-029C	NUT HEX SLOTTED 7/8-14 PLT	
11.	803-048C	NUT HEX JAM 3/4-10 PLT	
12.	803-049C	NUT HEX 7/8-9 PLT	
13.	817-513C	BUSHING 1X3/4X1 1/8 FLG HD	
14.	816-009C	OIL SEAL DOUBLE LIP	
15.	822-021C	BEARING CONE LM-67048	
16.	804-037C	WASHER LOCK SPRING 7/8 PLT	
17.	804-165C	WASHER MACH 1 7/8X1 1/4X 14GA	
18.	804-055C	WASHER SPINDLE - 7/8	
19.	805-017C	PIN COTTER 3/16 X 1 3/4 PLT	
20.	800-177C	SNAP RING EXT 1 1/4 HEAVY	
21.	204-272D	COULT. SPRING BAR	
22.	149-559D	SPRING 2.25 O.D. X .5 COIL	
23.	200-039V	COULTER HUB & CUP ASSY	
24.	149-558D	COULTER SPRING WASHER	
25.	802-214C	RHSNB 1/2-13X1 1/4 GR5	
26.	804-015C	WASHER LOCK SPRING 1/2 PLT	
27.	803-020C	NUT HEX 1/2-13 PLT	
28.	820-018C	COULTER BLADE FLUTED	
	820-116C	17 COULTER BLADE 5/8 WAVY	
	820-082C	17 COULTER BLADE 3/4 WAVY	
	820-156C	5/8 WAVY TURBO BLADE	
29.	804-022C	WASHER LOCK SPRING 5/8 PLT	
30.	803-021C	NUT HEX 5/8-11 PLT	
31.	802-082C	HHCS 1/2-13X1 3/4 GR5	
32.	806-105C	U-BOLT 5/8-11 X 4 1/32 X 6	

Legend: ● = 1st revision; ● = 2nd revision; ● = 3rd revision; ● = use up existing stock; ⊗ = not interchangeable; ⊗ ① ● = for example: revision 2 is not interchangeable w/revision 1

Hydraulics

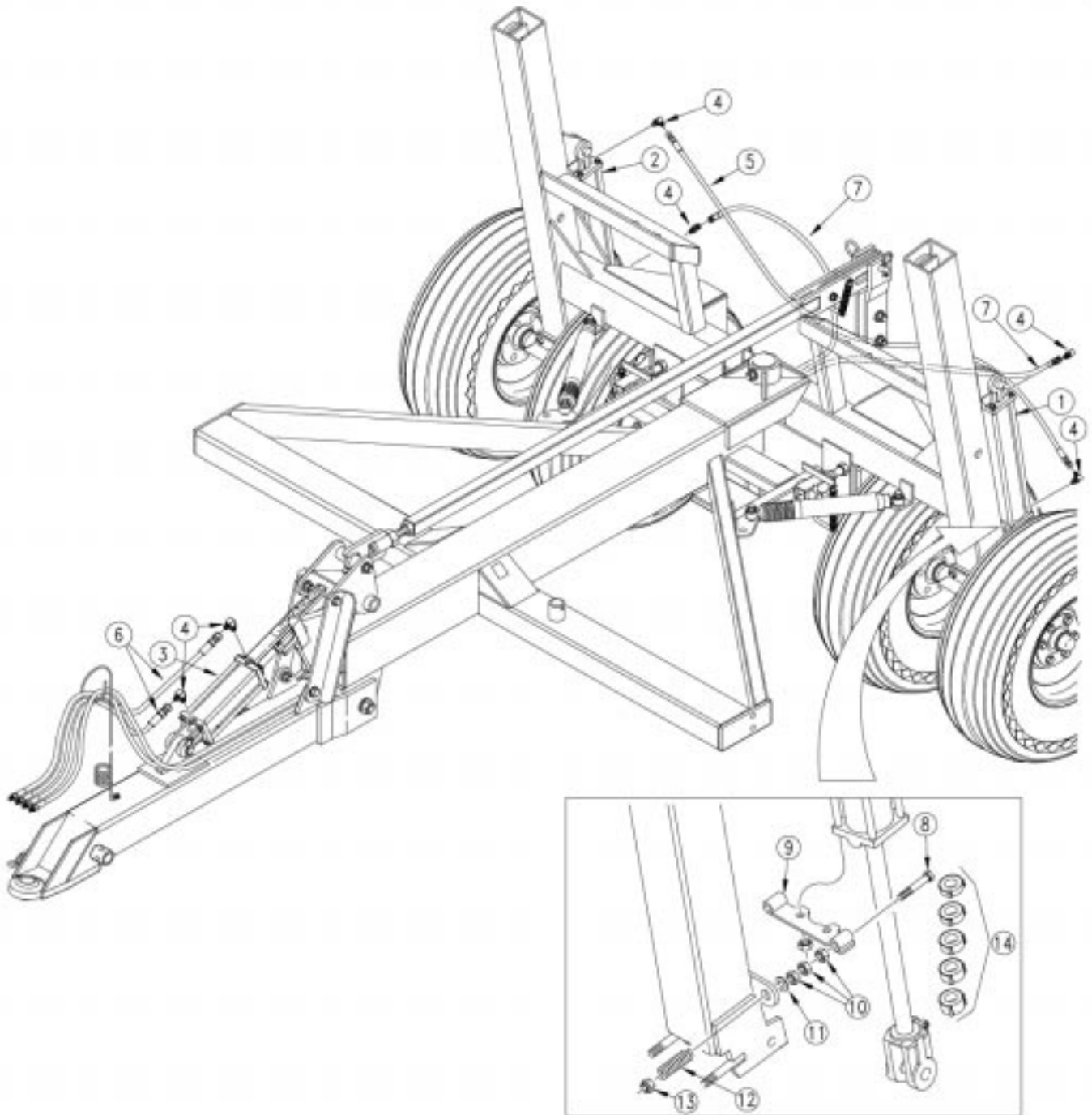

11978

Hydraulics

Ref.	Part No.	Part Description	Comments
1.	810-194C	CYL REP 4.25X24X1.5 ROD (TIE)	CPH w/Dry Fertilizer. Refer to page 14 for breakdown. 20' CPH Non-Fertilizer. Refer to page 10 for breakdown. 12' & 15' CPH Non-Fertilizer. Refer to page 8 for breakdown.
	810-192C	CYL REP 3.5X24X1.25 ROD (TIE)	
	810-191C	CYL REP 3.25X24X1.25 ROD (TIE)	
2.	810-193C	CYL REP 4X24X1.37 ROD (TIE)	CPH w/Dry Fertilizer. Refer to page 12 for breakdown. 20' CPH Non-Fertilizer. Refer to page 8 for breakdown. 12' & 15' CPH Non-Fertilizer. Refer to page 6 for breakdown.
	810-191C	CYL REP 3.25X24X1.25 ROD (TIE)	
	810-190C	CYL REP 3X24X1.25 ROD (TIE)	
3.	810-195C	CYL 3X8X1.25 ROD (TIE) NO PINS	Refer to page 4 for breakdown.
4.	811-063C	EL 3/4MJIC 3/4MORB	
5.	811-059C	HH1/2R2 080 3/4FJIC	
6.	811-272C	HH1/2R2 096 1/2MNPT 3/4FJIC	
7.	811-289C	HH1/2R2 250 1/2MNPT 3/4FJIC	
8.	802-380C	HHCS 1/2-13X5 1/2 FTHD	
9.	148-160H	3 CYL BRACE WLMT	
	148-154H	3 1/4 & 3 1/2 CYL BRACE WLMT	
	148-161H	4 CYL BRACE WLMT	
	148-162H	4 1/4 CYL BRACE WLMT	
10.	803-036C	NUT HEX JAM 1/2-13 PLT	
11.	804-017C	WASHER FLAT 1/2 USS PLT	
12.	807-078C	SPRING DIE 1OD X 1/2ID X 1 3/4	
13.	803-147C	NUT HEX NYLOCK 1/2-13	
14.	810-442C	MW STOP BUSH SET 1 1/4 SBS125	CPH Non-Fertilizer 2002+ CPH w/Dry Fertilizer 2002+
	810-443C	MW STOP BUSH SET 1 1/2 SBS150	

Legend: ● = 1st revision; ● = 2nd revision; ● = 3rd revision; ● = use up existing stock; ⊗ = not interchangeable; ⊗ ⊕ ● = for example: revision 2 is not interchangeable w/revision 1

Tongue Cylinder 810-195C

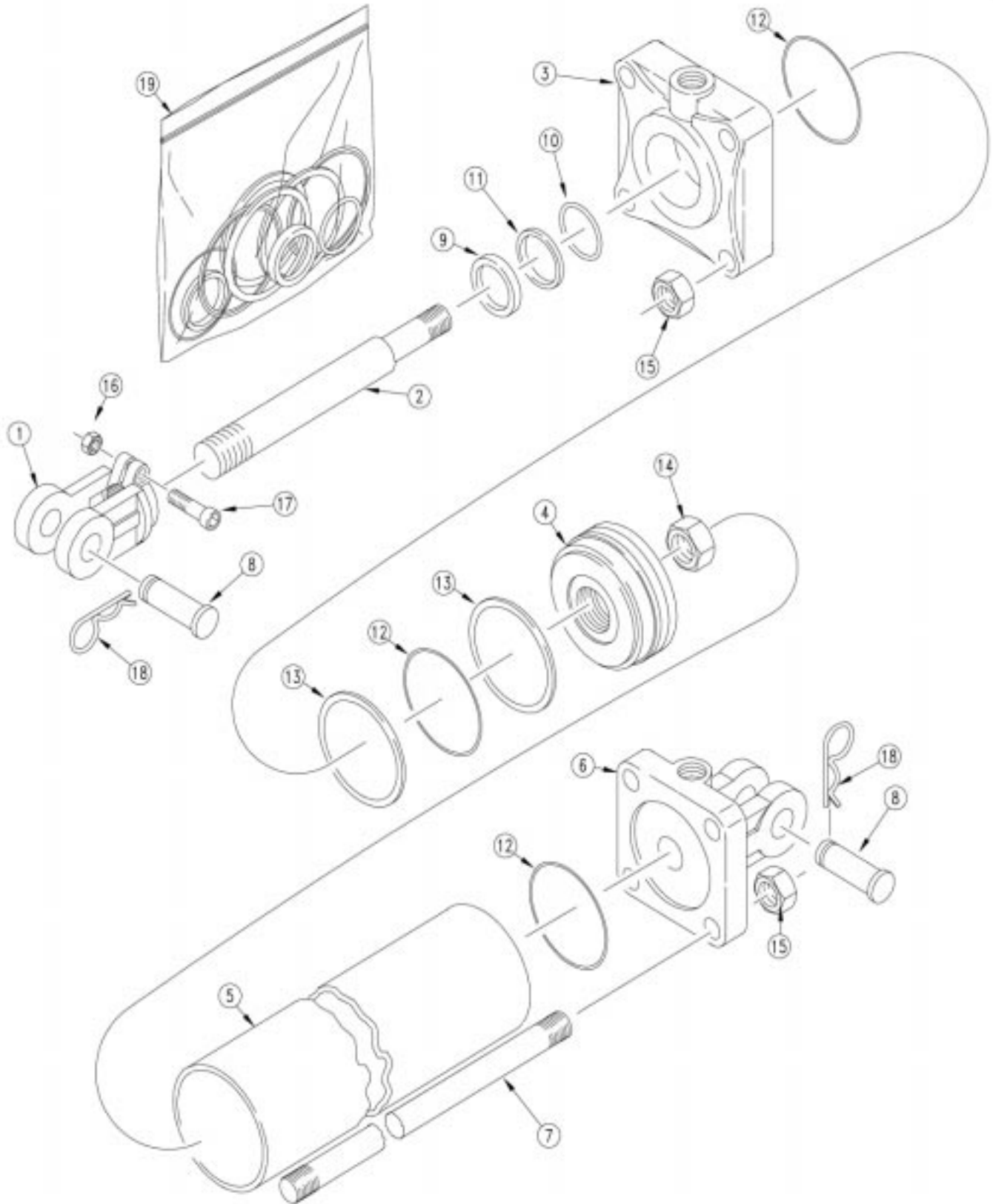

10035

Tongue Cylinder 810-195C

Ref.	Part No.	Part Description	Comments
1.	1M7016	CLEVIS ROD MIDWAY	
2.	2M4416	MW ROD 1-1/4 DIA X 8 STROKE	
3.	3R1412	MW HEAD	
4.	4M4104	MW PISTON 3 DIA.	
5.	5M4116	MW TUBE 3 X 8 CYLINDER	
6.	6R1164	MW BASE	
7.	7M4316	MW TIE ROD 3 X 8 CYLINDER	
8.	2A0208	MW CLEVIS PIN	
9.		WIPER SEAL	Only available in item 19.
10.		O-RING	Only available in item 19.
11.		BACK-UP	Only available in item 19.
12.		O-RING	Only available in item 19.
13.		BACK-UP	Only available in item 19.
14.	2A0024	MW PISTON NUT 1-14	
15.	2A0014	MW TIE ROD NUT	
16.	2A0012	MW NUT CLEVIS & TIE ROD	
17.	2A0006	MW CAPSCREW	
18.	2A0132	MW PIN CLIP	
19.	810-015C	CYL SEAL KIT 3 X 7 MW 5A4104	

Legend: ● = 1st revision; ● = 2nd revision; ● = 3rd revision; ● = use up existing stock; ⊗ = not interchangeable; ⊗ ① ● = for example: revision 2 is not interchangeable w/revision 1

Rephasing Transport Cylinder 810-190C

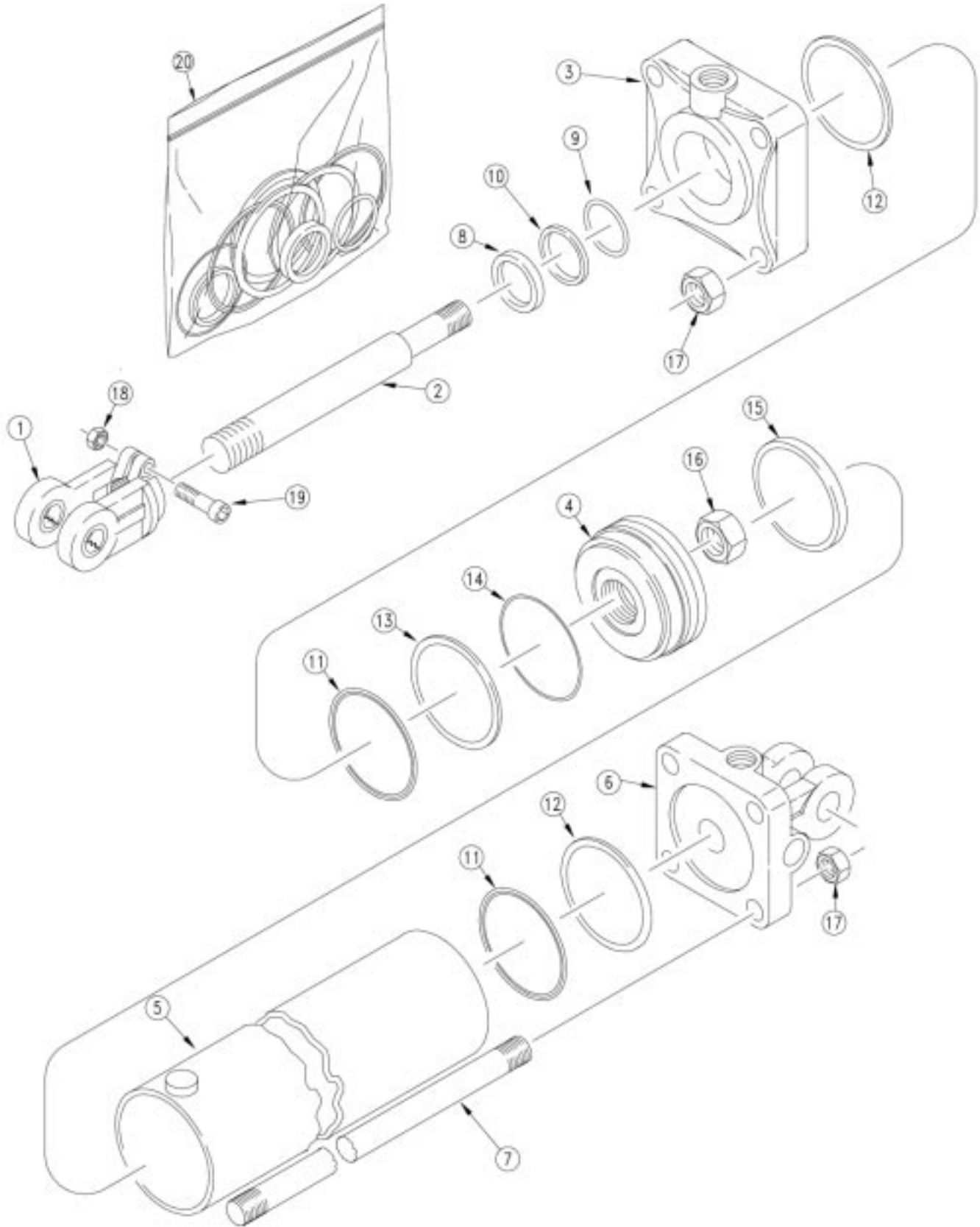

11715

Rephasing Transport Cylinder 810-190C

Ref.	Part No.	Part Description	Comments
1.	1M7016	CLEVIS ROD MIDWAY	
2.	2M4434	MW ROD	
3.	3R1412	MW HEAD	
4.	4R1106	PISTON MIDWAY	
5.	5R1132	MW TUBE	
6.	6R1164	MW BASE	
7.	7M4412	MW TIE ROD	
8.		WIPER SEAL	Only available in item 20.
9.		O-RING	Only available in item 20.
10.		BACK-UP	Only available in item 20.
11.		O-RING	Only available in item 20.
12.		BACK-UP	Only available in item 20.
13.		TEFLON SEAL	Only available in item 20.
14.		LOADER O-RING	Only available in item 20.
15.		WEAR RING	Only available in item 20.
16.	2A0024	MW PISTON NUT 1-14	
17.	2A0014	MW TIE ROD NUT	
18.	2A0012	MW NUT CLEVIS & TIE ROD	
19.	2A0006	MW CAPSCREW	
20.	810-211C	SEAL KIT MW 3 RPHCYL 4A1104	

Legend: ① = 1st revision; ② = 2nd revision; ③ = 3rd revision; ● = use up existing stock; ⊗ = not interchangeable; ⊗ ① ② = for example: revision 2 is not interchangeable w/revision 1

Transport Cylinder 810-191C

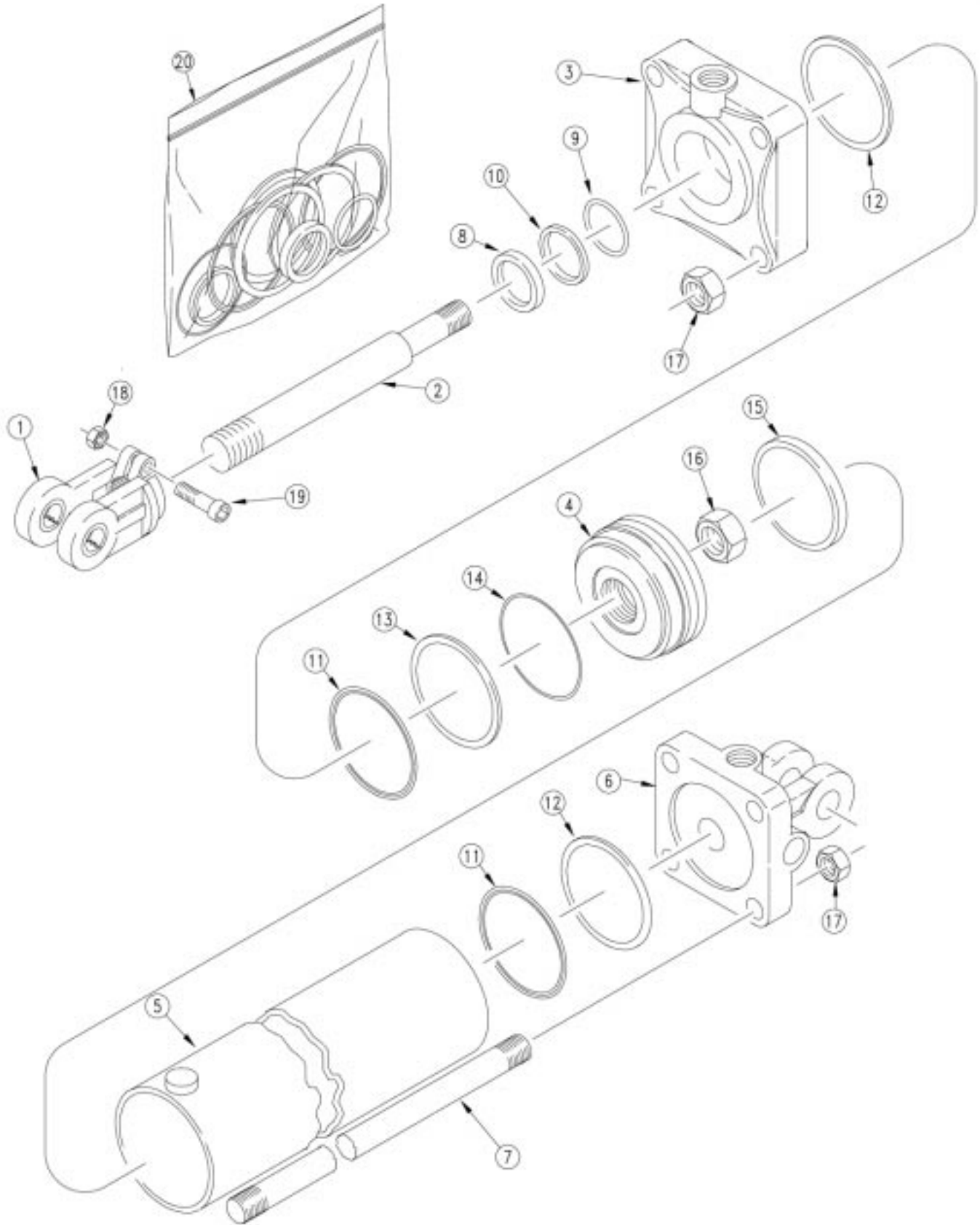

11715

Transport Cylinder 810-191C

Ref.	Part No.	Part Description	Comments
1.	1M7016	CLEVIS ROD MIDWAY	
2.	2M5434	MW ROD	
3.	3R2412	MW HEAD	
4.	4R2106	PISTON MIDWAY	
5.	5R2132	MW TUBE	
6.	6R2164	BASE MIDWAY	
7.	7M5412	MW TIE ROD	
8.		WIPER SEAL	Only available in item 20.
9.		O-RING	Only available in item 20.
10.		BACK-UP	Only available in item 20.
11.		O-RING	Only available in item 20.
12.		BACK-UP	Only available in item 20.
13.		TEFLON SEAL	Only available in item 20.
14.		LOADER O-RING	Only available in item 20.
15.		WEAR RING	Only available in item 20.
16.	2A0024	MW PISTON NUT 1-14	
17.	2A0016	MW TIE ROD NUT	
18.	2A0012	MW NUT CLEVIS & TIE ROD	
19.	2A0006	MW CAPSCREW	
20.	810-173C	SEAL KIT MW 3.25 RPHCYL 4A2104	

Legend: ① = 1st revision; ② = 2nd revision; ③ = 3rd revision; ● = use up existing stock; ⊗ = not interchangeable; ⊗ ① ② = for example: revision 2 is not interchangeable w/revision 1

Rephasing Transport Cylinder 810-192C

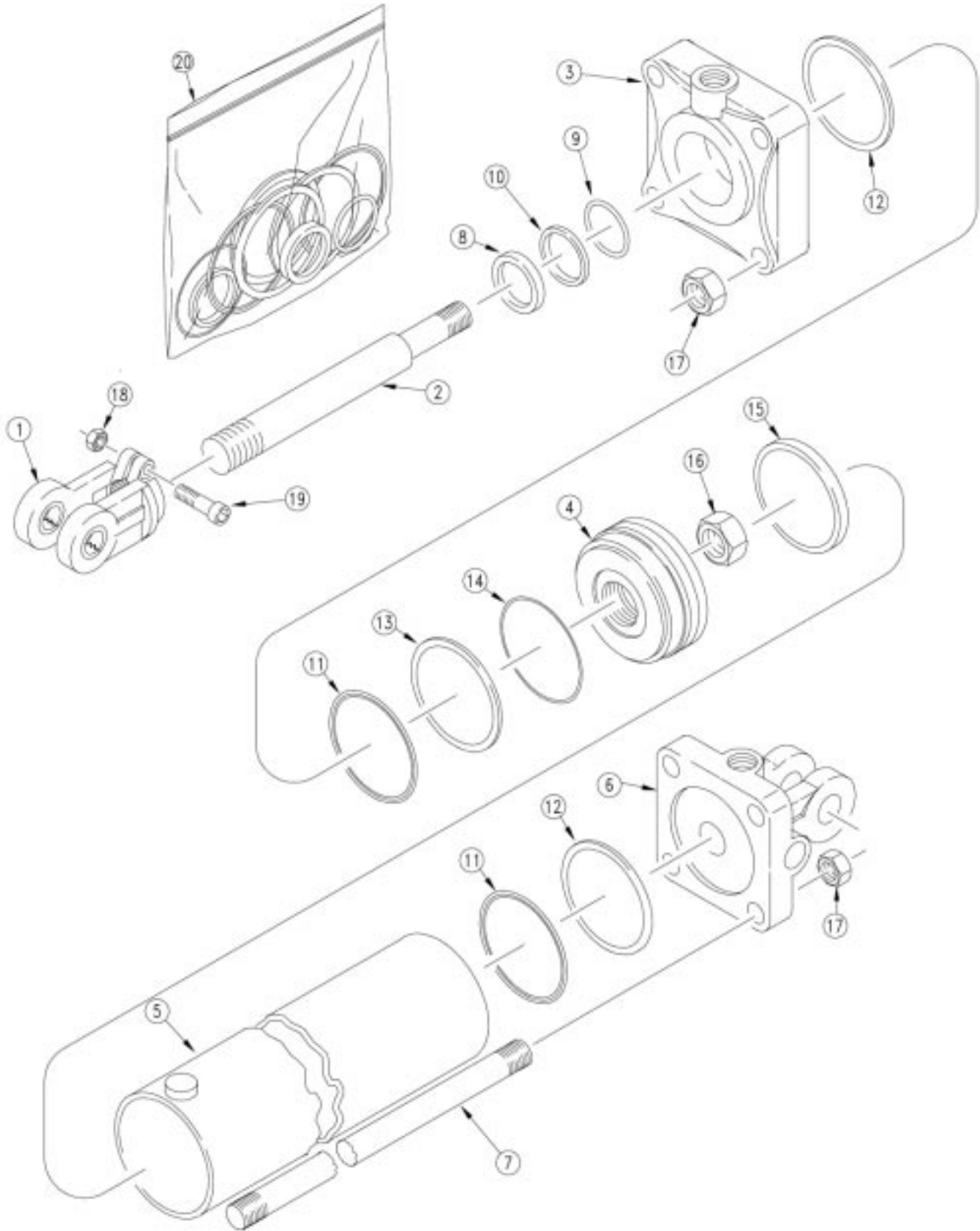

11715

Rephasing Transport Cylinder 810-192C

Ref.	Part No.	Part Description	Comments
21.	1M7016	CLEVIS ROD MIDWAY	
22.	2M5434	MW ROD	
23.	3R3412	MW HEAD	
24.	4R3106	PISTON MIDWAY	
25.	5R3132	MW TUBE	
26.	6R3164	BASE MIDWAY	
27.	7M5412	MW TIE ROD	
28.		WIPER SEAL	Only available in item 20.
29.		O-RING	Only available in item 20.
30.		BACK-UP	Only available in item 20.
31.		O-RING	Only available in item 20.
32.		BACK-UP	Only available in item 20.
33.		TEFLON SEAL	Only available in item 20.
34.		LOADER O-RING	Only available in item 20.
35.		WEAR RING	Only available in item 20.
36.	2A0024	MW PISTON NUT 1-14	
37.	2A0016	MW TIE ROD NUT	
38.	2A0012	MW NUT CLEVIS & TIE ROD	
39.	2A0006	MW CAPSCREW	
40.	810-174C	SEAL KIT MW 3.5 RPHCYL 4A3104	

Legend: ① = 1st revision; ② = 2nd revision; ③ = 3rd revision; ● = use up existing stock; ⊗ = not interchangeable; ⊗ ① ② = for example: revision 2 is not interchangeable w/revision 1

Rephasing Transport Cylinder 810-193C

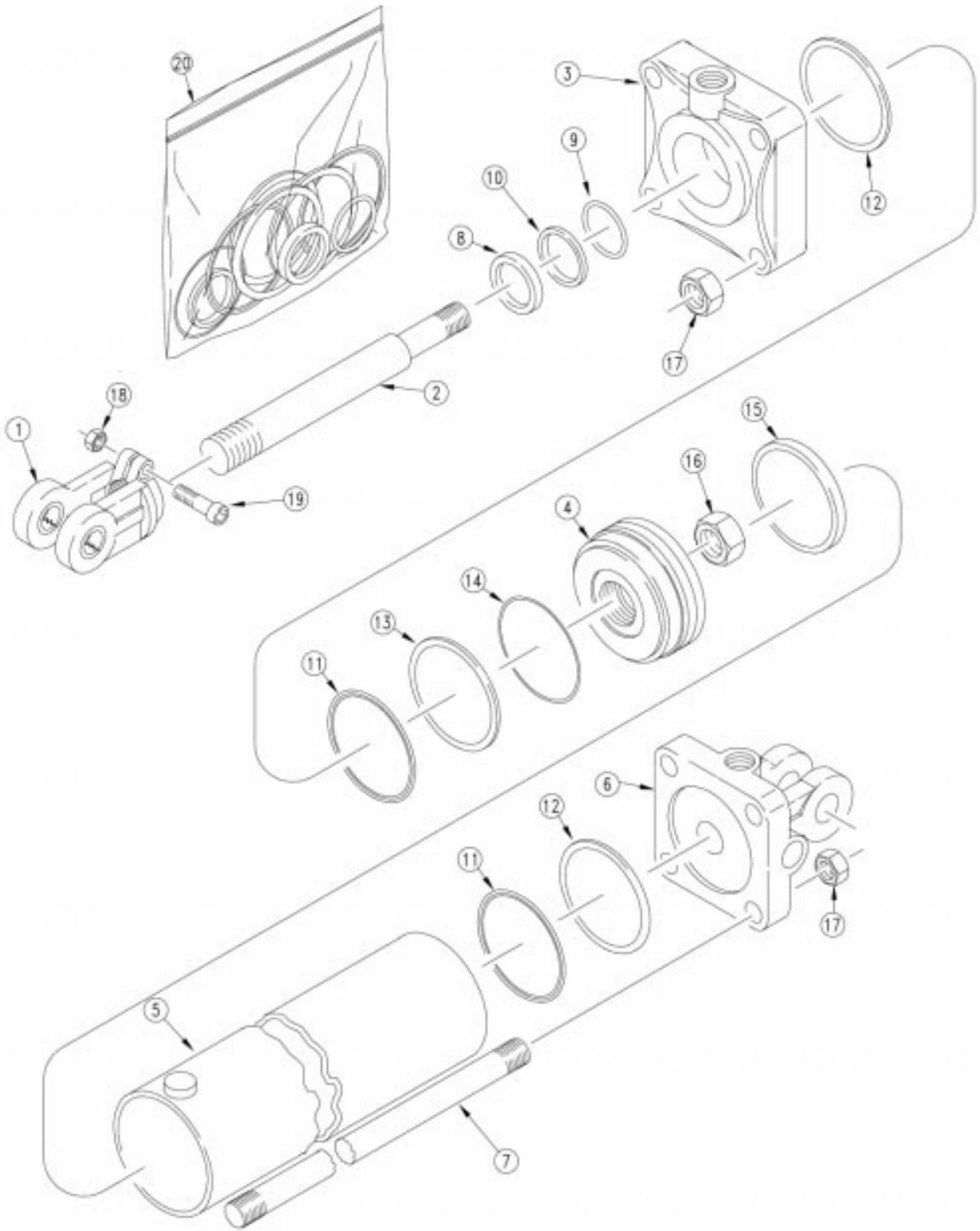

11715

Rephasing Transport Cylinder 810-193C

Ref.	Part No.	Part Description	Comments
1.	1M7016	CLEVIS ROD MIDWAY	
2.	2M6832	MW ROD	
3.	3R5812	MW HEAD	
4.	4R5108	PISTON MIDWAY	
5.	5R5132	MW TUBE	
6.	6R5164	BASE MIDWAY	
7.	7M6426	MW TIE ROD	
8.		WIPER SEAL	Only available in item 20.
9.		O-RING	Only available in item 20.
10.		BACK-UP	Only available in item 20.
11.		O-RING	Only available in item 20.
12.		BACK-UP	Only available in item 20.
13.		TEFLON SEAL	Only available in item 20.
14.		LOADER O-RING	Only available in item 20.
15.		WEAR RING	Only available in item 20.
16.	2A0024	MW PISTON NUT 1-14	
17.	2A0018	MW TIE ROD NUT	
18.	2A0012	MW NUT CLEVIS & TIE ROD	
19.	2A0006	MW CAPSCREW	
20.	810-151C	SEAL KIT MW 4 RPH CYL 4A5103	

Legend: ● = 1st revision; ● = 2nd revision; ● = 3rd revision; ● = use up existing stock; ⊗ = not interchangeable; ⊗ ① ● = for example: revision 2 is not interchangeable w/revision 1

Rephasing Transport Cylinder 810-194C

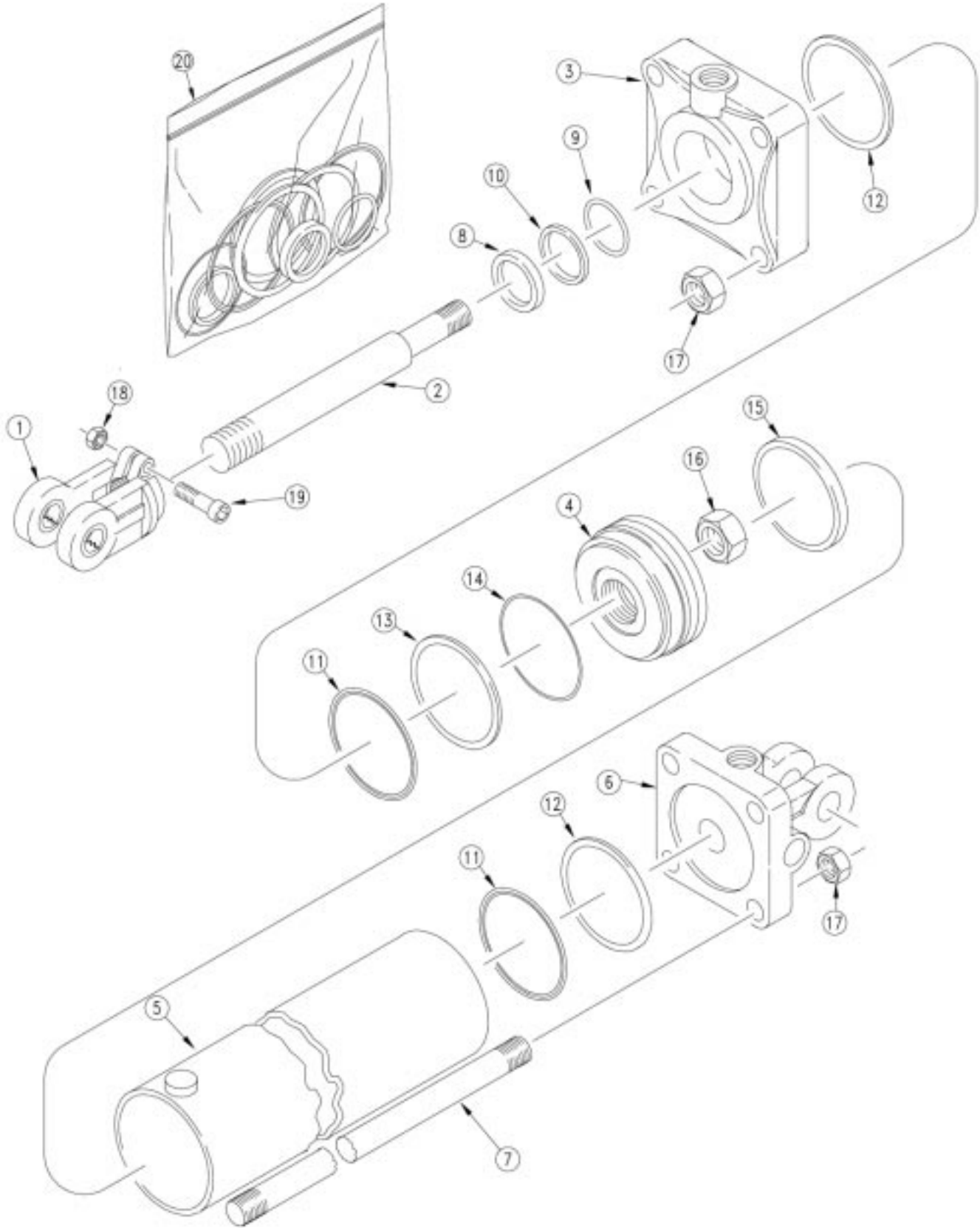

11715

Rephasing Transport Cylinder 810-194C

Ref.	Part No.	Part Description	Comments
1.	1M7016	CLEVIS ROD MIDWAY	
2.	2M7532	MW ROD	
3.	3R6912	HEAD MIDWAY	
4.	4R6108	PISTON MIDWAY	
5.	5R6132	MW TUBE	
6.	6R6164	BASE MIDWAY	
7.	7M7426	MW TIE ROD	
8.		WIPER SEAL	Only available in item 20.
9.		O-RING	Only available in item 20.
10.		BACK-UP	Only available in item 20.
11.		O-RING	Only available in item 20.
12.		BACK-UP	Only available in item 20.
13.		TEFLON SEAL	Only available in item 20.
14.		LOADER O-RING	Only available in item 20.
15.		WEAR RING	Only available in item 20.
16.	2A0024	MW PISTON NUT 1-14	
17.	2A0019	TIE ROD NUT MIDWAY	
18.	2A0012	MW NUT CLEVIS & TIE ROD	
19.	2A0006	MW CAPSCREW	
20.	810-144C	SEAL KIT MW 4.25 RPHCYL 4A6104	

Legend: ● = 1st revision; ● = 2nd revision; ● = 3rd revision; ● = use up existing stock; ⊗ = not interchangeable; ⊗ ① ● = for example: revision 2 is not interchangeable w/revision 1

Coulter Depth Control Hydraulics

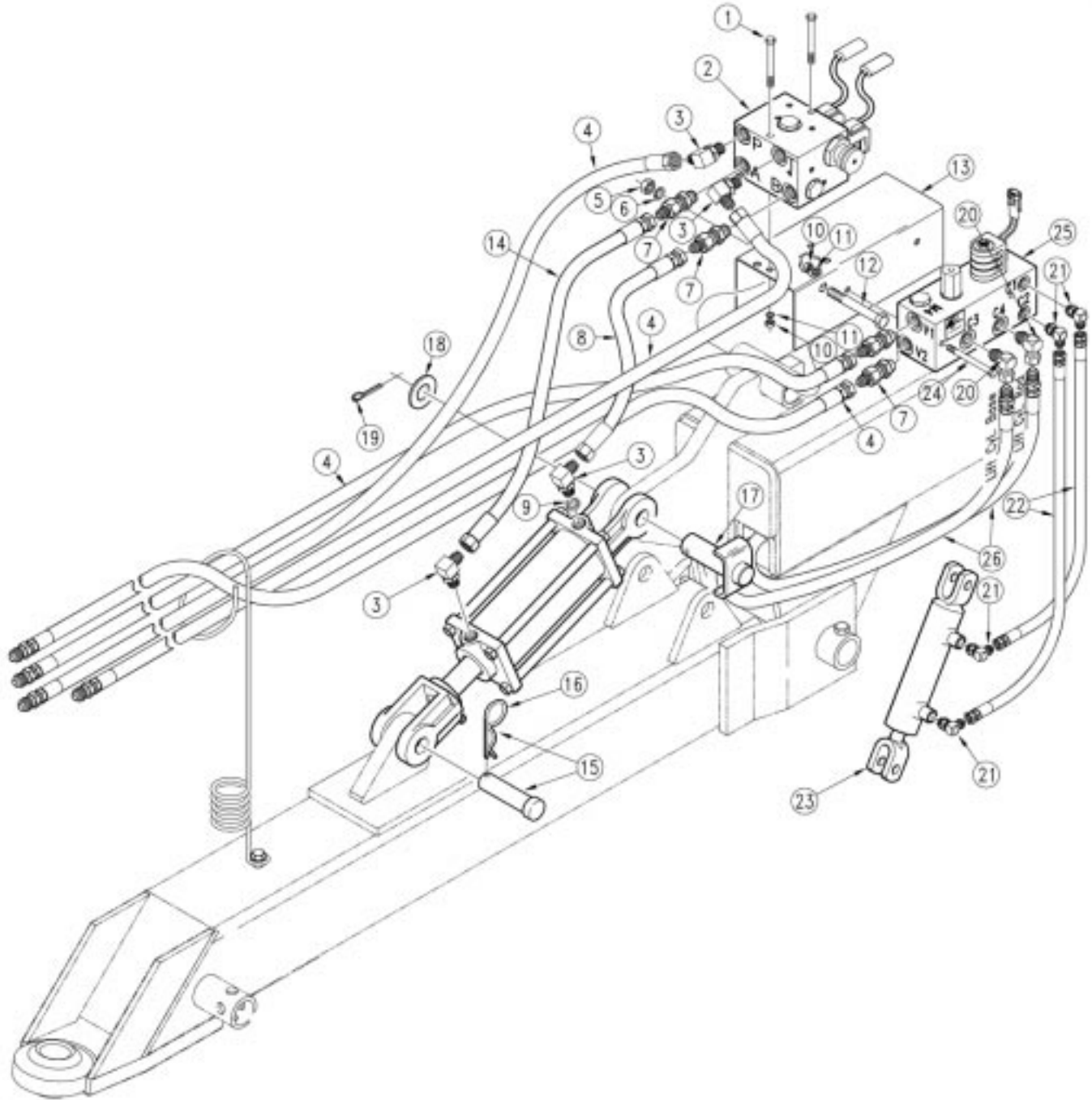

13482

Coulter Depth Control Hydraulics

Ref.	Part No.	Part Description	Comments
1.	802-279C	HHCS 5/16-18X4 GR5	
2.	810-214C	VALVE ELECTRONIC DEPTH CONTROL	Refer to page 14 for breakdown.
3.	811-063C	EL 3/4MJIC 3/4MORB	
4.	811-383C	HH1/2R1 122 1/2MNPT 3/4FJIC	
5.	803-020C	NUT HEX 1/2-13 PLT	
6.	804-015C	WASHER LOCK SPRING 1/2 PLT	
7.	811-088C	AD 3/4MORB 3/4MJIC	
8.	811-331C	HH1/2R2 020 3/4FJIC	
9.	811-172C	ORPL 1/16 3/4	
10.	803-008C	NUT HEX 5/16-18 PLT	
11.	804-009C	WASHER LOCK SPRING 5/16 PLT	
12.	802-046C	HHCS 1/2-13X5 1/2 GR5	
13.	148-415D	HYDRAULIC VALVE MOUNT	
14.	811-340C	HH1/2R2 030 3/4FJIC	
15.	805-004C	PIN CLEVIS 1 X 2 3/4 USABLE LG	
16.	805-010C	PIN HAIR COTTER .094	
17.	148-283H	COULTER COMMAND CYLINDER PIN	
18.	804-029C	WASHER FLAT 1 SAE	
19.	805-021C	PIN COTTER 1/4 X 2 PLT	
20.	811-280C	EL 1/2FNPT 3/4MORB	
21.	811-065C	EL 9/16MJIC 9/16MORB	
22.	811-443C	HH1/4R2 036 9/16FJIC	
23.	810-259C	CYL 1.50X4.0X.75 WELD 1 PIN	
24.	802-333C	HHCS 5/16-18X3 1/2 GR5	
25.	810-262C	CLT CMD LIFT CIRCUIT MANIFOLD	Refer to page 12 for breakdown.

Legend: ● = 1st revision; ● = 2nd revision; ● = 3rd revision; ● = use up existing stock; ⊗ = not interchangeable; ⊗ ① ● = for example: revision 2 is not interchangeable w/revision 1

Coulter Command Electronics

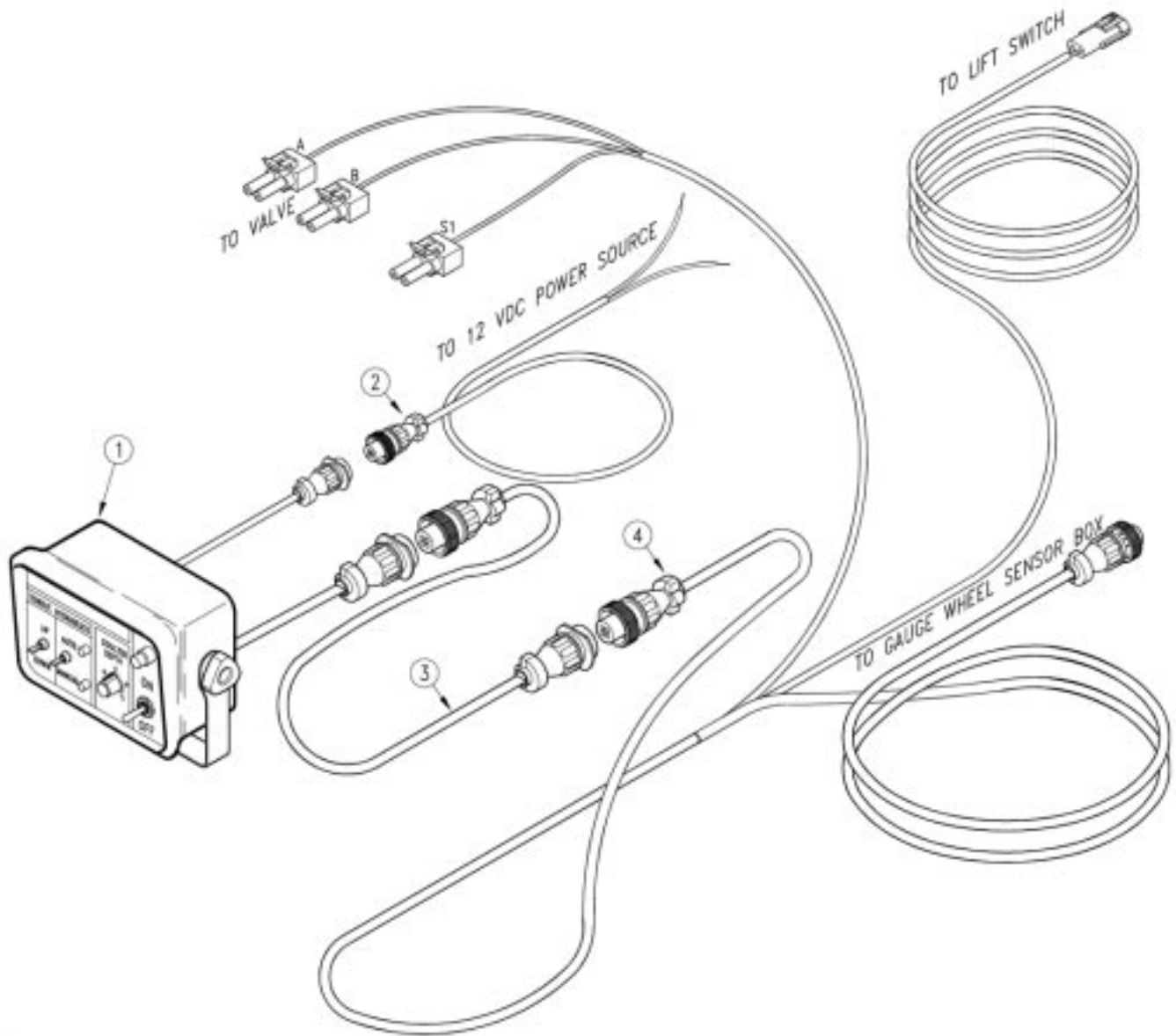

12623

Coulter Command Electronics

Ref.	Part No.	Part Description	Comments
1.	823-103C	COULTER CMD CONTROL BOX	
2.	823-110C	COULTER CMD POWER CORD	
3.	823-108C	COULTER CMD CONTROL BOX CABLE	
4.	823-104C	COULTER CMD WIRE HARNESS	

Legend: ① = 1st revision; ② = 2nd revision; ③ = 3rd revision; ● = use up existing stock; ⊗ = not interchangeable; ⊗ ① ② = for example: revision 2 is not interchangeable w/revision 1

Coultter Command Gauge Wheel

Ref.	Part No.	Part Description	Comments
1.	823-105C	COULTER CMD GW SENSOR BOX	
2.	803-068C	NUT HEX FLANGE 3/8-16 PLT	
3.	804-012C	WASHER FLAT 3/8 SAE PLT	
4.	803-008C	NUT HEX 5/16-18 PLT	
5.	804-009C	WASHER LOCK SPRING 5/16 PLT	
6.	148-507D	CPH CLTR CMD GW SENSOR MOUNT	
7.	804-004C	WASHER INTERNAL STAR #10 PLT	
8.	801-051C	CRPHMS 10-24X7/16	
9.	802-091C	HHCS 1/2-13X1 1/2 GR5	
10.	800-148C	CABLE TIE MOUNT	
11.	800-149C	CABLE TIE 6 LONG REL.	
12.	822-041C	FLANGETTE 47 MST	
13.	822-040C	BEARING 3/4BORE 47MM SPHERE OD	
14.	802-092C	RHSNB 5/16-18X3/4 GR5	
15.	148-382D	CPH GAUGE WHEEL MOUNT PIN	
16.	806-105C	U-BOLT 5/8-11 X 4 1/32 X 6	
17.	804-022C	WASHER LOCK SPRING 5/8 PLT	
18.	803-021C	NUT HEX 5/8-11 PLT	
19.	148-199H	CPH GAUGE WHEEL MOUNT WELDMNT	
20.	804-015C	WASHER LOCK SPRING 1/2 PLT	
21.	803-020C	NUT HEX 1/2-13 PLT	
22.	802-128C	HHCS 1/2-13X2 GR5	
23.	148-381D	CPH GAUGE WHEEL MOUNT EAR	
24.	148-197H	GAUGE WHEEL SPRING WELDMNT	
25.	817-129C	FLNG BUSHING 1 1/8 X 1 X 3/4	
26.	805-146C	PIN ROLL 1/4 X 2 LG PL	
27.	817-084C	PARALLEL ARM PIVOT BUSHING	
28.	148-413D	G.W. SPRING SPACER TUBE	
29.	822-091C	BEARING CONE 15123	
30.	816-098C	SEAL 1 3/8 ID X 2.441 OD X.313	
31.	802-041C	HHCS 1/2-13X3 1/2 GR5	
32.	804-109C	WASHER FLAT #6 SAE PLT	
33.	804-050C	WASHER LOCK #6 SS	
34.	801-017C	SCREW PAN HD 6-32 X 1/2 SS	
35.	823-106C	COULTER CMD SPEED SENSOR	
36.	148-177H	COULTER COMMAND G.W. ARM WLMT	
37.	802-104C	BOLT WHEEL 1/2-20X1 90-DEG	
38.	816-035C	VALVE STEM TR415X.625X1 1/4 LG	
39.	814-115C	TIRE 5.00-15 SL 4 PLY	
40.	814-116C	WHEEL 15 DIA X 1/2 WIDEX4 BLT	
41.	148-246S	5SL-15 SL 4 PLY WHL & TIRE ASY	
42.	148-426D	SPEED SENSOR PLATE	
43.	200-001D	HUB GREASE CAP	
44.	805-016C	PIN COTTER 3/16 X 1 1/4 PLT	
45.	803-029C	NUT HEX SLOTTED 7/8-14 PLT	
46.	804-055C	WASHER SPINDLE - 7/8	
47.	⊕ 815-093C	HUB 4 BOLT WHL W/CUPS & ZERK	
	Ⓜ 312-151S	4BLT WHLHUB ASSY(RPBY 815-093C	
48.	822-092C	BEARING CUP 15245	
49.	⊕ 815-093C	HUB 4 BOLT WHL W/CUPS & ZERK	
	Ⓜ 312-106D	4 BOLT HUB (RPBY 815-091C)	
50.	800-001C	GREASE ZERK STRAIGHT 1/4-28	
51.	816-193C	COL CMMD GW SENSOR BOX GASKET	
52.	04003013	CLEVIS PIN	
53.	805-067C	PIN COTTER 1/8 X 3/4	
54.	810-259C	CYL 1.50X4.0X.75 WELD 1 PIN	
55.	804-017C	WASHER FLAT 1/2 USS PLT	
56.	805-128C	PIN CLEVIS 1/2 X 2 3/4	

Legend: Ⓜ = 1st revision; ⊕ = 2nd revision; ⊕ = 3rd revision; ● = use up existing stock; ⊗ = not interchangeable; ⊗ ⊕ ⊕ = for example: revision 2 is not interchangeable w/revision 1

Top Link (Jan 1, 2001-)

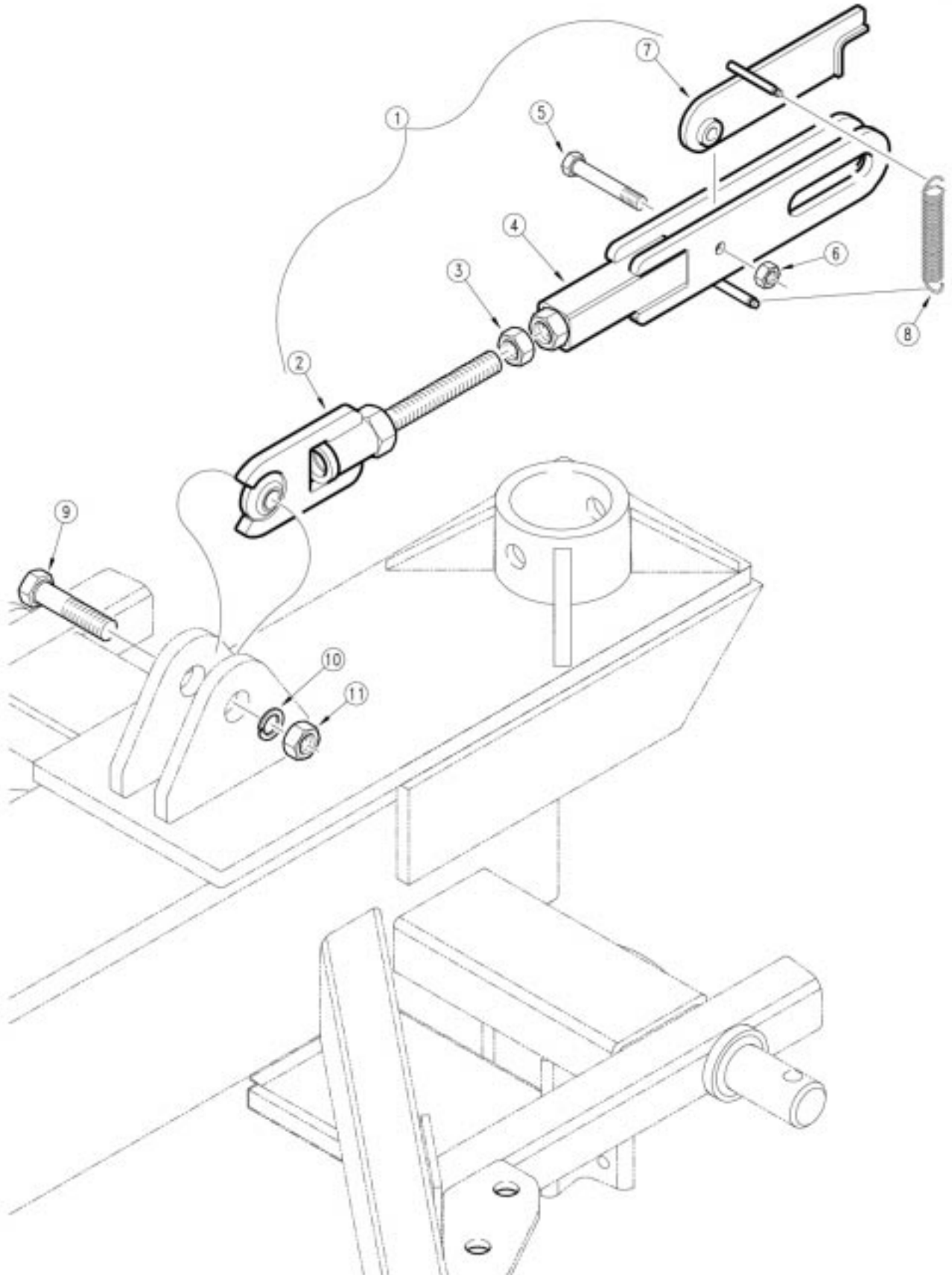

12601

Top Link (Jan 1, 2001-)

Ref.	Part No.	Part Description	Comments
1.	148-217V	94 ALL SEEDS TOP LINK TUBE ASY	Includes items 2 thru 7.
2.	148-085H	LEVEL LINK ADJUSTER	
3.	803-034C	NUT HEX 1 1/4-7 PLT	
4.	148-198H	TOP LINK WLMT	
5.	802-059C	HHCS 5/8-11X3 GR5	
6.	803-024C	NUT LOCK 5/8-11 PLT	
7.	148-084H	LEVEL LINK LOCK PLATE	
8.	807-063C	SPRING, LEVEL LINK LOCK	
9.	802-073C	HHCS 1-8X4 GR5	
10.	804-027C	WASHER LOCK SPRING 1 PLT	
11.	803-031C	NUT HEX 1-8 PLT	

Legend: ● = 1st revision; ● = 2nd revision; ● = 3rd revision; ● = use up existing stock; ⊗ = not interchangeable; ⊗ ① ● = for example: revision 2 is not interchangeable w/revision 1

Coulter Command Switch Mount

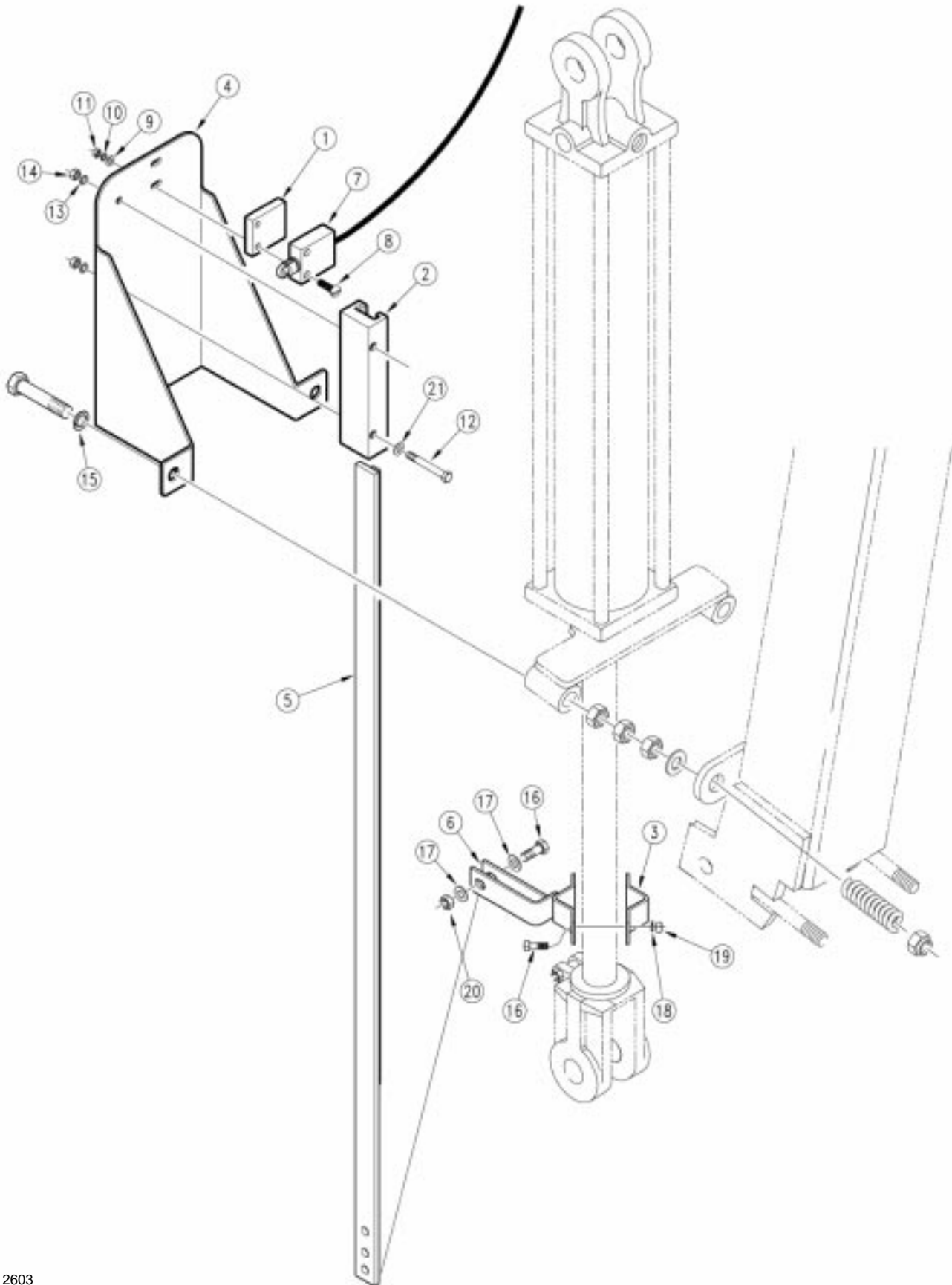

12603

Coulter Command Switch Mount

Ref.	Part No.	Part Description	Comments
1.	148-500D	CPH CLTR CMD SWITCH SPACER PLT	
2.	817-170C	CPH CLTR CMD SWITCH GUIDE BLK	
3.	148-510D	CPH CLTR CMD CYL ROD CLAMP	
4.	148-502D	CPH COULTER CMD SWITCH MOUNT	
5.	148-247H	CPH CLTR CMD PUSH ROD WLMT	
6.	148-264H	CPH CLTR CMD CYL ROD CLAMP	
7.	823-107C	COULTER CMD AS LIFT SWITCH	
8.	801-085C	SCR RD HD 10-24X1 1/2 LG PLT	
9.	804-046C	WASHER FLAT #10 SAE PLT	
10.	804-054C	WASHER LOCK #10	
11.	803-001C	NUT HEX 10-24 PLT	
12.	802-152C	HHCS 1/4-20X2 GR5	
13.	804-006C	WASHER LOCK SPRING 1/4 PLT	
14.	803-006C	NUT HEX 1/4-20 PLT	
15.	804-015C	WASHER LOCK SPRING 1/2 PLT	
16.	802-010C	HHCS 5/16-18X1 1/4 GR5	
17.	804-010C	WASHER FLAT 5/16 USS PLT	
18.	804-009C	WASHER LOCK SPRING 5/16 PLT	
19.	803-008C	NUT HEX 5/16-18 PLT	
20.	803-084C	NUT HEX NYLOCK 5/16-18 PLT	
21.	804-007C	WASHER FLAT 1/4 SAE PLT	

Legend: ● = 1st revision; ● = 2nd revision; ● = 3rd revision; ● = use up existing stock; ⊗ = not interchangeable; ⊗ ① ● = for example: revision 2 is not interchangeable w/revision 1

Lift Circuit Manifold (810-262C)

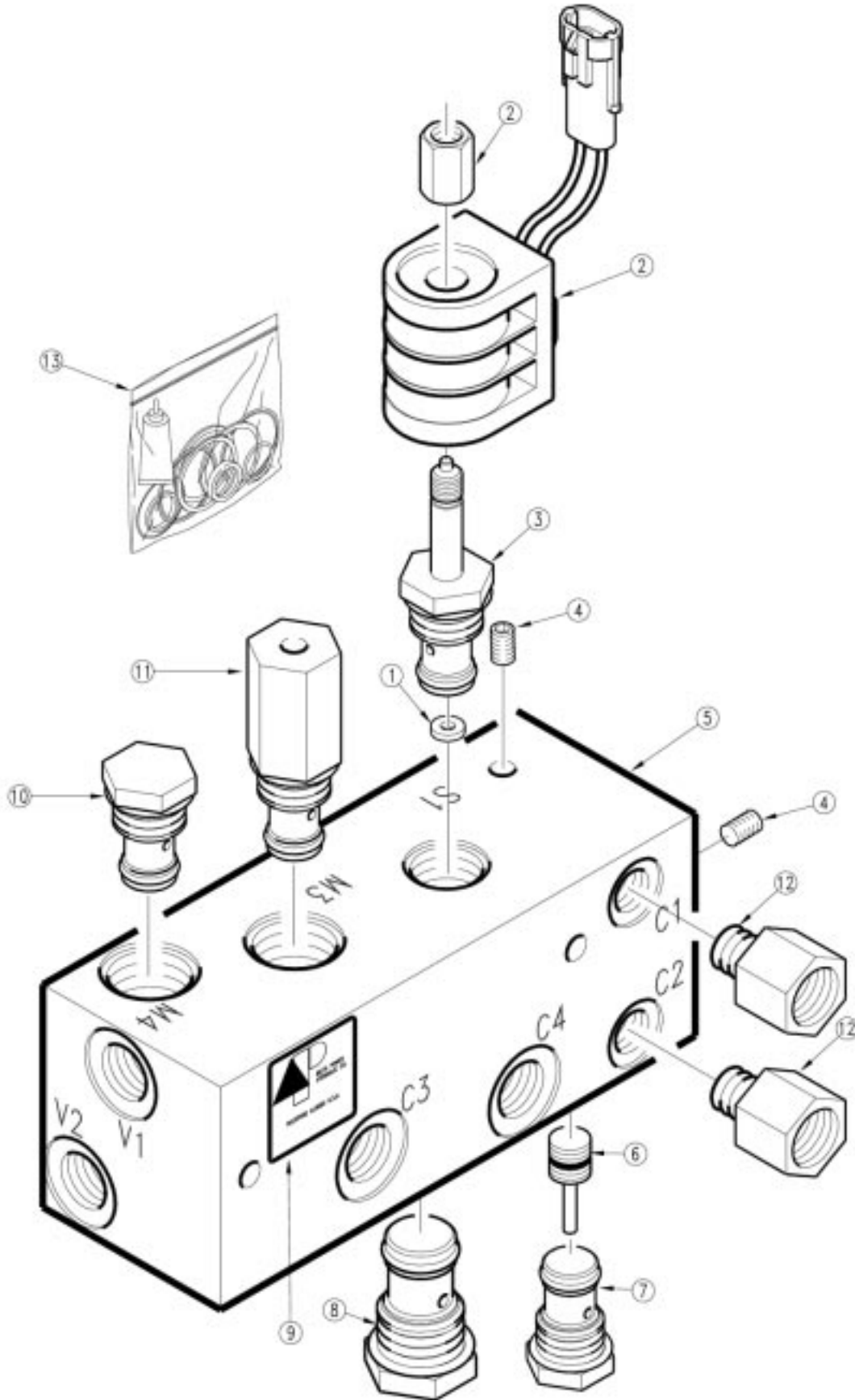

13479

Lift Circuit Manifold (810-262C)

Ref.	Part No.	Part Description	Comments
1.	34702171	DELTA ORIFICE DISK .031	
2.	39680008	DELTA COIL 12VDC W CONN	
3.	86020224	DELTA N.C. BI-DIR	
4.	61000000	DELTA 1/16 NPT PLUG	
5.	30102663	DELTA MANIFOLD	
6.	34952061	DELTA PISTON ASSEMBLY	
7.	86020028	DELTA CHECK VALVE	
8.	87410001	DELTA SUPER CHECK	
9.	62010018	DELTA MANIFOLD TAG	
10.	33702007	DELTA CAVITY PLUG	
11.	85002929	DELTA P.O. RELIEF VALVE	
12.	10000001	FTG #4SAE M-#6SAE F F/810-262C	
13.		SEAL KIT FOR CARTRIDGE VALVES	Refer to the illustrations below for proper seal kit identification.

NOTE: Each o-ring kit contains all of the o-rings for the series of valve on which it is used. Not all of the seals will be used on every valve.
 Each kit also contains a packet of sealant which is to be used on the threads of the valve when it is re-installed into the manifold.

Seal Kits For Cartridges in Lift Circuit Manifold 810-262C

Relief Valve

Use Seal Kit 810-228C (Ref. Item #11)

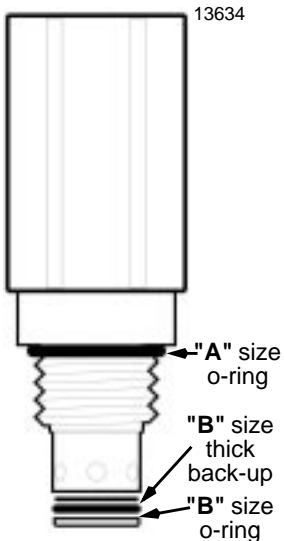

NC Bi-Dir

Use Seal Kit 810-271C (Ref. Item #3)

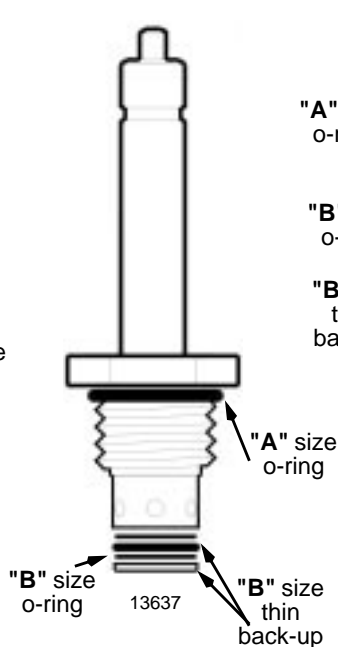

Super Check

Use Seal Kit 810-235C (Ref. Item #8)

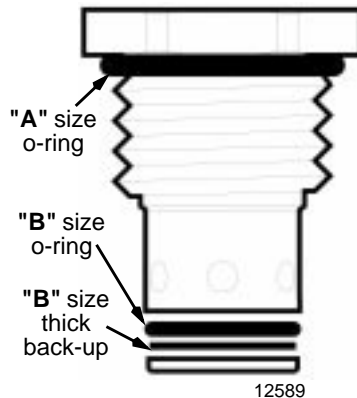

Check Valve

Use Seal Kit 810-272C (Ref. Item #7)

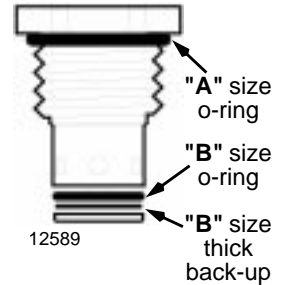

Piston Assy.

Use Seal Kit 810-271C (Ref. Item #6)

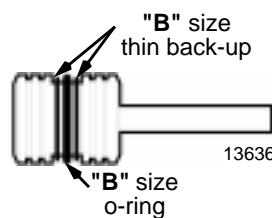

Cavity Plug

Use Seal Kit 810-228C (Ref. Item #10)

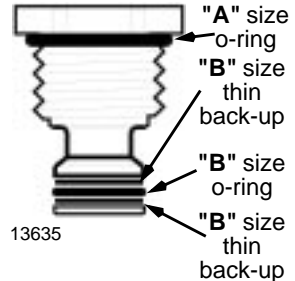

Legend: ● = 1st revision; ● = 2nd revision; ● = 3rd revision; ● = use up existing stock; ⊗ = not interchangeable; ⊗ ⊕ ● = for example: revision 2 is not interchangeable w/revision 1

Coulter Depth Control Valve (810-214C)

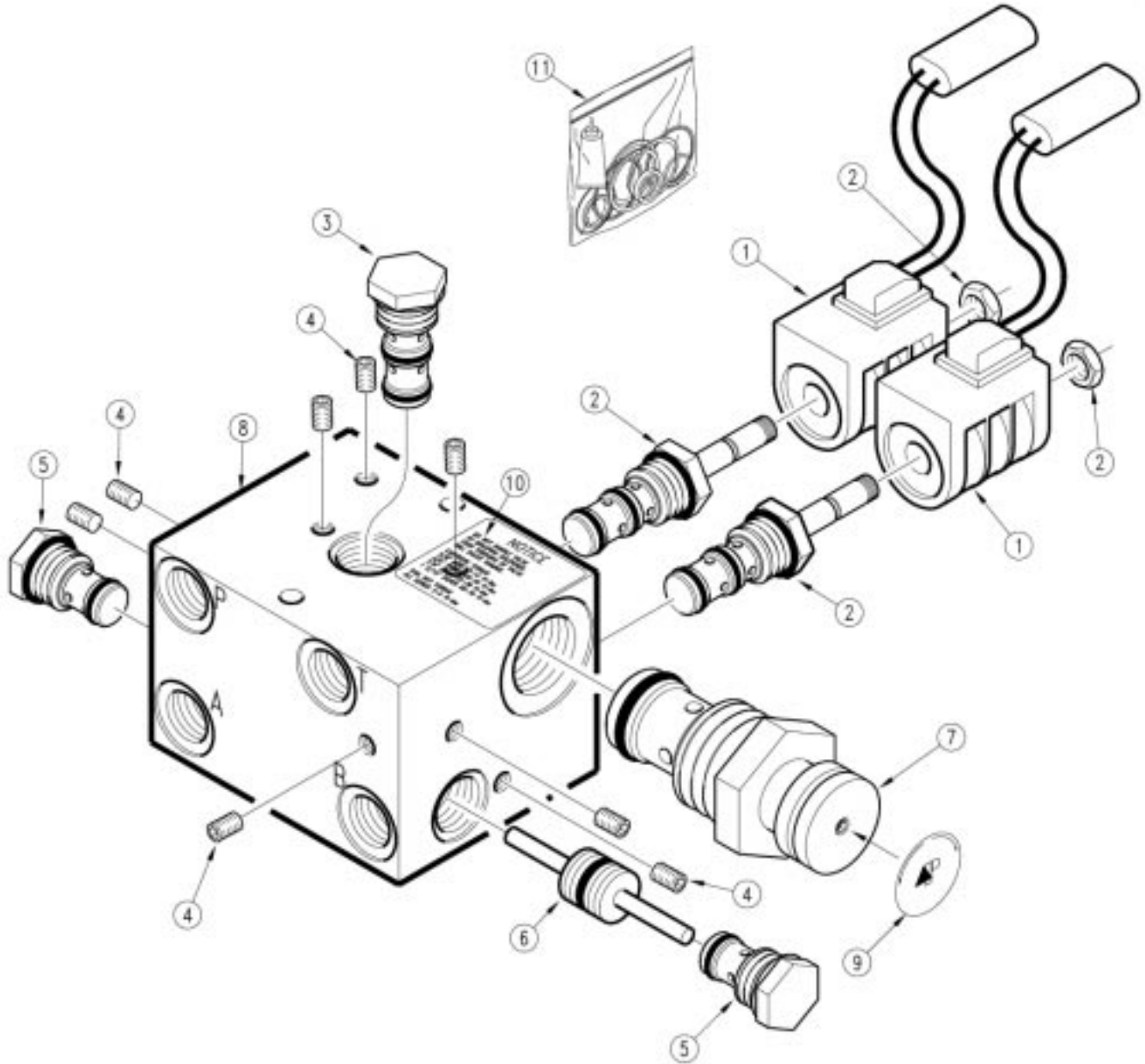

12292

Coulter Depth Control Valve (810-214C)

Ref.	Part No.	Part Description	Comments
1.	39680008	DELTA COIL 12VDC W CONN	
2.	85002279	DELTA 3W2P VALVE	
3.	810-265C	SHUTTLE VALVE HARDENED CASE	
4.	61000000	DELTA 1/16 NPT PLUG	
5.	85002006	DELTA CHECK VALVE	
6.	34952104	DELTA PISTON ASSY	
7.	87410043	DELTA PCR VALVE	
8.	30102610	DELTA COULTER COMMAND MANIFOLD	
9.	62010056	DELTA PCR STICKER	
10.	62010053	DELTA NOTICE TAG	
11.		SEAL KIT FOR CARTRIDGE VALVES	Refer to the illustrations below for proper seal kit identification.

NOTE: Each o-ring kit contains all of the o-rings for the series of valve on which it is used. Not all of the seals will be used on every valve.

Each kit also contains a packet of sealant which is to be used on the threads of the valve when it is re-installed into the manifold.

Seal Kits For Coulter Depth Control Valves
 Refer to 2-8 For Full Scale O-Ring/Back-up Ring Identification Chart

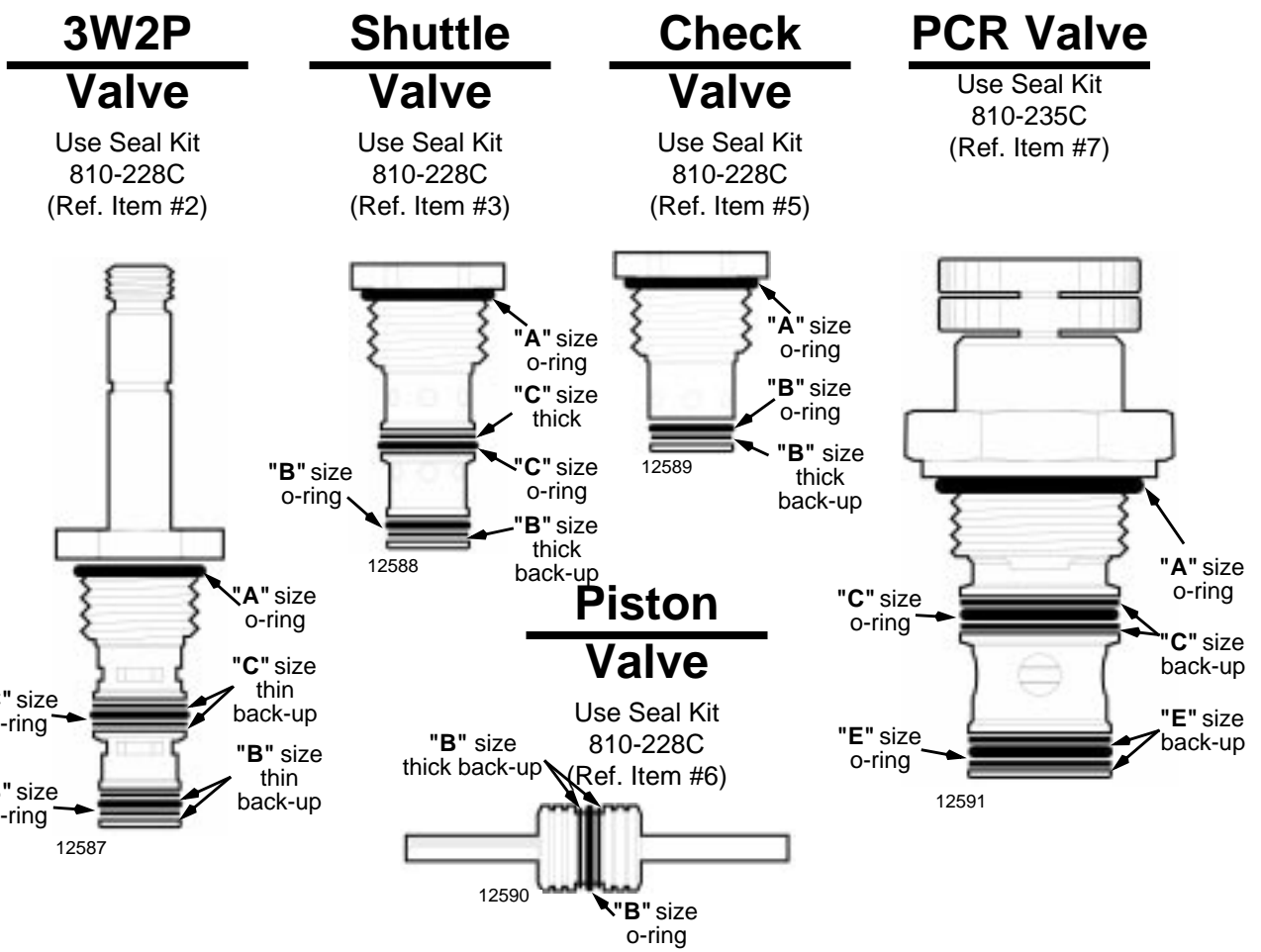

Legend: ● = 1st revision; ● = 2nd revision; ● = 3rd revision; ● = use up existing stock; ⊗ = not interchangeable; ⊗ ⊕ = for example: revision 2 is not interchangeable w/revision 1

Seal Kit for Depth Control Valves

**810-228C For
7/8"-14 Series Valves**

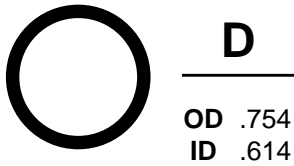

**810-235C For
1 5/16"-12 Series Valves**

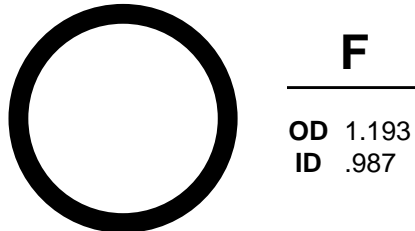
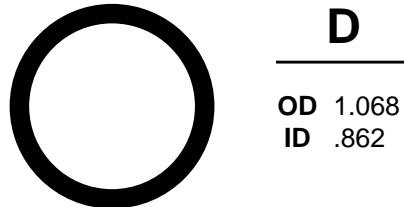
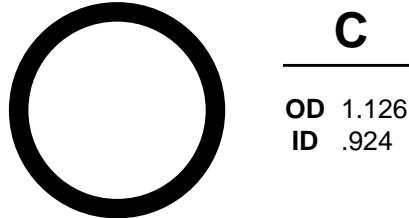
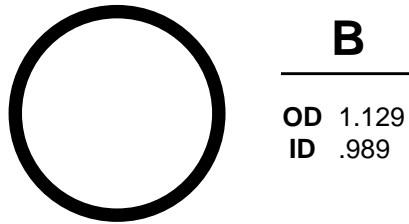
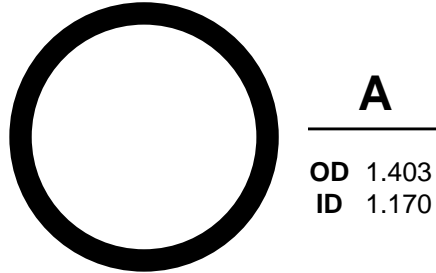

**810-271C For
3/4"-16 Series Valves**

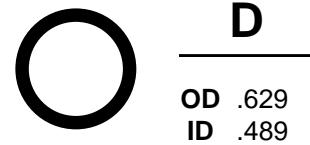
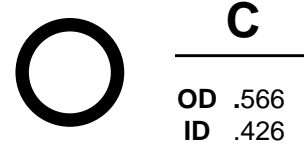
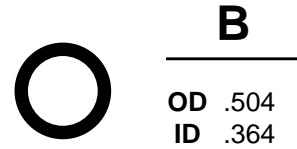

**810-272C For
5/8"-18 Check Valves**

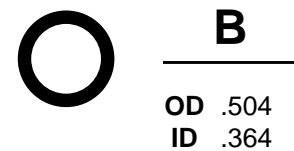

Scale: 1=1

Seal Kit for Depth Control Valves

Ref.	Part No.	Part Description	Comments
1.	810-228C	For 7/8"-12 Series Valves Includes: 2 Each Of The Thin Back-Up Rings, Sizes B, C, And D 1 Each of The Thick Back-Up Rings, Sizes C and D. 2 Thick "B" Size Back-Up Rings 1 Each Of O-Rings Sizes A, B, C, And D	
2.	810-235C	For 1 5/16"-12 Series Valves Includes: 1 Each of Sizes A, B, C, D, E, And F 2 Each of Back-Up Rings Sizes B, C, D, E, And F	
3.	810-271C	For 3/4"-16 Series Valves Includes :2 Each Of The Thin Back-Up Rings, Sizes B, C, And D 1 Each of The Thick Back-Up Rings, Sizes B. 1 Each Of O-Rings Sizes A, B, C, And D	
4.	810-272C	For 5/8"-18 Check Valves Includes: 1 Each of The Thick Back-Up Rings, Sizes B. 1 Each Of O-Rings Sizes A, And B.	

Legend: ● = 1st revision; ● = 2nd revision; ● = 3rd revision; ● = use up existing stock; ⊗ = not interchangeable; ⊗ ① ● = for example: revision 2 is not interchangeable w/revision 1

Decal Placement

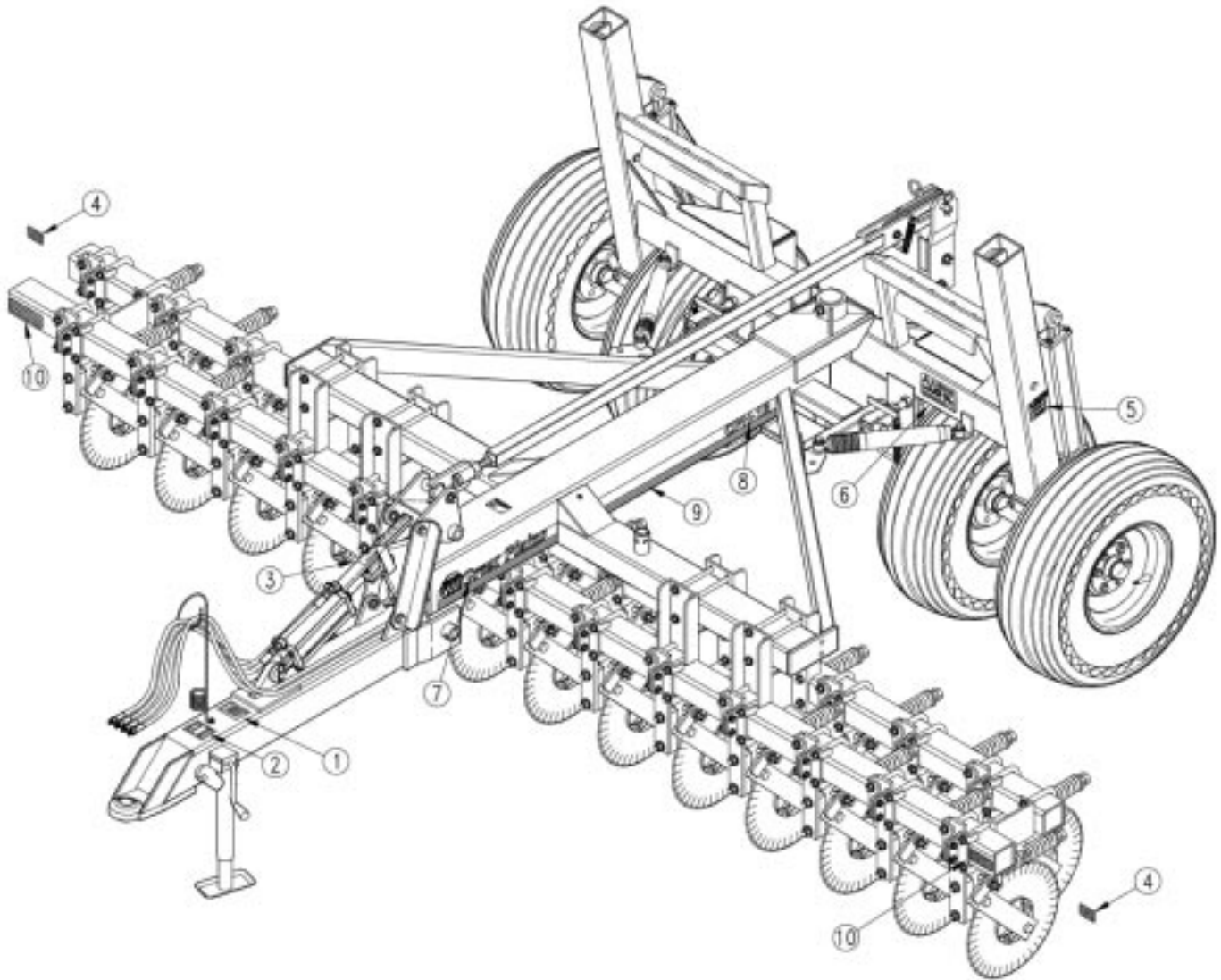

12076

Decal Placement

Ref.	Part No.	Part Description	Comments
1.	818-016C	DECAL CAUTION PIVOT PULL HITCH	
2.	818-019C	DECAL WARNING NEG TONGUE WT	
3.	818-181C	DECAL STROKE GAUGE	
4.	818-229C	DECAL AMBER REFLECTOR	
5.	818-398C	DECAL CAUTION TIRES NOT A STEP	
6.	818-188C	DECAL WARNING 20 MPH TRANS LRG	
7.	⊗ ① ② 838-161C	DECAL LOGO&GP F/STRIPE 4 X 24	2000+
	① 818-416C	DECAL GREAT PLAINS LOGO	1994↔1999
8.	⊗ ① ② 838-215C	DECAL CPH-12	2000+
	① 818-417C	DECAL CENTER PIVOT HITCH 1200	1994↔1999
	⊗ ① ② 838-216C	DECAL CPH-15	2000+
	① 818-418C	DECAL CENTER PIVOT HITCH 1500	1994↔1999
	⊗ ① ② 838-217C	DECAL CPH-20	2000+
	① 818-419C	DECAL CENTER PIVOT HITCH 2000	1994↔1999
9.	838-160C	DECAL 3 COLOR STRIPE 2.50 WIDE	2000+
10.	838-265C	DECAL REFLECTOR AMBER 1 1/2X9	2001+

Legend: ① = 1st revision; ② = 2nd revision; ③ = 3rd revision; ● = use up existing stock; ⊗ = not interchangeable; ⊗ ① ② = for example: revision 2 is not interchangeable w/revision 1

Coulter Depth Control Hydraulics

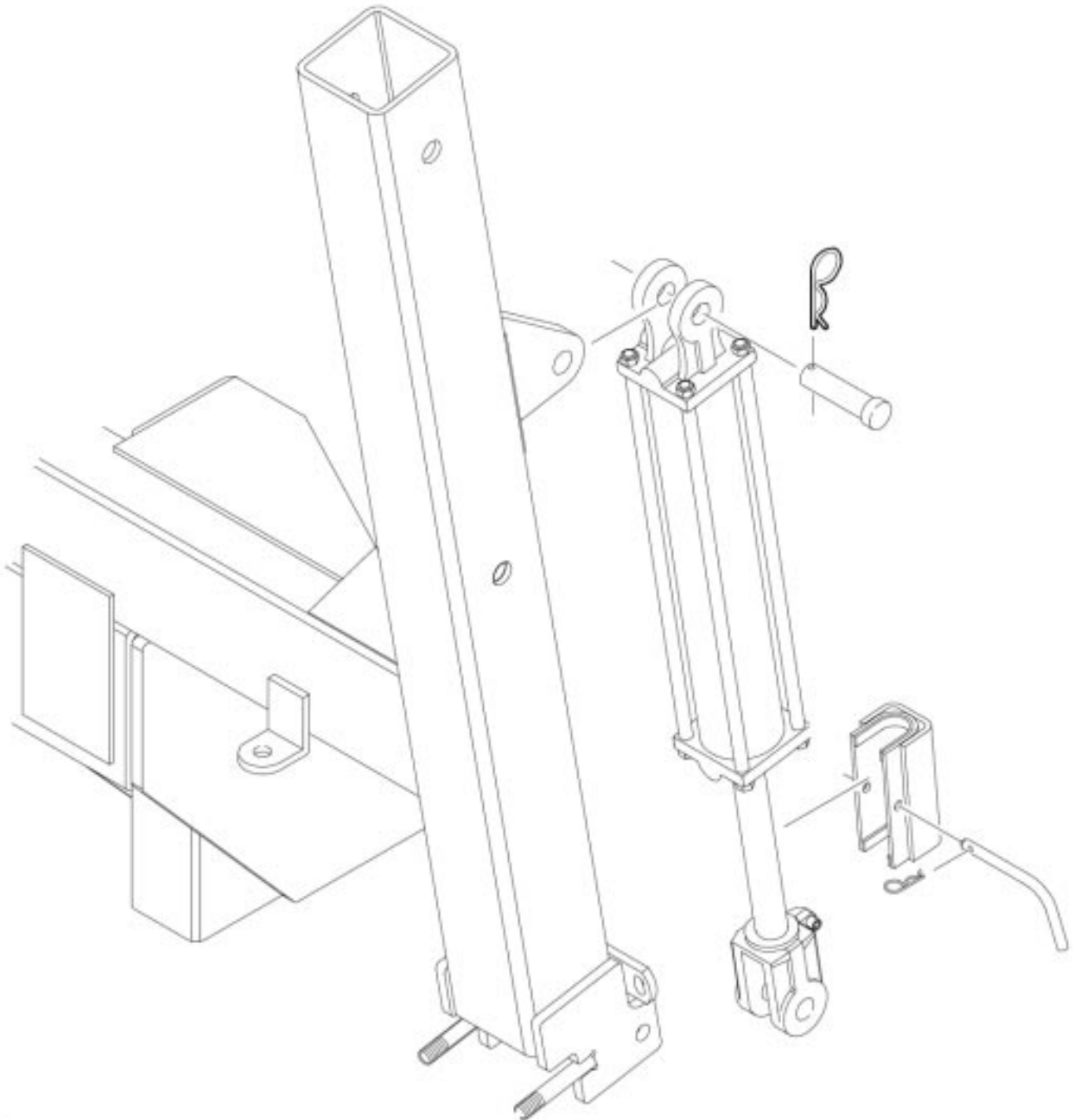

13182

Coulter Depth Control Hydraulics

Ref.	Part No.	Part Description	Comments
1.	148-266S	6 CYL DEPTH CHANNEL ASY	
2.	805-152C	BENT PIN 3/8 X 2 1/2 USE W/COT	

Legend: ① = 1st revision; ② = 2nd revision; ③ = 3rd revision; ● = use up existing stock; ⊗ = not interchangeable; ⊗ ① ② = for example: revision 2 is not interchangeable w/revision 1

Coulter Tool Bar Brace

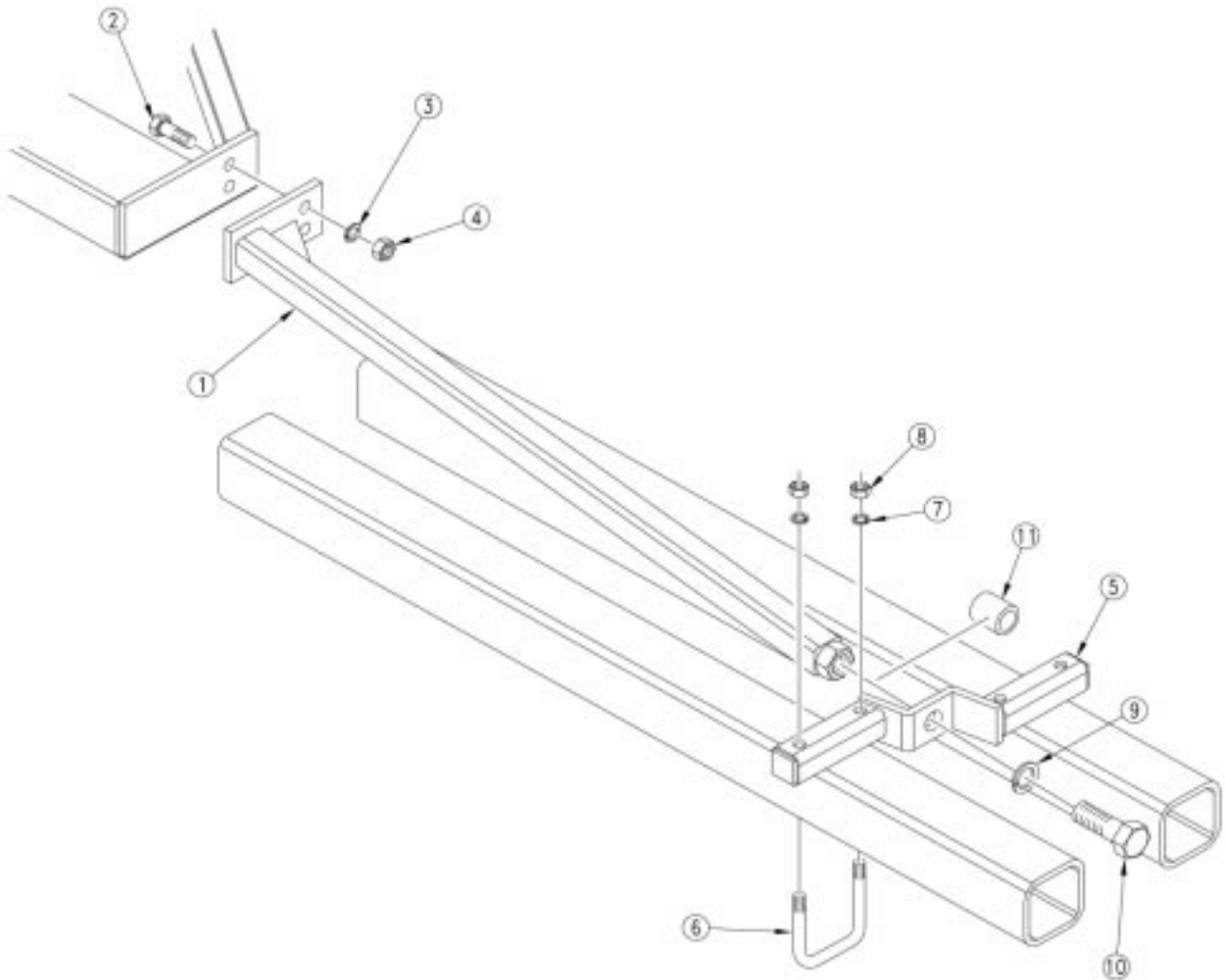

11979

Coulter Tool Bar Brace

Ref.	Part No.	Part Description	Comments
1.	149-166H	20'CPH TOOL BAR BRACE WLMT LH	
	149-167H	20'CPH TOOL BAR BRACE WLMT RH	
2.	802-064C	HHCS 3/4-10X2 GR5	
3.	804-023C	WASHER LOCK SPRING 3/4 PLT	
4.	803-027C	NUT HEX 3/4-10 PLT	
5.	149-165H	20'TOOL BAR SUPPORT WLMT	
6.	806-063C	U-BOLT 5/8-11 X 4 1/32 X 7	
7.	804-022C	WASHER LOCK SPRING 5/8 PLT	
8.	803-021C	NUT HEX 5/8-11 PLT	
9.	804-030C	WASHER LOCK 1 1/4 SPRING PLT	
10.	802-123C	HHCS 1 1/4-7X2 1/2 GR5	
11.	149-586D	CPH BRACE KIT SPACER	

Legend: ① = 1st revision; ② = 2nd revision; ③ = 3rd revision; ● = use up existing stock; ⊗ = not interchangeable; ⊗ ① ② = for example: revision 2 is not interchangeable w/revision 1

Weight Frame Bracket (149-168A)

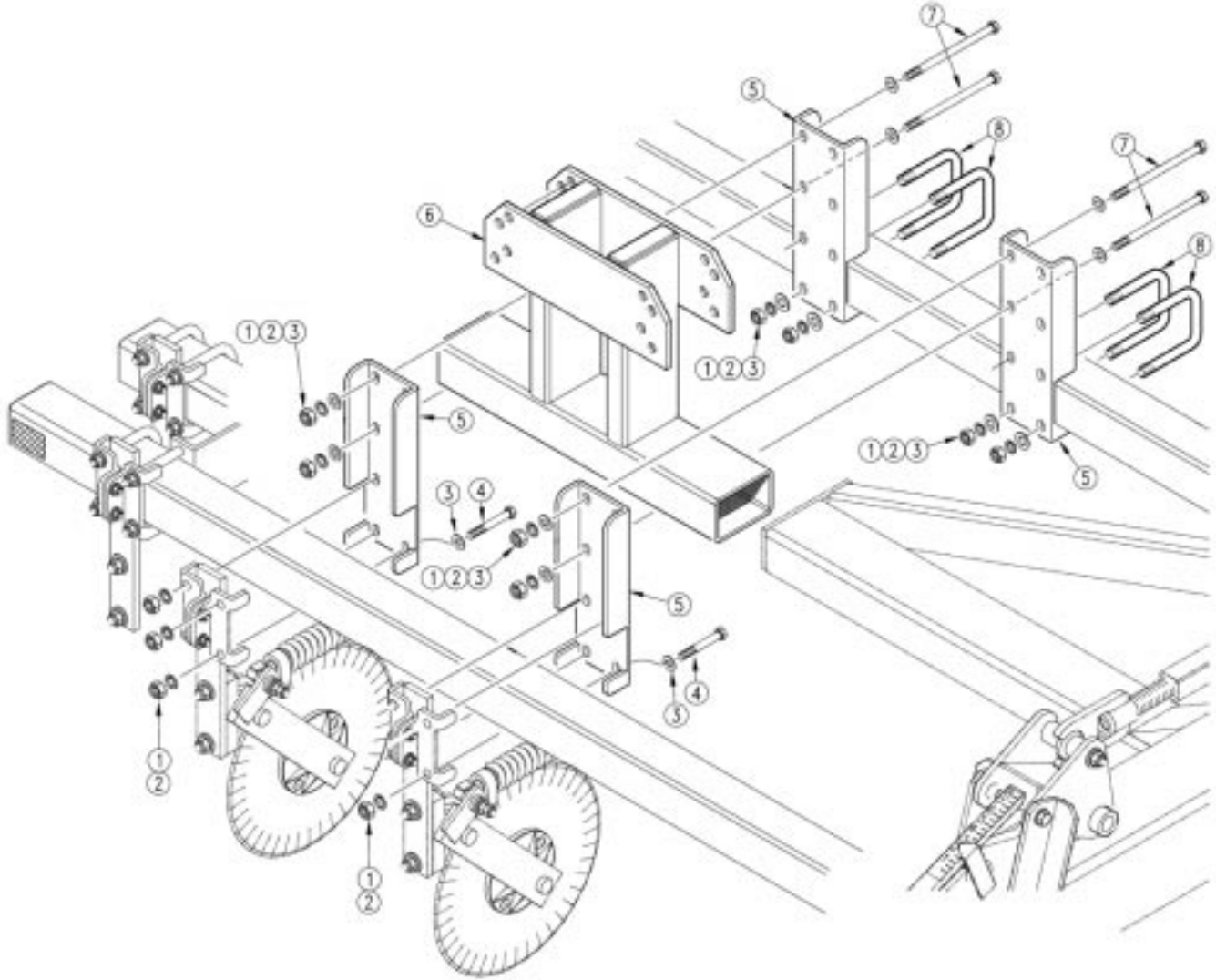

12138

Weight Frame Bracket (149-168A)

Ref.	Part No.	Part Description	Comments
1.	803-021C	NUT HEX 5/8-11 PLT	
2.	804-022C	WASHER LOCK SPRING 5/8 PLT	
3.	804-019C	WASHER FLAT 5/8 USS PLT	
4.	802-335C	HHCS 5/8-11X6 1/2 GR5	
5.	149-072D	COULTER BAR CLAMP	
6.	149-058H	TOOL BAR WEIGHT BRACKET FRAME	
7.	802-208C	HHCS 5/8-11X8 GR5	
8.	806-105C	U-BOLT 5/8-11 X 4 1/32 X 6	

Legend: ① = 1st revision; ② = 2nd revision; ③ = 3rd revision; ● = use up existing stock; ⊗ = not interchangeable; ⊗ ① ② = for example: revision 2 is not interchangeable w/revision 1

John Deere Weight Bracket (149-032A)

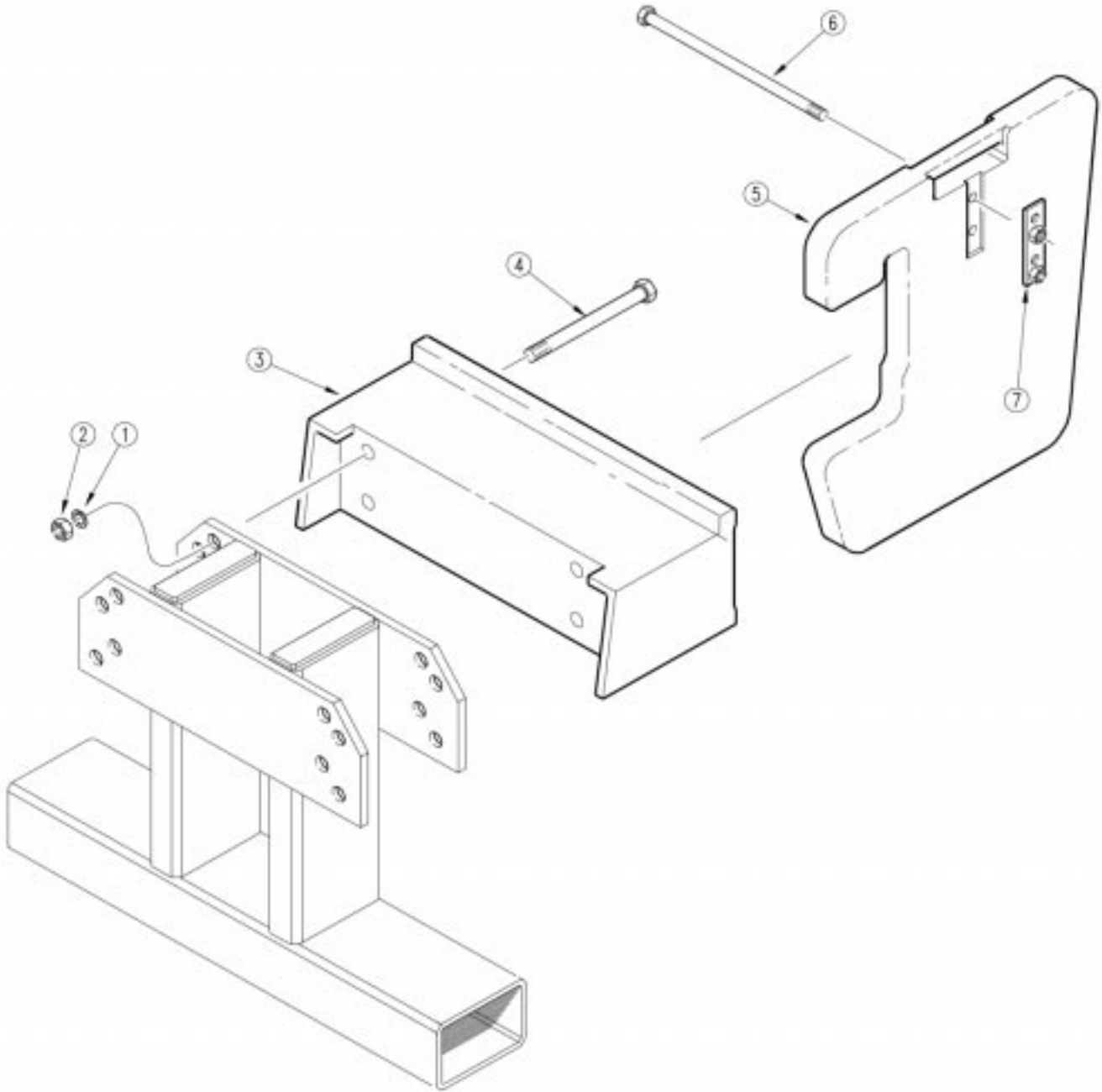

12140

John Deere Weight Bracket (149-032A)

Ref.	Part No.	Part Description	Comments
1.	804-023C	WASHER LOCK SPRING 3/4 PLT	
2.	803-027C	NUT HEX 3/4-10 PLT	
3.	812-015C	CASTING J.D. WEIGHT BRACKET	
4.	802-095C	HHCS 3/4-10X7 GR5	
5.	812-017C	CASTING JD SUITCASE WEIGHT	
6.	802-112C	HHCS 5/8-11X14 GR5	
7.	149-059H	NUT STRAP WELDMENT	

Legend: ① = 1st revision; ② = 2nd revision; ③ = 3rd revision; ● = use up existing stock; ⊗ = not interchangeable; ⊗ ① ② = for example: revision 2 is not interchangeable w/revision 1

Case I.H. Weight Bracket (149-034A)

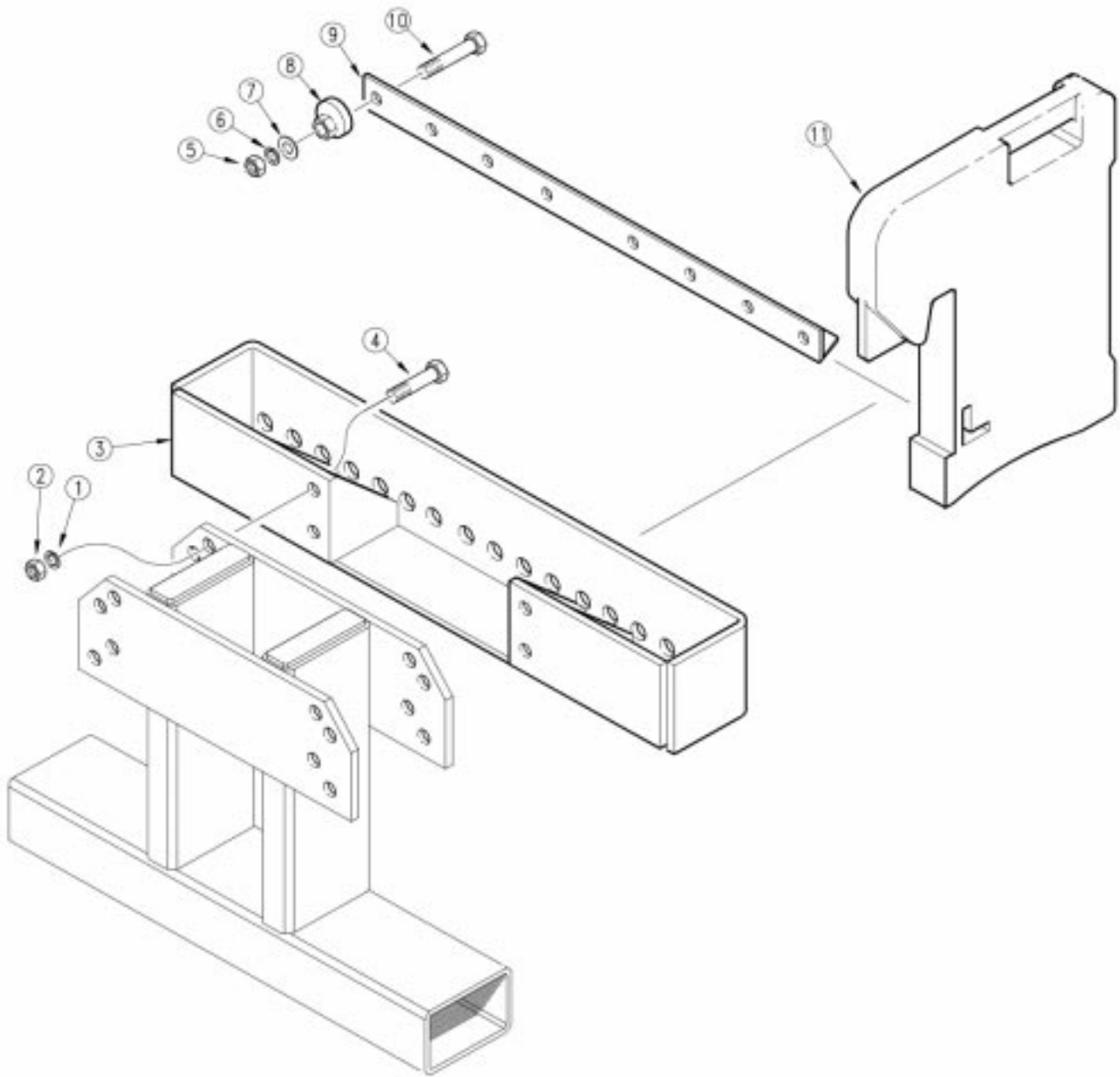

12141

Case I.H. Weight Bracket (149-034A)

Ref.	Part No.	Part Description	Comments
1.	804-023C	WASHER LOCK SPRING 3/4 PLT	
2.	803-027C	NUT HEX 3/4-10 PLT	
3.	149-057H	I.H. STEEL WEIGHT BRACKET	
4.	802-065C	HHCS 3/4-10X2 1/4 GR5	
5.	803-021C	NUT HEX 5/8-11 PLT	
6.	804-022C	WASHER LOCK SPRING 5/8 PLT	
7.	804-021C	WASHER FLAT 5/8 SAE PLT	
8.	812-016C	CASTING CAM	
9.	149-046D	ANGLE LOCK BAR	
10.	802-059C	HHCS 5/8-11X3 GR5	
11.	812-018C	CASTING IH SUITCASE WEIGHT	
	812-019C	CASTING CASE SUITCASE WEIGHT	

Legend: ① = 1st revision; ② = 2nd revision; ③ = 3rd revision; ● = use up existing stock; ⊗ = not interchangeable; ⊗ ① ② = for example: revision 2 is not interchangeable w/revision 1