

Parts Manual

1510P & 1520P
Precision Seeding System

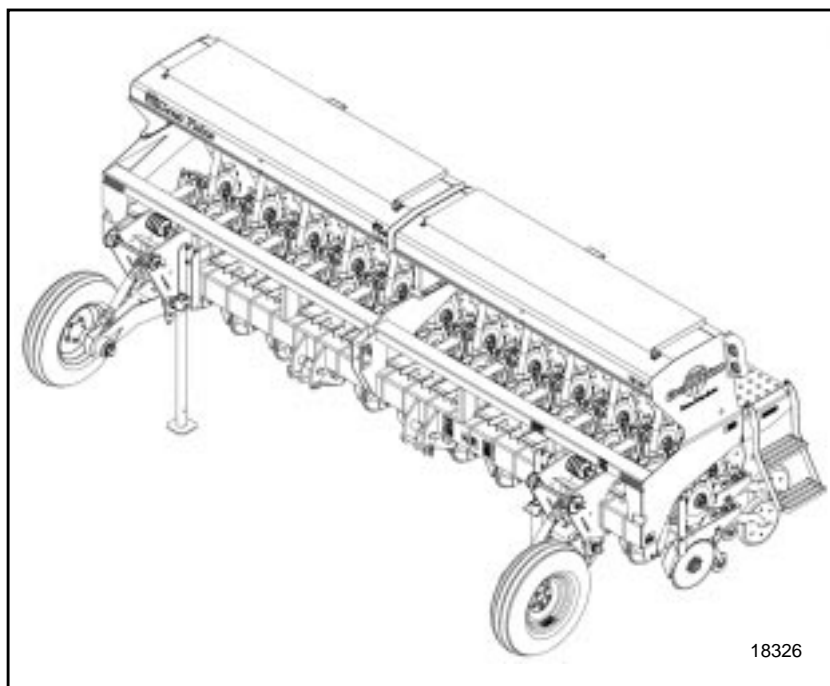

Read the operator's manual entirely. When you see this symbol, the subsequent instructions and warnings are serious - follow without exception. Your life and the lives of others depend on it!



Cover illustration may show optional equipment not supplied with standard unit.



Table of Contents

Section	1-1	1" x 10" Double "V" Press Wheel (10/1/2000+)	6-11
Section 1 Introduction	1-1	1" x 10" Double "V" Press Wheel (9/30/2000-)	6-13
General Information	1-1	1 1/4" x 13 1/2" Double Press Wheel	6-15
Using This Manual	1-1	1 1/4" x 13" Double Press Wheel	6-17
Manual Replacement Information	1-1	2" x 12 1/2" Double Press Wheel	6-19
Manual Revisions	1-1	2" x 12 1/2" Double Press Wheel	6-21
Touch-up Paint	1-1	Section 7 Decals	7-1
Hardware Legend	1-2	Decal Placement	7-1
Replacement Hardware	1-2	Section 8 Markers (Option)	8-1
Serial Numbers	1-2	Flat Fold Marker	8-1
Part Number Service Coding	1-2	Marker Disk And Hub (113-563S)	8-3
Part Number Index	1-3	Flat Fold Dual Marker Hydraulics	8-5
Section 2 Box Assembly	2-1	Flat Fold Marker Sequence Valve Hydraulics	8-7
Box To Frame	2-1	Hydraulic Cylinder 2 x 20 x 1.12 (810-205C)	8-9
Box Components	2-3	Sequence Valve (810-197C)	8-11
Lid To Box	2-5	Section 9 Harrow (Option)	9-1
Seed Level Indicator	2-7	Harrow	9-1
Walkboard And Ladder (SN 10337C-)	2-9	Section 10 Monitor (Option)	10-1
Walkboard And Ladder (SN 10338C-10513C)	2-11	Monitor (S/N 10681C-)	10-1
Walkboard And Ladder (S/N 10542C+)	2-13	Monitor 833-279C 7.5" Spacing (S/N 10682C+)	10-3
Section 3 Metering System	3-1	Monitor 833-280C 10" Spacing (S/N 10682C+)	10-5
Singulating Meter	3-1	Monitor 833-281C 15" Spacing (S/N 10682C+)	10-7
Seed Tray With Telescoping Tubes	3-3	Section 11 Baffle (Option)	11-1
Section 4 Drive	4-1	Twin Row Baffle	11-1
Single Gauge Wheel (S/N 10696C -)	4-1	Section 12 Microband (Option)	12-1
Single Gauge Wheel (S/N 10697C+)	4-3	Microband Twin Row Components (S/N 10513C-)	12-1
Dual Gauge Wheel (S/N 10697C+)	4-5	Microband Every Row Components (S/N 10513C-)	12-3
Gauge Wheel LH	4-7	Microband Components (S/N 10542C+)	12-5
Gauge Wheel RH	4-9	Microband Hopper Components	12-7
Gauge Wheel Transmission (S/N 10513C -)	4-11	Microband Drive (S/N 10513C-)	12-9
Gauge Wheel Transmission (S/N 10542C +)	4-13	Microband Drive (S/N 10542+)	12-11
Section 5 Openers	5-1	Section 13 Section 13 Small Seeds (Option)	13-1
10 Series Opener Arms & Mounts (S/N 10513C -)	5-1	Small Seeds Box Mounting	13-1
10 Series Opener Arms & Mounts (S/N 10542C +)	5-3	Small Seeds Box Components	13-3
10 Series Opener Body (S/N 10679C-)	5-5	Small Seeds Drive	13-5
10 Series Opener Body (S/N 10680C+)	5-7	Small Seeds 10 Series Seed Tube	13-7
20 Series Opener Arms & Mounts (S/N 10513C -)	5-9	Small Seeds 20 Series Seed Tube	13-9
20 Series Opener Arms & Mounts (S/N 10542C+)	5-11	Small Seeds Decal Placement	13-11
20 Series Opener Body	5-13	Section 14 Veris Drive (Option)	14-1
Keeton Seed Firmer (Option)	5-15	Veris Drive To Frame	14-1
Air Design Scraper (Option)	5-17	Veris Drive Components	14-3
Side Wheel Scraper (Option)	5-19	Veris Drive Controller	14-5
10 & 20 Series Seed-Lok (Option)	5-21		
Section 6 Press Wheels	6-1		
2" x 13" Single Press Wheel	6-1		
3" x 13" Single Press Wheel	6-3		
1" x 12" Double "V" Press Wheel	6-5		
1" x 12" Double "V" Press Wheel Short	6-7		
1" x 12" Double "V" Press Wheel Long	6-9		

© Copyright 2001 All rights Reserved

Great Plains Manufacturing, Inc. provides this publication "as is" without warranty of any kind, either expressed or implied. While every precaution has been taken in the preparation of this manual, Great Plains Manufacturing, Inc. assumes no responsibility for errors or omissions. Neither is any liability assumed for damages resulting from the use of the information contained herein. Great Plains Manufacturing, Inc. reserves the right to revise and improve its products as it sees fit. This publication describes the state of this product at the time of its publication, and may not reflect the product in the future.

Great Plains Manufacturing, Incorporated Trademarks
The following are trademarks of Great Plains Mfg., Inc.: Application Systems, Ausherman, Land Pride, Great Plains

All other brands and product names are trademarks or registered trademarks of their respective holders.

Printed in the United States of America.



Alphabetical Page Index

Numerics

1 1/4" x 13 1/2" Double Press Wheel	.6-15
1 1/4" x 13" Double Press Wheel	.6-17
1" x 10" Double "V" Press Wheel	.6-13
1" x 12" Double "V" Press Wheel	.6-5
1" x 12" Double "V" Press Wheel Long	.6-9
1" x 12" Double "V" Press Wheel Short	.6-7
10 & 20 Series Seed-Lok	.5-21
10 Series Opener Arms & Mounts	.5-1
10 Series Opener Body	.5-5
10 Series Opener Body (S/N 10680C+)	.5-7
2" x 12 1/2" Double Press Wheel	.6-19, 6-21
2" x 13" Single Press Wheel	.6-1
20 Series Opener Arms & Mounts	.5-9
20 Series Opener Body	.5-13
3" x 13" Single Press Wheel	.6-3

A

Air Design Scraper (Option)	.5-17
-----------------------------	-------

B

Box Components And Sliding Seed Tubes	.2-3
Box To Frame	.2-1

D

Decal Placement	.7-1
Dual Gauge Wheel (S/N 10697C+)	.4-5

F

Flat Fold Dual Marker Hydraulics	.8-5
Flat Fold Marker	.8-1
Flat Fold Marker Sequence Valve Hydraulics	.8-7

G

Gauge Wheel Drive	.4-7
Gauge Wheel Transmission	.4-11
Gauge Wheel Transmission (S/N 10513C +)	.4-13

H

Harrow	.9-1
Hydraulic Cylinder 2 x 20 x 1.12 (810-205C)	.8-9

K

Keeton Seed Firmer (Option)	.5-15
-----------------------------	-------

L

Lid To Box	.2-5
------------	------

M

Marker Disk And Hub (113-563S)	.8-3
Microband Components (S/N 10542C+)	.12-5
Microband Drive (S/N 10513C-)	.12-9
Microband Drive (S/N 10542+)	.12-11
Microband Every Row Components (S/N 10513C-)	.12-3
Microband Hopper Components	.12-7
Microband Twin Row Components (S/N 10513C-)	.12-1
Monitor (S/N 10681C-)	.10-1
Monitor 833-279C 7.5" Spacing (S/N 10682C+)	.10-3
Monitor 833-280C 10" Spacing (S/N 10682C+)	.10-5
Monitor 833-281C 15" Spacing (S/N 10682C+)	.10-7

S

Seed Level Indicator	.2-7
Seed Tray With Telescoping Tubes	.3-3
Sequence Valve (810-197C)	.8-11
Side Wheel Scraper (Option)	.5-19
Single Gauge Wheel (S/N 10696C-)	.4-1
Single Gauge Wheel (S/N 10697C+)	.4-3
Singulating Meter	.3-1
Small Seede Box Components	.13-3
Small Seeds 10 Series Seed Tube	.13-7
Small Seeds 20 Series Seed Tube	.13-9
Small Seeds Box Mounting	.13-1
Small Seeds Decal Placement	.13-11
Small Seeds Drive	.13-5

T

Twin Row Baffle (Option)	.11-1
--------------------------	-------

V

Veris Drive Components	.14-3
Veris Drive Controller	.14-5
Veris Drive To Frame	.14-1

W

Walkboard And Ladder	.2-9
Walkboard And Ladder (S/N 10542C+)	.2-13
Walkboard and Ladder (SN 10338C+)	.2-11



General Information

Using This Manual

This manual is divided into sections. The first section contains General Information, a Table of Contents, an Alphabetical Page Index, and a Part Number Index. The remaining sections divide the machine into segments (i.e. Frames, Drives, Hydraulics, etc.) which illustrate and list all parts.

The Great Plains parts in this manual are specially designed for this machine and should be replaced with Great Plains parts only.

The information in this manual is current at printing. Some parts may change to assure top performance.

Right-hand and left-hand as used in this manual are determined by facing the direction the machine will travel while in use.

Below is an example of two facing pages from a parts manual. Familiarize yourself with the contents of these pages.

Manual Replacement Information

Replacement manuals are available. Refer to your dealer or the Great Plains Publications Catalog for additional information.

Manual Revisions

When this manual is revised, the modification date is printed on the front cover and on the revised page(s).

Touch-up Paint

Repaint parts where paint is worn or scratched to prevent rust. Aerosol touch-up paint is available. To order use Great Plains parts numbers below:

- GP Green 821-001C
- GP Black 821-002C
- GP Beige 821-003C
- GP Buckskin 821-004C

The diagram shows two facing pages from a parts manual. The left page is an illustration page for 'Tongue & Pull Bar (S/N 00000-)'. It features a technical drawing of the component with numbered callouts (1-24) and a table of parts. The right page is a parts list page for 'Frames | 2-2', containing a list of 24 parts with their respective part numbers and descriptions. Labels with arrows point to various elements: Page Number (2-1), Manual Name (CF500 and CF600), Serial Number Break (S/N 00000-), Illustration Page, Parts Page, Section Name (Frames | 2-2), Section Number (2), Illustration Heading (Tongue & Pull Bar (S/N 00000-)), Illustration (technical drawing), Illustration Number (10207), Manual Number (175-083P), New or Modification Date (7/1/99), and Parts List (table of parts).

Hardware Legend

AR	As Required
BLADE	Blade Bolt
C	Cap Screw
CP	Cotter Pin
CPHSSS	Cup Point Hex Socket Set Screw
CPSHSS	Cup Point Square Head Set Screw
CPSQHSS	Cup Point Square Head Set Screw
CRFCHMS	Cross Recess Flat Countersunk Head Mach. Screw
CRPHMS	Cross Recess Pan Head Machine Screw
CRPHTFS	Cross Recess Pan Head Thread Forming
CRRHMS	Cross Recess Round Head Machine Screw
CRTHMS	Cross Recess Truss Head Machine Screw
CSNB	Countersunk Square Neck Bolt
FHMS	Flat Head Machine Screw
FTC	Full Thread Cap Screw
H	Hex Nut
HCLN	Hex Center Lock Nut
HFLCS	Hex Flange Lock Cap Screw
HFS	Hex Flange Screw
HFSLN	Hex Flange Serrated Lock Nut
HFSS	Hex Flange Serrated Screw
HHCS	Hex Head Cap Screw or Metric Bolt
HSBHCS	Hex Socket Button Head Cap Screw
HSFCHCS	Hex Socket Flat Countersunk Head Cap Screw
HSHCS	Hex Socket Head Cap Screw
HSSS	Hex Socket Head Screw
HTLN	Hex Top Lock Nut
HWHCS	Hex Washer Head Cap Screw

HWHMS	Hex Washer Head Machine Screw
HXBHCS	Hex Socket Button Head Cap Screw
J	Hex Jam Nut
JIC	37 Degree Tapered Thread
L	Helical Spring Lock Washer
LUG	Lug Bolt
NFC	National Fine Cap Screw
NPSM	National Pipe Straight Mechanical
NPTF	National Pipe Taper Fuel
P	Wide Plain Washer
PHMS	Pan Head Machine Screw
PLOW	Plow Bolt
RHMS	Round Head Machine Screw
RHSNB	Round Head Square Neck Bolt
SCREW LEVELING	Leveling Screw
SCREW THUMB	Thumb Screw
SCREW WELD	Weld Screw
SFCHMS	Slotted Flat Countersunk Head Machine Screw
SFHMS	Slotted Fillister Head Machine Screw
SP	Special
SP SCREW	Special Screw
SQHSS	Square Head Set Screw
SRHMS	Slotted Round Head Machine Screw
SSS	Socket Set Screw
STCS	Self Tapping Cap Screw
STHMS	Slotted Truss Head Machine Screw
WHEEL	Wheel Studs and Hub Long Bolts
WING	Wing Bolt

Replacement Hardware

The **Hardware Legend** above lists hardware abbreviations used in the parts lists. All bolts and nuts are grade 5 unless otherwise noted. The use of improper grades of hardware can result in personal injury, damage to equipment, or loss of property.

Serial Numbers

Always use the serial and model number when ordering parts. Refer to the operator's manual for serial number plate location.

- (S/N 20001+ or S/N 20001 and above) Includes serial numbers 20001 and above (to the latest number)
- (S/N 10001↔20000) Includes serial numbers between 10000 and 20001
- (S/N 10000- or S/N 10000 and below) Includes serial numbers 10000 and below (to the earliest number)

Part Number Service Coding

Within the parts lists some part numbers are coded for revisions and interchangeability.

Bold face type indicates parts that have been revised. These parts are considered interchangeable unless otherwise noted.

Service Code Legend:

- ① First revision, e.g.; ② is 2nd revision, ③ is 3rd revision, etc.
(Greater numbers are the newest.)
- Use existing stock of this part before ordering the revision.
- ⊗ Not interchangeable
- ⊗①② Revision 2 is not interchangeable w/1

The sample below shows how these codes are used.

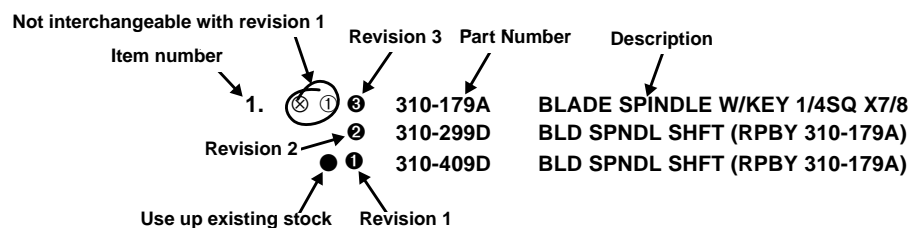

Part Number Index

<u>Part Number</u>	<u>Page</u>	<u>Part Number</u>	<u>Page</u>	<u>Part Number</u>	<u>Page</u>	<u>Part Number</u>	<u>Page</u>
1-100-02-00	8-4	113-503H	8-2	118-714L	2-2	120-269S	4-8
001029	12-8	113-562H	8-4	118-716L	2-2	120-276H	4-12
1042	8-12	113-563S	8-2	118-726H	3-4	120-276H	4-14
1087-250	8-12	113-666D	8-2	118-727H	3-4	120-276H	4-8
1087-437	8-12	113-667D	8-2	118-728H	3-4	120-278D	4-8
1088-011	8-12	113-689H	8-2	118-809H	3-4	120-284D	4-10
1088-905	8-12	113-690H	8-2	119-032D	2-10	120-285D	4-12
1088-906	8-12	116-062H	9-2	119-032D	2-12	120-285D	4-14
1088-908	8-12	116-065H	9-2	119-032D	2-14	120-286D	4-10
1089-011	8-12	116-114D	9-2	119-153D	2-6	120-286D	4-8
1092-6-6	8-12	116-116D	9-2	119-154D	2-6	120-287D	4-10
1099	8-12	116-191D	9-2	119-155D	2-10	120-287D	4-8
1132-05	8-12	116-202H	9-2	119-190D	13-4	120-289D	4-12
1132-08	8-12	116-218H	12-2	119-190D	2-4	120-290D	4-12
1179	8-12	116-218H	12-4	119-211D	2-10	120-290D	4-14
1180	8-12	116-219H	12-10	119-211D	2-12	120-291D	4-12
1182	8-12	116-220H	12-2	119-211D	2-14	120-291D	4-14
1211	8-12	116-220H	12-4	119-225D	2-10	120-291S	4-8
1217	8-12	116-220H	12-6	119-230H	2-6	120-293D	14-2
1218	8-12	116-220H	13-8	119-254D	2-12	120-293D	4-12
2153	8-12	116-221H	12-2	119-254D	2-14	120-293D	4-14
003010	12-8	116-221H	12-4	119-260D	2-12	120-294H	14-2
003018	12-8	116-221H	12-6	119-260D	2-14	120-302H	4-4
003029	12-8	116-221H	13-10	119-265H	2-10	120-302H	4-6
3089	8-12	116-226D	9-2	119-266H	2-10	120-305D	12-10
004001	12-8	116-232D	12-2	119-277H	2-12	120-305D	12-12
006094	12-8	116-232D	12-4	119-277H	2-14	120-305D	12-12
012114	12-8	116-236D	12-10	119-278D	2-14	120-305D	4-12
018028	12-8	116-239D	12-10	119-279H	2-12	120-305D	4-14
038004	12-8	116-240D	12-10	119-280H	2-12	120-306D	12-10
075020	12-8	116-240D	13-6	119-281H	2-2	120-306D	12-12
094008	12-8	116-241D	12-10	119-282H	2-2	120-306D	4-12
095003	12-8	116-243H	12-6	119-292H	2-14	120-307D	4-14
098016	12-8	116-244H	12-6	119-293H	2-14	120-309D	14-6
137084	12-8	116-245D	4-14	119-294H	2-14	120-309D	4-8
160011	12-8	116-245H	12-6	120-001E	4-10	120-310D	4-8
200083	12-8	116-247D	12-2	120-001E	4-8	120-311D	4-8
200084	12-8	116-247D	12-4	120-188D	4-10	120-312D	4-2
301041	12-8	116-247D	12-6	120-188D	4-8	120-313D	4-14
302009	12-8	116-248D	12-2	120-197D	4-2	120-314A	4-2
302010	12-8	116-248D	12-6	120-197D	4-4	120-315D	4-10
464211340	10-4	116-248H	12-12	120-197D	4-6	120-315D	4-14
464211340	10-6	116-249D	12-4	120-198D	4-2	120-315D	4-8
464211340	10-8	116-249D	12-6	120-198D	4-4	120-315D	4-10
107-111D	5-14	116-250D	12-4	120-208H	4-2	120-316D	4-8
107-111D	5-6	116-250D	12-6	120-211H	14-2	120-319D	14-2
107-111D	5-8	116-262H	12-6	120-212H	4-2	120-320D	14-2
107-133S	5-14	116-272D	12-6	120-212H	4-4	120-326D	4-4
107-133S	5-6	116-274D	12-12	120-212H	4-6	120-326D	4-6
107-138S	5-14	116-277D	12-12	120-213H	4-10	120-327D	4-4
107-138S	5-8	116-279D	12-12	120-213H	4-8	120-328D	4-6
109-058K	4-2	116-281D	12-6	120-214H	4-10	122-120D	5-22
109-058K	4-4	116-282D	12-6	120-214H	4-8	122-164D	5-22
109-058K	4-6	116-290D	12-6	120-229D	4-10	122-165D	5-22
113-180H	8-2	117-057H	2-2	120-229D	4-8	122-166D	5-22
113-188H	8-2	117-059H	2-2	120-230D	4-2	122-167D	5-22
113-191H	8-2	117-323D	2-2	120-237S	4-2	122-168D	5-18
113-248D	8-2	118-402D	2-4	120-242D	4-2	122-169D	5-6
113-312D	8-2	118-403D	2-4	120-242D	4-4	122-169D	5-8
113-313D	8-2	118-414H	2-4	120-242D	4-6	122-201S	5-22
113-324D	8-2	118-453H	2-4	120-245S	4-10	122-202S	6-16
113-325D	8-2	118-474H	2-8	120-245S	4-8	122-202S	6-2
113-351D	8-2	118-486D	2-4	120-253D	4-4	122-202S	6-20
113-369H	8-4	118-487D	2-4	120-253D	4-6	122-202S	6-4
113-467H	8-2	118-498D	2-8	120-264D	4-10	122-202S	6-6
113-468H	8-2	118-539D	3-4	120-265D	4-10	122-250H	5-22
113-488D	8-8	118-596D	11-2	120-265D	4-8	122-257H	5-14
113-491D	8-2	118-597D	11-2	120-269S	4-10	122-257H	5-6

Part Number Index

<u>Part Number</u>	<u>Page</u>	<u>Part Number</u>	<u>Page</u>	<u>Part Number</u>	<u>Page</u>	<u>Part Number</u>	<u>Page</u>
122-258H	5-6	188-006V	4-10	198-947H	5-10	402-149H	3-2
123-491D	13-4	188-006V	4-8	198-947H	5-2	402-242D	12-10
123-492D	13-4	188-008V	5-22	198-948H	5-10	402-242D	12-12
123-517D	13-6	195-172H	4-12	198-948H	5-2	402-242D	13-6
123-518D	13-6	195-172H	4-14	198-949H	5-10	402-242D	4-12
123-520D	13-2	196-249S	12-10	198-949H	5-2	402-242D	4-14
123-803L	13-2	197-089D	2-8	198-956K	5-14	402-282D	3-2
123-803L	13-4	197-096D	2-8	198-998S	5-14	403-053D	3-2
123-804L	13-2	198-057S	5-14	198-999S	5-14	403-054D	3-2
123-804L	13-4	198-137D	6-16	199-009S	6-14	403-055D	3-2
129BXT800	5-16	198-137D	6-2	199-011D	6-10	403-056D	3-2
129BXT810	5-16	198-137D	6-20	199-011D	6-12	403-057D	3-2
129BXT811	5-16	198-137D	6-4	199-011D	6-14	403-058D	3-2
133-057D	13-6	198-137D	6-6	199-011D	6-18	403-059D	5-10
133-058D	13-6	198-183D	5-14	199-011D	6-22	403-059D	5-12
133-059D	13-6	198-201D	5-14	199-011D	6-8	403-059D	5-2
133-060D	12-6	198-202D	5-14	199-015D	6-12	403-059D	5-4
133-060D	13-2	198-239D	5-10	199-022H	6-6	403-060D	3-2
133-061D	13-4	198-239D	5-12	199-024H	6-10	403-061D	3-2
133-062D	13-4	198-239D	5-2	199-025H	6-18	403-064D	3-2
133-064D	12-2	198-239D	5-4	199-025H	6-22	403-066D	3-2
133-064D	12-4	198-240D	5-10	199-025H	6-8	403-068D	3-2
133-064D	12-6	198-240D	5-12	199-026H	6-14	403-070D	3-2
133-064D	13-10	198-241D	5-14	199-027H	6-12	403-071D	3-2
133-064D	13-8	198-241D	5-6	199-036D	6-10	403-076D	3-2
133-175K	13-4	198-241D	5-8	199-036D	6-8	403-077D	3-2
133-188H	13-10	198-246D	5-10	199-039H	6-20	403-078D	3-2
133-192V	12-2	198-246D	5-12	199-039H	6-22	403-081D	3-2
133-192V	12-4	198-246D	5-2	199-040H	6-20	403-082D	3-2
133-192V	12-6	198-246D	5-4	199-040H	6-22	403-083D	3-2
133-192V	13-10	198-247D	5-10	199-041S	6-20	403-085D	3-2
133-192V	13-8	198-247D	5-12	199-041S	6-22	403-086D	3-2
133-193H	13-8	198-248D	5-14	199-042D	6-2	403-088D	3-2
136-035D	4-12	198-254D	5-10	199-042D	6-4	403-090D	3-2
136-035D	4-14	198-254D	5-2	199-042S	6-20	403-091D	3-2
136-058D	4-12	198-257D	5-12	199-042S	6-22	403-094D	3-2
136-058D	4-14	198-257D	5-4	199-050D	6-10	403-095D	3-2
136-093D	13-4	198-263D	5-20	199-050D	6-14	403-096D	3-2
136-113D	12-12	198-264D	5-20	199-050D	6-18	403-097D	3-2
136-150D	4-10	198-265D	5-14	199-050D	6-22	403-098D	3-2
136-150D	4-8	198-266D	5-14	199-050D	6-8	403-104K	5-10
136-152D	13-4	198-267D	5-14	1M6006	8-10	403-104K	5-12
136-152D	13-6	198-497H	5-14	248-251D	2-4	403-104K	5-2
136-157D	14-2	198-613H	5-10	298-324S	5-14	403-104K	5-4
136-159D	5-10	198-613H	5-12	2A0006	8-10	403-142D	3-2
136-159D	5-12	198-613H	5-2	2A0012	8-10	405-031D	6-18
136-159D	5-2	198-613H	5-4	2A0022	8-10	405-031D	6-20
136-159D	5-4	198-614H	5-10	2A0132	8-10	405-031D	6-22
136-160D	5-10	198-614H	5-12	2A0206	8-10	405-031D	6-6
136-160D	5-12	198-614H	5-2	2M2326	8-10	466820134S1	10-4
136-160D	5-2	198-614H	5-4	313-076S	2-6	466820134S1	10-6
136-160D	5-4	198-615H	5-14	313-176D	2-6	466820134S1	10-8
136-174D	4-12	198-616H	5-6	313-186D	2-6	466820835S1	10-4
136-174D	4-14	198-616H	5-8	3M2310	8-10	466820835S1	10-6
136-184D	12-10	198-618H	5-10	402-022H	12-10	466820835S1	10-8
136-184D	12-10	198-618H	5-12	402-022H	12-12	466822000S1	10-4
136-187D	12-12	198-618H	5-2	402-025S	14-2	466822000S1	10-6
136-188D	13-6	198-618H	5-4	402-025S	4-12	466822000S1	10-8
150-138D	2-4	198-619H	5-10	402-025S	4-14	467751130S1	10-4
150GP022E	5-16	198-619H	5-12	402-058D	14-2	467751130S1	10-6
173-107D	2-10	198-619H	5-2	402-126H	12-10	467751130S1	10-8
173-109H	2-10	198-619H	5-4	402-126H	12-12	467751200S1	10-4
173-109H	2-12	198-738S	5-14	402-126H	4-12	467751200S1	10-6
175-177S	13-4	198-738S	5-6	402-126H	4-14	467751206S1	10-4
175-178S	13-4	198-738S	5-8	402-140S	12-12	467751206S1	10-6
188-001V	5-14	198-810H	2-10	402-140S	13-6	467751206S1	10-8
188-001V	5-6	198-810H	2-12	402-140S	4-12	467751410S1	10-6
188-001V	5-8	198-810H	2-14	402-140S	4-14	467751411S1	10-6

Part Number Index

<u>Part Number</u>	<u>Page</u>	<u>Part Number</u>	<u>Page</u>	<u>Part Number</u>	<u>Page</u>	<u>Part Number</u>	<u>Page</u>
467751430S1	10-4	801-141C	5-22	802-082C	4-10	802-421C	6-20
467751431S1	10-4	801-151C	2-4	802-082C	4-8	802-421C	6-4
467751432S1	10-8	801-154C	2-8	802-091C	12-2	802-421C	6-6
4M2102	8-10	801-160C	3-2	802-091C	12-4	802-424C	4-12
5M2128	8-10	802-002C	5-10	802-091C	13-6	802-425C	2-6
6M2170	8-10	802-002C	5-2	802-091C	14-2	802-430C	5-14
7M2328	8-10	802-004C	10-2	802-091C	2-12	802-453C	12-12
800-001C	4-2	802-004C	14-4	802-091C	2-14	802-453C	13-6
800-001C	4-4	802-004C	2-4	802-092C	2-4	802-551C	14-4
800-001C	4-6	802-005C	6-10	802-092C	5-14	802-617C	5-16
800-001C	5-14	802-005C	6-16	802-099C	12-10	802-617C	6-2
800-001C	8-2	802-005C	6-18	802-099C	12-12	802-618C	6-4
800-029C	12-2	802-005C	6-6	802-099C	8-2	802-620C	5-10
800-029C	12-4	802-005C	6-8	802-114C	5-12	802-620C	5-2
800-029C	12-4	802-009C	4-12	802-114C	5-4	802-672C	14-2
800-029C	12-6	802-009C	4-14	802-115C	8-2	802-672C	4-12
800-029C	12-6	802-014C	8-8	802-130C	12-12	802-672C	4-14
800-029C	13-10	802-017C	2-10	802-135C	4-4	802-694C	5-14
800-029C	13-8	802-017C	2-12	802-135C	4-6	802-705C	4-8
800-038C	4-10	802-017C	2-12	802-138C	9-2	802-705C	5-20
800-038C	4-8	802-017C	2-14	802-149C	5-20	802-729C	5-14
800-046C	3-2	802-017C	2-6	802-159C	3-2	803-001C	2-8
800-054C	6-20	802-017C	5-10	802-160C	6-10	803-004C	2-12
800-054C	6-22	802-017C	5-12	802-160C	6-8	803-006C	10-2
800-060C	2-2	802-017C	5-2	802-196C	6-12	803-006C	12-6
800-064C	12-6	802-017C	5-4	802-196C	6-14	803-006C	13-2
800-082C	8-6	802-022C	12-10	802-199C	12-10	803-008C	12-10
800-085C	3-2	802-022C	2-10	802-201C	4-14	803-008C	13-6
800-093C	5-22	802-022C	2-12	802-203C	13-4	803-008C	3-2
800-104C	3-4	802-022C	5-22	802-203C	2-4	803-011C	2-4
800-118C	5-14	802-022C	9-2	802-228C	5-14	803-011C	2-6
800-121C	2-6	802-029C	6-10	802-228C	5-6	803-011C	4-8
800-213C	5-14	802-029C	6-12	802-228C	5-8	803-011C	8-2
800-213C	5-6	802-029C	6-14	802-249C	8-2	803-012C	6-14
800-213C	5-8	802-029C	6-18	802-252C	12-10	803-013C	2-12
800-269C	14-2	802-029C	6-22	802-252C	4-12	803-013C	5-16
800-300C	8-6	802-029C	6-8	802-252C	4-14	803-013C	8-2
800-300C	8-8	802-034C	13-4	802-253C	8-2	803-013C	9-2
800-303C	5-10	802-034C	2-2	802-254C	8-2	803-014C	12-10
800-303C	5-12	802-034C	8-8	802-258C	4-2	803-014C	12-10
800-303C	5-2	802-039C	9-2	802-258C	4-4	803-014C	12-10
800-303C	5-4	802-041C	8-2	802-258C	4-6	803-014C	12-12
800-311C	3-4	802-055C	4-10	802-258C	5-10	803-014C	12-12
800-319C	3-2	802-058C	4-8	802-258C	5-12	803-014C	12-6
800-321C	12-2	802-058C	6-12	802-258C	5-2	803-014C	13-4
800-321C	12-4	802-058C	6-16	802-258C	5-4	803-014C	13-6
800-321C	12-6	802-058C	6-2	802-259C	12-10	803-014C	2-10
800-321C	13-4	802-058C	6-4	802-281C	13-6	803-014C	2-12
800-323C	12-2	802-059C	2-2	802-282C	12-12	803-014C	2-14
800-323C	12-6	802-059C	6-18	802-282C	13-6	803-014C	5-16
801-002C	12-2	802-059C	6-20	802-282C	14-2	803-014C	5-18
801-002C	12-4	802-059C	6-22	802-315C	3-2	803-014C	5-22
801-002C	12-6	802-059C	6-6	802-352C	5-14	803-014C	5-6
801-002C	13-10	802-078C	4-2	802-366C	5-14	803-014C	5-8
801-002C	13-8	802-078C	4-4	802-387C	2-4	803-017C	4-2
801-007C	6-14	802-078C	4-6	802-388C	13-2	803-017C	4-4
801-018C	12-6	802-079C	12-12	802-388C	13-4	803-017C	4-6
801-018C	13-2	802-079C	12-6	802-388C	2-10	803-019C	2-12
801-035C	14-2	802-079C	2-10	802-388C	2-14	803-019C	2-14
801-035C	4-12	802-079C	2-12	802-388C	2-4	803-019C	4-2
801-035C	4-14	802-079C	2-14	802-411C	2-6	803-019C	4-4
801-054C	8-2	802-079C	2-4	802-411C	5-16	803-019C	4-6
801-059C	4-2	802-079C	5-18	802-419C	5-10	803-019C	5-10
801-059C	4-4	802-079C	5-6	802-419C	5-12	803-019C	5-2
801-059C	4-6	802-079C	5-8	802-419C	5-2	803-019C	8-2
801-078C	5-22	802-079C	9-2	802-419C	5-4	803-020C	12-10
801-084C	5-22	802-082C	14-2	802-421C	6-16	803-020C	12-12
801-096C	2-8	802-082C	14-2	802-421C	6-2	803-020C	12-12

Part Number Index

<u>Part Number</u>	<u>Page</u>	<u>Part Number</u>	<u>Page</u>	<u>Part Number</u>	<u>Page</u>	<u>Part Number</u>	<u>Page</u>
803-020C	12-2	803-169C	6-20	804-012C	9-2	804-022C	13-6
803-020C	12-4	803-169C	6-4	804-013C	12-10	804-022C	2-2
803-020C	12-6	803-169C	6-6	804-013C	12-10	804-022C	5-10
803-020C	13-4	803-177C	12-12	804-013C	12-10	804-022C	5-12
803-020C	13-6	803-177C	14-2	804-013C	12-12	804-022C	5-14
803-020C	14-2	803-177C	4-12	804-013C	12-12	804-022C	5-2
803-020C	2-10	803-177C	4-14	804-013C	12-6	804-022C	5-4
803-020C	2-12	803-194C	5-10	804-013C	13-4	804-022C	6-10
803-020C	2-14	803-194C	5-2	804-013C	13-6	804-022C	6-12
803-020C	2-2	803-198C	5-10	804-013C	2-10	804-022C	6-16
803-020C	2-2	803-198C	5-2	804-013C	2-12	804-022C	6-18
803-020C	4-10	803-199C	2-4	804-013C	2-14	804-022C	6-18
803-020C	4-8	803-208C	4-2	804-013C	2-4	804-022C	6-2
803-020C	8-2	803-209C	12-12	804-013C	5-16	804-022C	6-20
803-020C	8-2	803-209C	13-2	804-013C	5-18	804-022C	6-22
803-020C	8-8	803-209C	13-6	804-013C	5-22	804-022C	6-4
803-020C	9-2	803-209C	2-10	804-013C	5-6	804-022C	6-6
803-021C	12-10	803-209C	2-10	804-013C	5-8	804-022C	6-8
803-021C	13-6	803-209C	2-14	804-013C	8-8	804-022C	8-2
803-021C	2-2	803-209C	2-4	804-014C	5-14	804-023C	4-12
803-021C	5-10	803-209C	2-6	804-014C	6-10	804-023C	4-14
803-021C	5-12	803-209C	4-12	804-014C	6-12	804-024C	4-10
803-021C	5-2	803-209C	4-14	804-014C	6-14	804-024C	4-8
803-021C	5-4	803-209C	5-10	804-014C	6-18	804-025C	8-4
803-021C	6-10	803-209C	5-12	804-014C	6-22	804-029C	8-2
803-021C	6-18	803-209C	5-2	804-014C	6-8	804-036C	2-6
803-021C	6-22	803-209C	5-20	804-015C	12-10	804-036C	4-8
803-021C	6-8	803-209C	5-4	804-015C	12-12	804-040C	5-14
803-021C	8-2	803-229C	3-2	804-015C	12-12	804-040C	5-6
803-023C	4-2	803-229C	6-10	804-015C	12-2	804-040C	5-8
803-023C	4-4	803-229C	6-12	804-015C	12-4	804-041C	6-10
803-023C	4-6	803-229C	6-14	804-015C	12-6	804-041C	6-12
803-024C	8-2	803-229C	6-18	804-015C	13-4	804-041C	6-14
803-027C	4-12	803-229C	6-22	804-015C	13-6	804-041C	6-18
803-027C	4-14	803-229C	6-8	804-015C	14-2	804-041C	6-22
803-036C	4-12	803-239C	4-2	804-015C	2-10	804-041C	6-8
803-036C	4-14	803-239C	4-4	804-015C	2-12	804-061C	12-12
803-036C	8-2	803-239C	4-6	804-015C	2-14	804-061C	4-10
803-043C	5-14	803-255C	2-8	804-015C	2-2	804-061C	4-12
803-046C	4-10	803-293C	2-4	804-015C	2-2	804-061C	4-14
803-046C	4-8	803-302C	3-2	804-015C	4-10	804-061C	4-8
803-053C	8-4	803-307C	5-14	804-015C	4-12	804-075C	2-8
803-078C	2-10	804-004C	2-8	804-015C	4-14	804-078C	5-22
803-078C	2-12	804-006C	10-2	804-015C	4-8	804-098C	4-2
803-084C	9-2	804-006C	12-6	804-015C	8-2	804-111C	3-2
803-088C	14-4	804-006C	13-2	804-015C	8-8	804-113C	14-2
803-088C	6-10	804-006C	4-2	804-015C	9-2	804-113C	4-12
803-088C	6-12	804-006C	4-4	804-016C	12-6	804-182C	4-2
803-088C	6-14	804-006C	4-6	804-016C	13-6	804-182C	4-4
803-088C	6-16	804-007C	10-2	804-016C	14-2	804-182C	4-6
803-088C	6-18	804-007C	3-2	804-016C	2-12	804-195C	5-14
803-088C	6-2	804-007C	4-2	804-016C	2-14	805-019C	8-4
803-088C	6-4	804-007C	4-4	804-016C	4-12	805-020C	5-22
803-088C	6-6	804-007C	4-6	804-016C	5-10	805-024C	13-6
803-088C	6-8	804-009C	12-10	804-016C	5-2	805-032C	2-10
803-147C	9-2	804-009C	13-6	804-017C	12-10	805-032C	2-12
803-148C	4-10	804-009C	3-2	804-017C	12-10	805-032C	2-14
803-148C	4-8	804-009C	5-20	804-017C	12-12	805-045C	4-10
803-159C	8-4	804-010C	9-2	804-017C	12-12	805-045C	4-8
803-169C	12-12	804-011C	2-10	804-017C	12-2	805-058C	2-2
803-169C	13-4	804-011C	2-12	804-017C	12-4	805-058C	8-2
803-169C	2-4	804-011C	2-14	804-017C	14-2	805-062C	5-14
803-169C	5-10	804-011C	2-4	804-017C	2-10	805-063C	4-10
803-169C	5-12	804-011C	2-6	804-017C	4-14	805-063C	4-8
803-169C	5-2	804-011C	5-22	804-017C	4-14	805-063C	5-14
803-169C	5-4	804-012C	2-10	804-017C	8-2	805-063C	5-6
803-169C	6-16	804-012C	2-12	804-021C	8-2	805-063C	5-8
803-169C	6-2	804-012C	5-14	804-022C	12-10	805-063C	6-22

Part Number Index

<u>Part Number</u>	<u>Page</u>	<u>Part Number</u>	<u>Page</u>	<u>Part Number</u>	<u>Page</u>	<u>Part Number</u>	<u>Page</u>
805-064C	12-10	805-304C	6-18	808-149C	4-12	812-309C	5-14
805-064C	12-12	805-304C	6-22	808-149C	4-14	812-309C	5-8
805-064C	4-12	805-304C	6-8	808-150C	4-12	814-005C	4-2
805-064C	4-14	805-307C	3-2	808-150C	4-14	814-005C	4-4
805-067C	2-8	805-335C	5-14	808-151C	12-10	814-005C	4-6
805-067C	4-2	805-335C	5-8	808-151C	12-12	814-026C	4-2
805-067C	4-4	806-001C	12-6	808-151C	4-10	814-026C	4-4
805-067C	4-6	806-004C	12-10	808-151C	4-12	814-026C	4-6
805-067C	5-14	806-004C	12-12	808-151C	4-14	814-034C	6-10
805-067C	6-10	806-005C	2-10	808-151C	4-8	814-034C	6-6
805-067C	6-12	806-005C	2-12	808-152C	4-12	814-034C	6-8
805-067C	6-14	806-005C	2-14	808-152C	4-14	814-081C	5-14
805-067C	6-18	806-046C	9-2	808-153C	12-10	814-082C	5-14
805-067C	6-8	806-053C	5-10	808-153C	12-12	814-083C	5-14
805-069C	5-22	806-053C	5-12	808-153C	4-12	814-084C	6-14
805-077C	2-2	806-053C	5-2	808-153C	4-14	814-085C	6-12
805-080C	3-2	806-053C	5-4	808-154C	12-10	814-085C	6-14
805-098C	4-2	806-053C	8-2	808-154C	12-12	814-157C	6-2
805-098C	4-4	806-092C	12-2	808-154C	4-12	814-158C	6-4
805-098C	4-6	806-092C	12-4	808-154C	4-14	814-159C	6-2
805-125C	4-2	806-121C	4-12	808-155C	4-12	814-160C	6-4
805-125C	4-4	806-121C	4-14	808-155C	4-12	814-174C	6-10
805-125C	4-6	806-122C	12-6	808-155C	4-14	814-174C	6-6
805-127C	2-12	806-122C	14-2	808-155C	4-14	814-174C	6-8
805-127C	2-14	806-122C	8-2	808-156C	12-12	814-192C	6-12
805-143C	2-12	806-122C	9-2	808-156C	4-12	814-194C	6-12
805-143C	2-14	806-159C	14-2	808-156C	4-14	814-238C	6-16
805-146C	3-2	806-163C	12-6	808-156C	4-8	814-238C	6-18
805-148C	4-2	806-163C	2-2	808-168C	13-6	814-244C	6-16
805-148C	4-4	806-165C	12-12	808-219C	12-10	814-244C	6-18
805-148C	4-6	806-165C	13-6	808-219C	13-6	815-001C	8-4
805-154C	6-16	806-166C	13-4	808-219C	14-2	816-012C	4-2
805-154C	6-2	806-166C	2-14	808-223C	12-10	816-012C	4-4
805-154C	6-20	806-168C	12-6	808-223C	12-12	816-012C	4-6
805-154C	6-4	807-076C	5-10	808-224C	12-10	816-014C	8-4
805-154C	6-6	807-076C	5-12	808-224C	12-12	816-035C	4-2
805-166C	6-12	807-079C	9-2	808-251C	12-10	816-035C	4-4
805-179C	2-2	807-088C	6-12	808-251C	12-12	816-035C	4-6
805-180C	12-10	807-088C	6-14	808-251C	14-2	816-138C	4-2
805-180C	12-12	807-088C	6-18	808-275C	4-2	816-138C	4-4
805-180C	14-2	807-088C	6-22	808-275C	4-4	816-138C	4-6
805-180C	4-10	807-088C	6-8	808-275C	4-6	816-173C	5-22
805-180C	4-12	807-101C	5-22	808-276C	4-10	816-302C	5-14
805-180C	4-14	807-106C	2-6	808-276C	4-8	816-302C	5-6
805-180C	4-8	807-106C	6-16	808-277C	3-2	816-302C	5-8
805-182C	3-2	807-106C	6-2	809-070C	14-2	816-331C	3-4
805-186C	6-16	807-106C	6-20	810-187C	8-10	816-332C	3-2
805-186C	6-2	807-106C	6-4	810-058C	8-6	816-358C	13-4
805-186C	6-20	807-106C	6-6	810-197C	8-8	816-366C	11-2
805-186C	6-4	807-116C	5-10	810-205C	8-2	816-369C	11-2
805-186C	6-6	807-116C	5-12	811-044C	8-6	816-383C	5-6
805-232C	2-2	807-116C	5-2	811-063C	14-4	816-383C	5-8
805-240C	12-10	807-116C	5-4	811-088C	14-4	816-414C	5-14
805-240C	12-12	807-172C	5-14	811-129C	8-6	817-025C	4-2
805-240C	4-12	807-184C	6-10	811-129C	8-8	817-025C	4-4
805-240C	4-14	807-185C	3-2	811-169C	8-8	817-025C	4-6
805-280C	5-14	807-186C	3-2	811-192C	14-4	817-042C	2-4
805-280C	5-6	807-187C	3-2	811-205C	14-4	817-083C	3-2
805-295C	6-10	807-188C	5-22	811-281C	8-6	817-083C	5-14
805-296C	3-2	807-194C	3-2	811-281C	8-8	817-084C	5-10
805-296C	4-10	808-046C	12-10	811-281C	8-8	817-084C	5-12
805-296C	4-8	808-046C	13-6	811-297C	8-8	817-084C	5-2
805-296C	5-14	808-147C	4-10	811-440C	8-8	817-084C	5-4
805-298C	3-2	808-147C	4-8	811-564C	14-4	817-084C	6-16
805-299C	5-6	808-148C	12-10	812-297C	5-14	817-084C	6-2
805-299C	5-8	808-148C	4-12	812-297C	5-6	817-084C	6-20
805-302C	3-2	808-148C	4-14	812-298C	5-6	817-084C	6-4
805-304C	6-14	808-149C	12-12	812-302C	5-14	817-084C	6-6

Part Number Index

<u>Part Number</u>	<u>Page</u>	<u>Part Number</u>	<u>Page</u>	<u>Part Number</u>	<u>Page</u>	<u>Part Number</u>	<u>Page</u>
817-086C	2-8	818-207C	13-12	833-198C	10-8	890-598C	6-18
817-134C	5-22	818-229C	7-2	833-199C	10-4	890-598C	6-22
817-136C	12-4	818-229C	8-2	833-199C	10-6	890-598C	6-8
817-202C	2-8	818-230C	7-2	833-199C	10-8	890-600C	2-2
817-296C	6-2	818-245C	13-12	833-200C	10-2	890-614C	8-4
817-297C	6-4	818-337C	7-2	833-200C	14-2	890-640C	2-2
817-328C	6-16	818-339C	7-2	833-200C	14-6	890-673C	13-6
817-328C	6-2	818-398C	7-2	833-222C	5-14	890-673C	4-8
817-328C	6-20	818-587C	7-2	833-222C	5-6	890-750C	11-2
817-328C	6-4	818-590C	7-2	833-222C	5-8	900TUBEBL	5-16
817-328C	6-6	818-682C	8-2	833-223C	10-2	AD21010	5-6
817-330C	6-10	818-751C	7-2	833-224C	10-2	AD21010	5-8
817-330C	6-16	820-094C	8-4	833-225C	10-2	AD21011	5-6
817-330C	6-18	820-155C	5-14	838-102C	7-2	AD21011	5-8
817-330C	6-6	820-155C	5-6	838-122C	7-2	AD21012	5-6
817-330C	6-8	820-256C	5-14	838-123C	7-2	AD21012	5-8
817-347C	6-16	820-256C	5-8	838-124C	7-2	AD21013	5-6
817-347C	6-2	821-046C	2-4	838-125C	7-2	AD21013	5-8
817-347C	6-20	822-023C	6-14	838-126C	13-12	AD21014	5-6
817-347C	6-4	822-030C	8-4	838-126C	7-2	AD21014	5-8
817-347C	6-6	822-032C	13-6	838-127C	13-12	B0-47	8-4
817-348C	8-6	822-032C	4-8	838-127C	7-2	VER-18360	14-4
817-348C	8-8	822-080C	8-4	838-130C	7-2	VER-18360	14-6
817-349C	5-14	822-095C	5-14	838-131C	7-2	VER-18363	14-6
817-349C	5-6	822-117C	4-2	838-132C	7-2	VER-18375	14-4
817-349C	5-8	822-117C	4-4	838-134C	7-2	VER-18375	14-6
817-350C	2-8	822-117C	4-6	838-135C	7-2	VER-18376	14-6
817-396C	5-14	822-118C	4-2	838-139C	7-2	VER-18377	14-6
817-396C	5-6	822-118C	4-4	838-153C	7-2	VER-18382	14-4
817-396C	5-8	822-118C	4-6	838-157C	7-2	VER-18382	14-6
817-400C	3-4	822-119C	13-6	838-160C	13-12	VER-18468	14-2
817-402C	3-2	822-119C	14-2	838-160C	7-2	VER-18468	14-4
817-403C	3-2	822-119C	4-12	838-161C	13-12	VER-18548	14-4
817-404C	3-2	822-119C	4-14	838-161C	7-2	VER-18574	14-4
817-405C	3-2	822-119C	4-8	838-228C	7-2	VER-18577	14-4
817-406C	12-12	822-170C	3-2	838-237C	2-8	VER-19516	14-6
817-406C	13-6	822-170C	6-10	838-237C	7-2	VER-19517	14-2
817-406C	14-2	822-170C	6-12	838-265C	7-2	VER-19517	14-4
817-406C	3-2	822-170C	6-16	838-266C	12-6	VER-19554	14-4
817-406C	4-12	822-170C	6-18	838-266C	7-2	VER-19579	14-6
817-406C	4-14	822-170C	6-2	838-267C	12-6	VER-19620	14-4
817-407C	3-2	822-170C	6-20	838-267C	7-2	VER-19621	14-4
817-413C	5-14	822-170C	6-22	838-273C	7-2	VER-19625	14-4
817-413C	5-6	822-170C	6-4	838-352C	7-2	VER-19626	14-4
817-413C	5-8	822-170C	6-6	838-400C	7-2	VER-19676	14-6
817-456C	12-10	822-170C	6-8	838-452C	7-2	VER-19677	14-6
817-464C	12-2	822-175C	12-10	838-467C	13-12	VER-19679	14-6
817-464C	12-6	822-175C	12-12	838-617C	7-2	VER-19683	14-6
817-465C	12-4	822-175C	14-2	890-005C	8-2	VER-19729	14-6
817-465C	12-6	822-175C	4-12	890-221C	2-6	VER-19798	14-4
817-466C	11-2	822-175C	4-14	890-305C	2-8	VER-19799	14-4
817-474C	11-2	822-195C	12-10	890-311C	2-4	VER-19800	14-4
817-475C	11-2	822-195C	12-12	890-312C	2-4	VER-19856	14-4
817-480C	5-10	826-350C	14-2	890-351C	9-2	VER-20129	14-4
817-480C	5-12	833-169C	10-2	890-357C	5-18	VER-20317	14-2
817-480C	5-2	833-183C	10-2	890-390C	2-2	VER-21567	14-6
817-480C	5-4	833-189C	10-2	890-466C	5-14	VER-21568	14-4
817-481C	12-2	833-195C	10-4	890-466C	5-6	VER-5211	14-4
817-481C	12-4	833-195C	10-6	890-466C	5-8		
817-481C	12-6	833-195C	10-8	890-524C	6-10		
817-481C	13-10	833-196C	10-4	890-524C	6-12		
817-481C	13-8	833-196C	10-6	890-524C	6-14		
817-516C	2-4	833-196C	10-8	890-524C	6-18		
817-516C	7-2	833-197C	10-4	890-524C	6-22		
817-529C	3-2	833-197C	10-6	890-524C	6-8		
818-003C	7-2	833-197C	10-8	890-598C	6-10		
818-055C	12-6	833-198C	10-4	890-598C	6-12		
818-055C	13-2	833-198C	10-6	890-598C	6-14		

Box To Frame

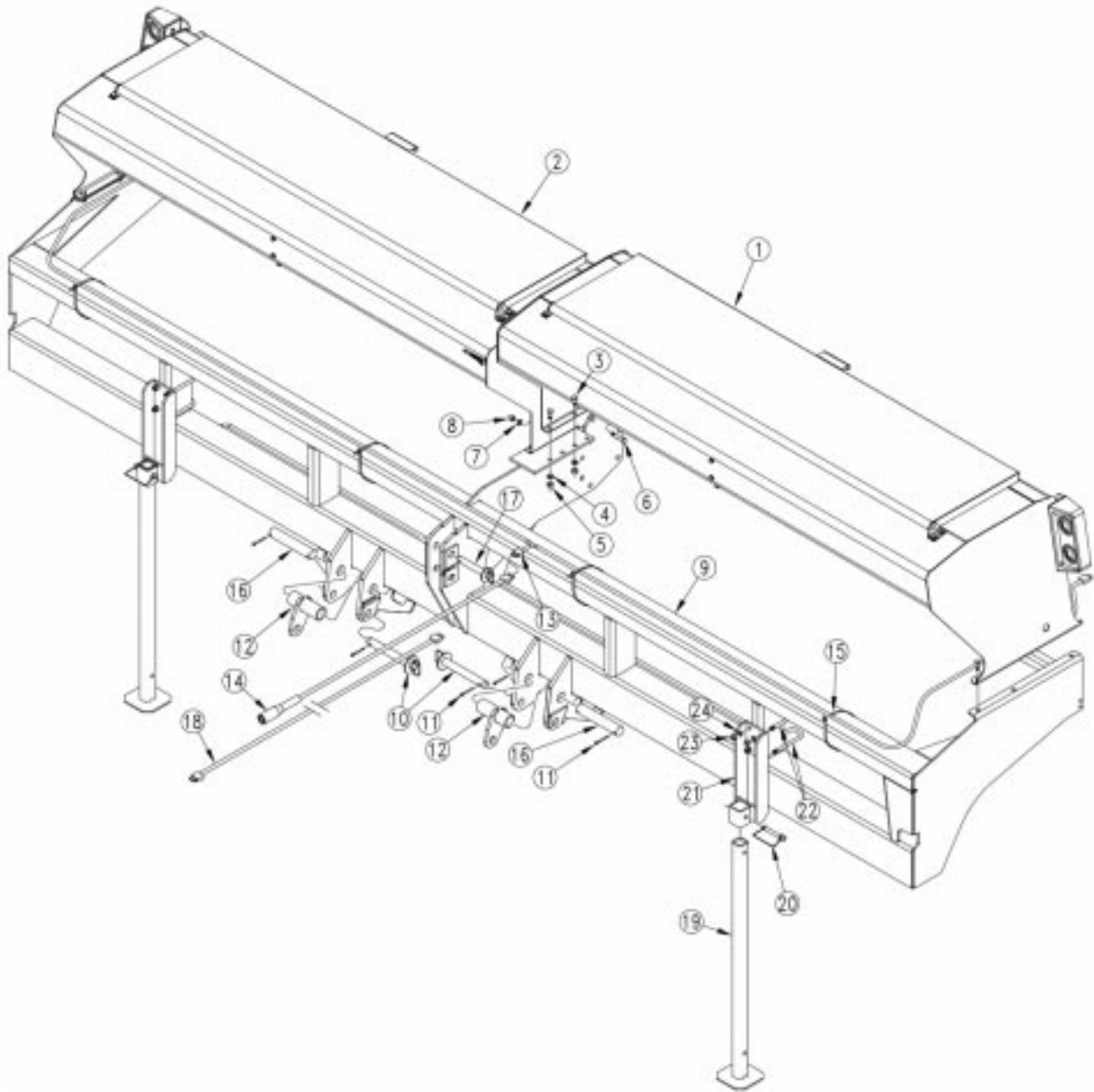

Box To Frame

2

Ref.	Part No.	Part Description	Comments
1.	118-714L	LH 15FT BOX & LID ASSY	
2.	118-716L	RH 15FT BOX & LID ASSY	
3.	802-034C	HHCS 1/2-13X1 1/4 GR5	
4.	804-015C	WASHER LOCK SPRING 1/2 PLT	
5.	803-020C	NUT HEX 1/2-13 PLT	
6.	802-059C	HHCS 5/8-11X3 GR5	
7.	804-022C	WASHER LOCK SPRING 5/8 PLT	
8.	803-021C	NUT HEX 5/8-11 PLT	
9.	117-057H	FRAME, 3PT 15-P	
10.	805-179C	PIN HITCH 1 1/8 X 8 1/2 USABLE	
11.	805-058C	PIN COTTER 3/16 X 2	
12.	117-059H	HITCH PIN SUPPORT INSERT	
13.	890-390C	LIGHT HARNESS, 10' WISHBONE	
14.	890-640C	LIGHT HARNESS, 5' LEAD	
15.	800-060C	CABLE TIE .19X14.25 3DIA 50LB	
16.	117-323D	PIN 1 1/2 X 7 1/4 USEABLE, PLT	
17.	805-077C	PIN HITCH 1 X 4 1/2 USABLE LG	
18.	890-600C	AG LIGHT HARNESS, EXT-15'	
19.	119-281H	STAND WELDMENT	
20.	805-232C	PIN WIRE SNAP LOCK 1/2 X 3 1/2	
21.	119-282H	15P STAND MOUNT	
22.	806-163C	U-BOLT 1/2-13 X 2 1/32 X 6 1/2	
23.	803-020C	NUT HEX 1/2-13 PLT	
24.	804-015C	WASHER LOCK SPRING 1/2 PLT	

Legend: ● = 1st revision; ● = 2nd revision; ● = 3rd revision; ● = use up existing stock; ⊗ = not interchangeable; ⊗ ① ● = for example: revision 2 is not interchangeable w/revision 1

Box Components

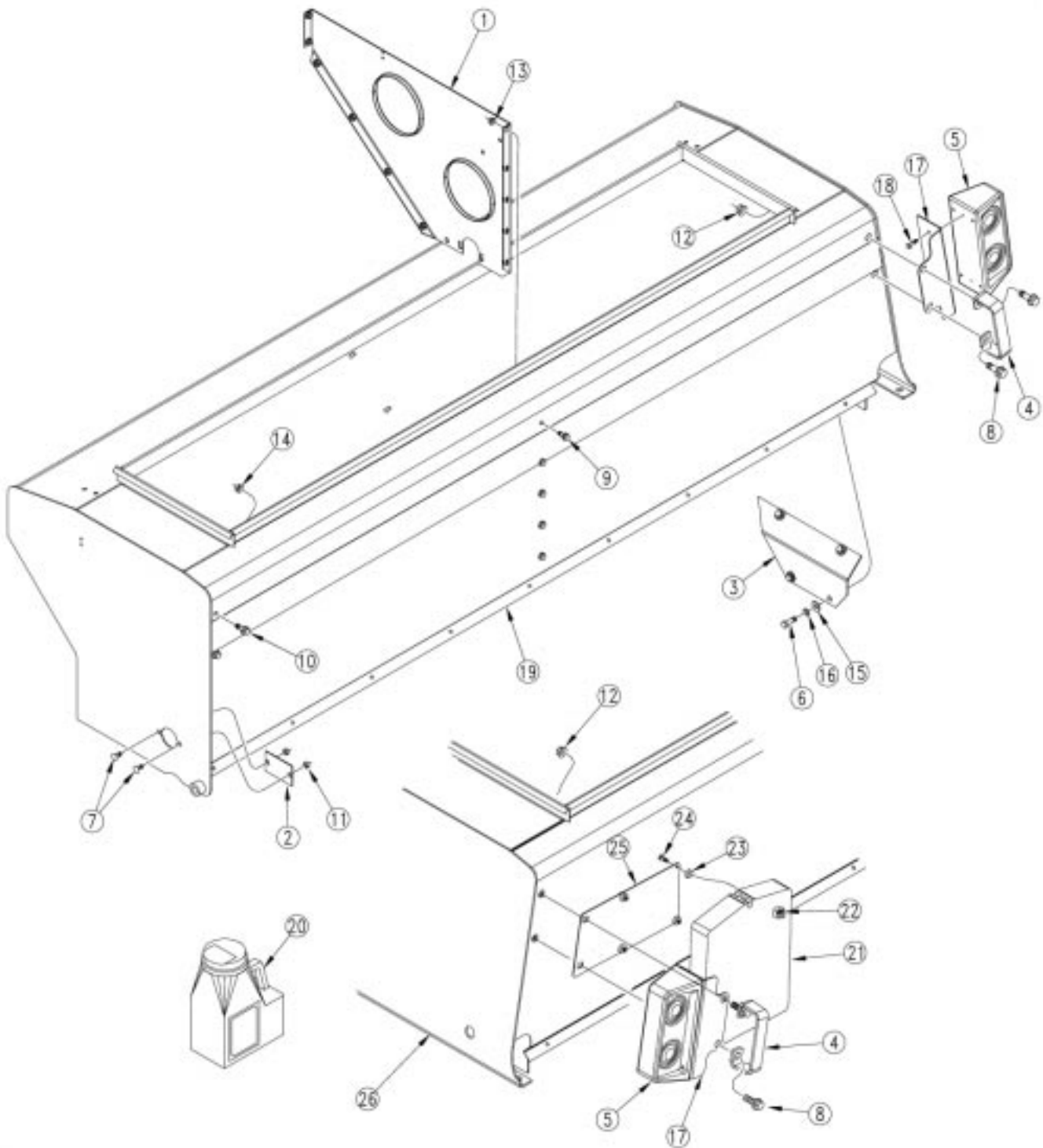

Box Components

Ref.	Part No.	Part Description	Comments
1.	118-402D	SEED BOX PARTITION	
2.	118-403D	BEARING CUTOOUT COVER, 47 MST	
3.	118-487D	SEED BOX IDLER COVER RH	Shown.
	118-486D	SEED BOX IDLER COVER LH	
4.	119-190D	HANDLE	
5.	890-312C	DUAL AG LIGHTS	RH side.
	890-311C	DUAL AG LIGHTS	LH side.
6.	802-079C	HHCS 3/8-16X1 1/4 GR5	
7.	802-092C	RHSNB 5/16-18X3/4 GR5	
8.	802-203C	HFSS 1/2-13X1 1/2 GR5	
9.	802-387C	HFS 5/16-18X3/4 GR5	
10.	802-388C	HFS 3/8-16X1 GR5	
11.	803-011C	NUT LOCK 5/16-18 PLT	
12.	803-169C	NUT HEX FLG. LOCK 1/2-13 PLT.	
13.	803-199C	NUT HEX FLANGE 5/16-18 PLT	
14.	803-209C	NUT FLANGE LOCK 3/8-16 PLT	
15.	804-011C	WASHER FLAT 3/8 USS PLT	
16.	804-013C	WASHER LOCK SPRING 3/8 PLT	
17.	150-138D	12' EWNT LIGHT BRACKET	
18.	801-151C	SCR HEX SELF TAP 1/4-20X1TYPEF	
19.	118-453H	15' SEED BOX RH	
20.	821-046C	TALC LUBRICANT-JUG CONTAINER	
21.	817-516C	MANUAL PAK 1" W/ GASKET	
22.	803-293C	NUT HEX FLANGE LOCK 1/4-20 PLT	
23.	817-042C	MINI END WHEEL PRESS WHEEL	
24.	802-004C	HHCS 1/4-20X3/4 GR5	
25.	248-251D	MANUAL PAK MOUNTING PLATE	
26.	118-414H	15' SEED BOX LH	

Legend: ● = 1st revision; ● = 2nd revision; ● = 3rd revision; ● = use up existing stock; ⊗ = not interchangeable; ⊗ ① ● = for example: revision 2 is not interchangeable w/revision 1

Lid To Box

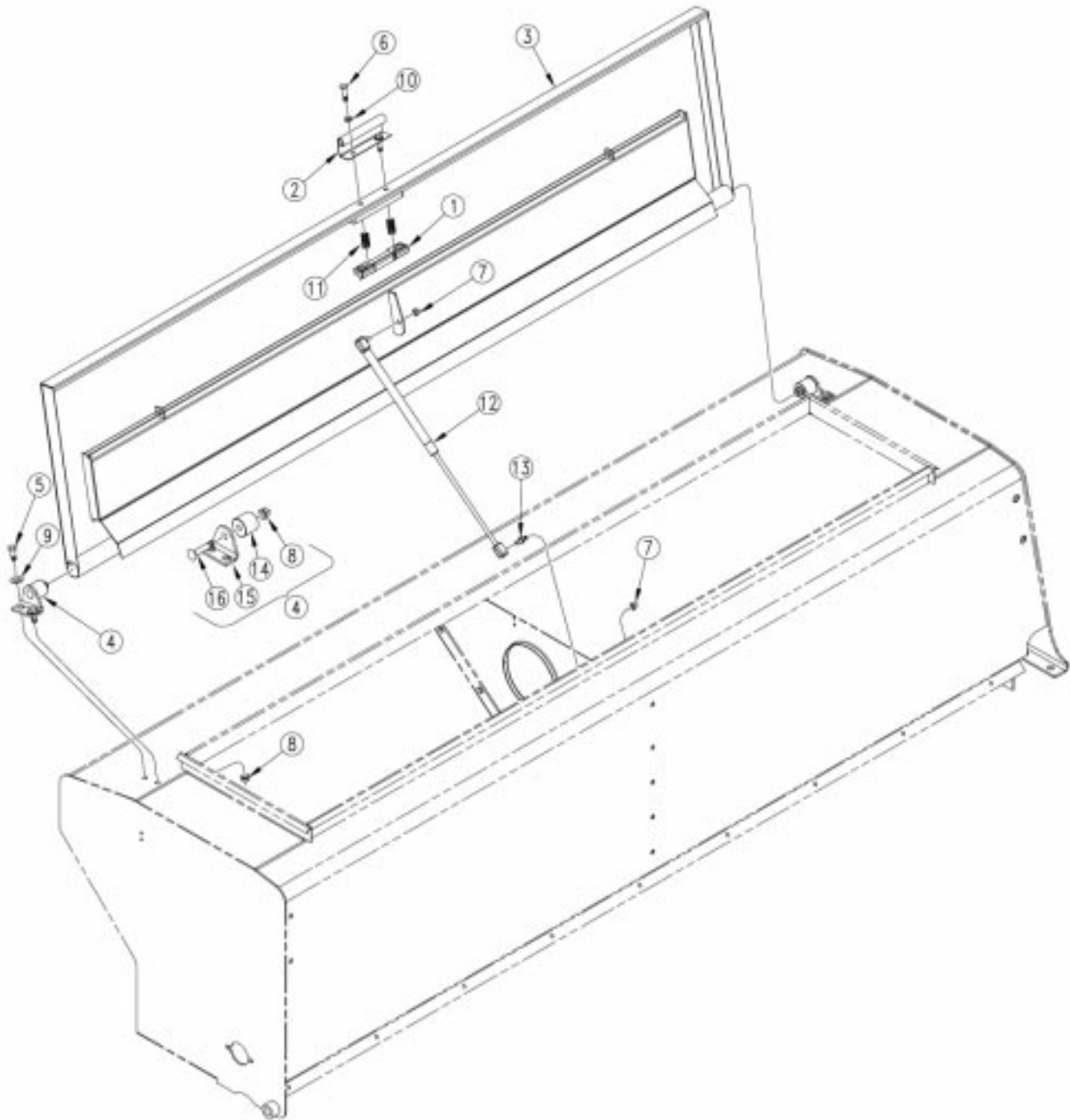

17708



Lid To Box

Ref.	Part No.	Part Description	Comments
1.	119-153D	LATCH CASTING MACHINED	
2.	119-154D	LID HANDLE	
3.	119-230H	LID 76 7/8 SEED	
4.	313-076S	LID HINGE ASSEMBLY PS25120	Inciudes 8,14,15 & 16
5.	802-017C	HHCS 3/8-16X1 GR5	
6.	802-425C	HHCS 5/16-18X1 1/4 NYL	
7.	803-011C	NUT LOCK 5/16-18 PLT	
8.	803-209C	NUT FLANGE LOCK 3/8-16 PLT	
9.	804-011C	WASHER FLAT 3/8 USS PLT	
10.	804-036C	WASHER FLAT 5/16 SAE PLT	
11.	807-106C	SPRING .540 O.D.X 1 1/4 X.054W	
12.	890-221C	12-20 x 90 LB GAS SPRING	
13.	800-121C	BALL STUD 10MM X 5/16-18 UNC	
14.	313-186D	LID HINGE PIVOT	
15.	313-176D	LID HINGE BASE PLATE	
16.	802-411C	RHSNB 3/8-16X2 GR5	

Legend: ● = 1st revision; ● = 2nd revision; ● = 3rd revision; ● = use up existing stock; ⊗ = not interchangeable; ⊗ ① ● = for example: revision 2 is not interchangeable w/revision 1

Seed Level Indicator

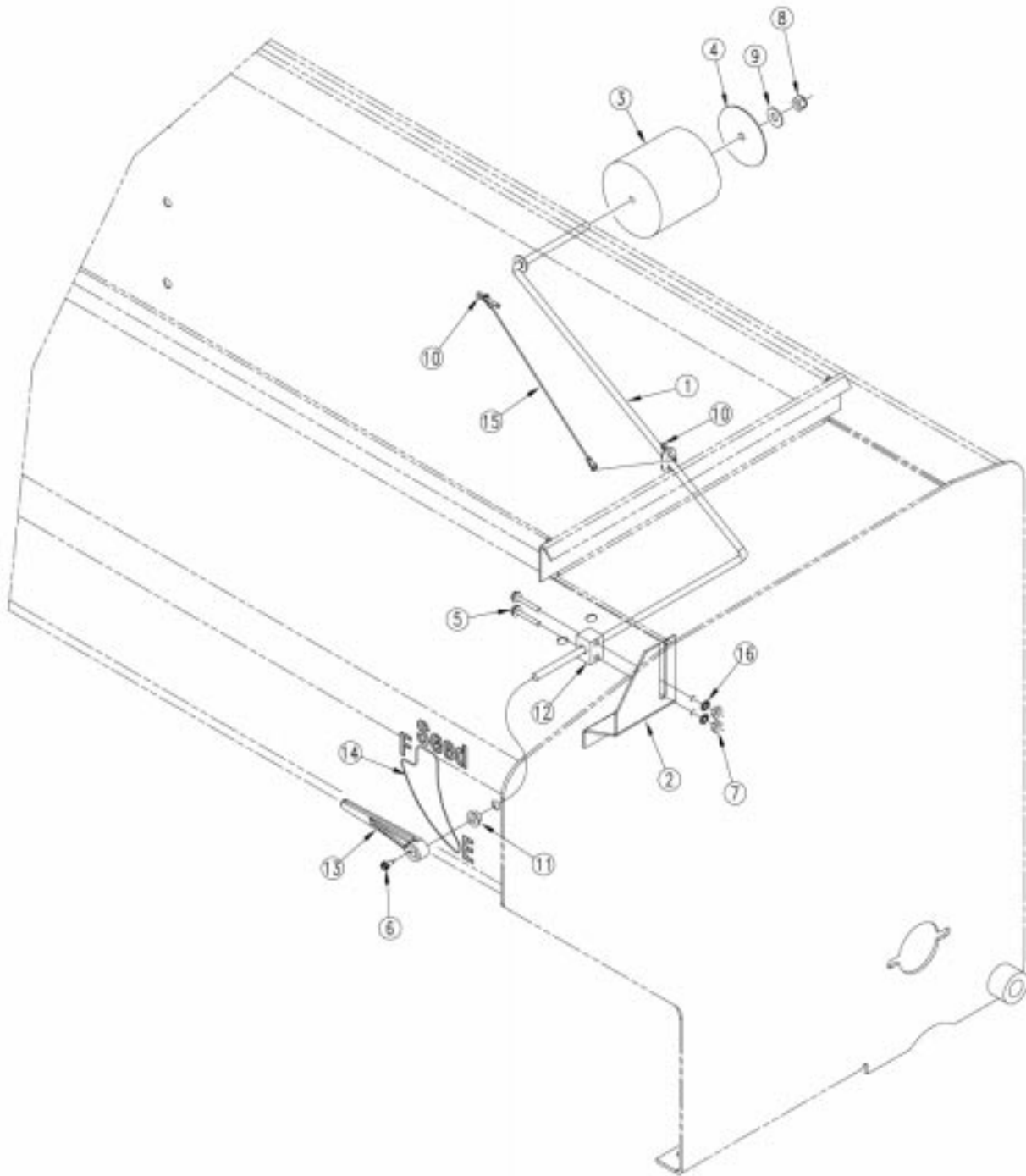

Seed Level Indicator

Ref.	Part No.	Part Description	Comments
1.	118-474H	SEED LEVEL ARM, 6 3/4R. TAB	
2.	118-498D	SEED FLOAT DOWN FLOAT STOP	
3.	197-089D	FOAM FLOAT	
4.	197-096D	FOAM FLOAT WASHER	
5.	801-096C	HFS 10-24 X 1 1/8 PLTD	
6.	801-154C	SCR HEX HD SHT MET #8 X 1/2	
7.	803-001C	NUT HEX 10-24 PLT	
8.	803-255C	NUT HEX NYLOCK 1/4-20	
9.	804-075C	WASHER FLAT 1/4 USS PLT	
10.	805-067C	PIN COTTER 1/8 X 3/4	
11.	817-086C	SEED LEVEL BUSHING	
12.	817-202C	SEED LEVEL ARM MOUNT	
13.	817-350C	SEED LEVEL INDICATOR	
14.	838-237C	DECAL SEED LEVEL LH	
15.	890-305C	CABLE 3/64 X 11 5/8 W/ EYELETS	
16.	804-004C	WASHER INTERNAL STAR #10 PLT	

Legend: ● = 1st revision; ● = 2nd revision; ● = 3rd revision; ● = use up existing stock; ⊗ = not interchangeable; ⊗ ① ● = for example: revision 2 is not interchangeable w/revision 1

Walkboard And Ladder (SN 10337C-)

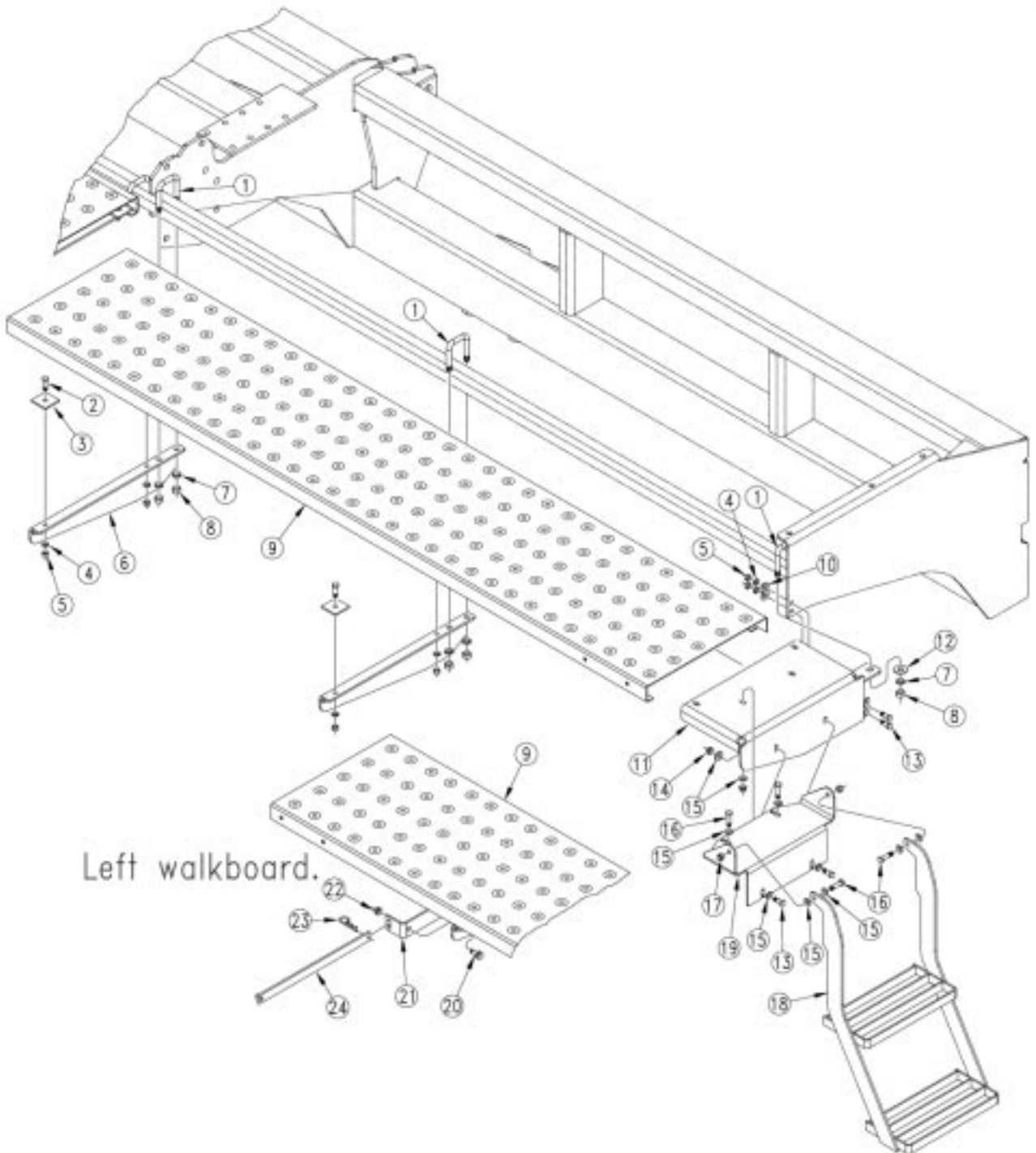

Walkboard And Ladder (SN 10337C-)

Ref.	Part No.	Part Description	Comments
1.	806-005C	U-BOLT 1/2-13 X 2 X 3 GR 5	
2.	802-079C	HHCS 3/8-16X1 1/4 GR5	
3.	119-032D	3-PT STEP RETAINER	
4.	804-013C	WASHER LOCK SPRING 3/8 PLT	
5.	803-014C	NUT HEX 3/8-16 PLT	
6.	119-225D	WALKBOARD SUPPORT BRACKET	
7.	804-015C	WASHER LOCK SPRING 1/2 PLT	
8.	803-020C	NUT HEX 1/2-13 PLT	
9.	119-155D	WALKBOARD 3 PT 15'	
10.	804-011C	WASHER FLAT 3/8 USS PLT	
11.	119-265H	BM WALKBOARD END BRACKET RH	Shown.
	119-266H	BM WALKBOARD END BRACKET LH	
12.	804-017C	WASHER FLAT 1/2 USS PLT	
13.	802-017C	HHCS 3/8-16X1 GR5	
14.	803-209C	NUT FLANGE LOCK 3/8-16 PLT	
15.	804-012C	WASHER FLAT 3/8 SAE PLT	
16.	802-022C	HHCS 3/8-16X1 1/2 GR5	
17.	803-078C	NUT LOCK 3/8-16 NYLON INSERT	
18.	173-109H	3PT BM LADDER WELDMENT	
19.	173-107D	3PT BM LADDER MOUNT BRACKET	
20.	802-388C	HFS 3/8-16X1 GR5	
21.	119-211D	OPENER HANDLE HOLDER	
22.	803-209C	NUT FLANGE LOCK 3/8-16 PLT	
23.	805-032C	PIN HAIR COTTER .148 WIRE	
24.	198-810H	SPRING ADJ HANDLE WELDMENT	

Legend: ● = 1st revision; ● = 2nd revision; ● = 3rd revision; ● = use up existing stock; ⊗ = not interchangeable; ⊗ ① ● = for example: revision 2 is not interchangeable w/revision 1

Walkboard And Ladder (SN 10338C-10513C)

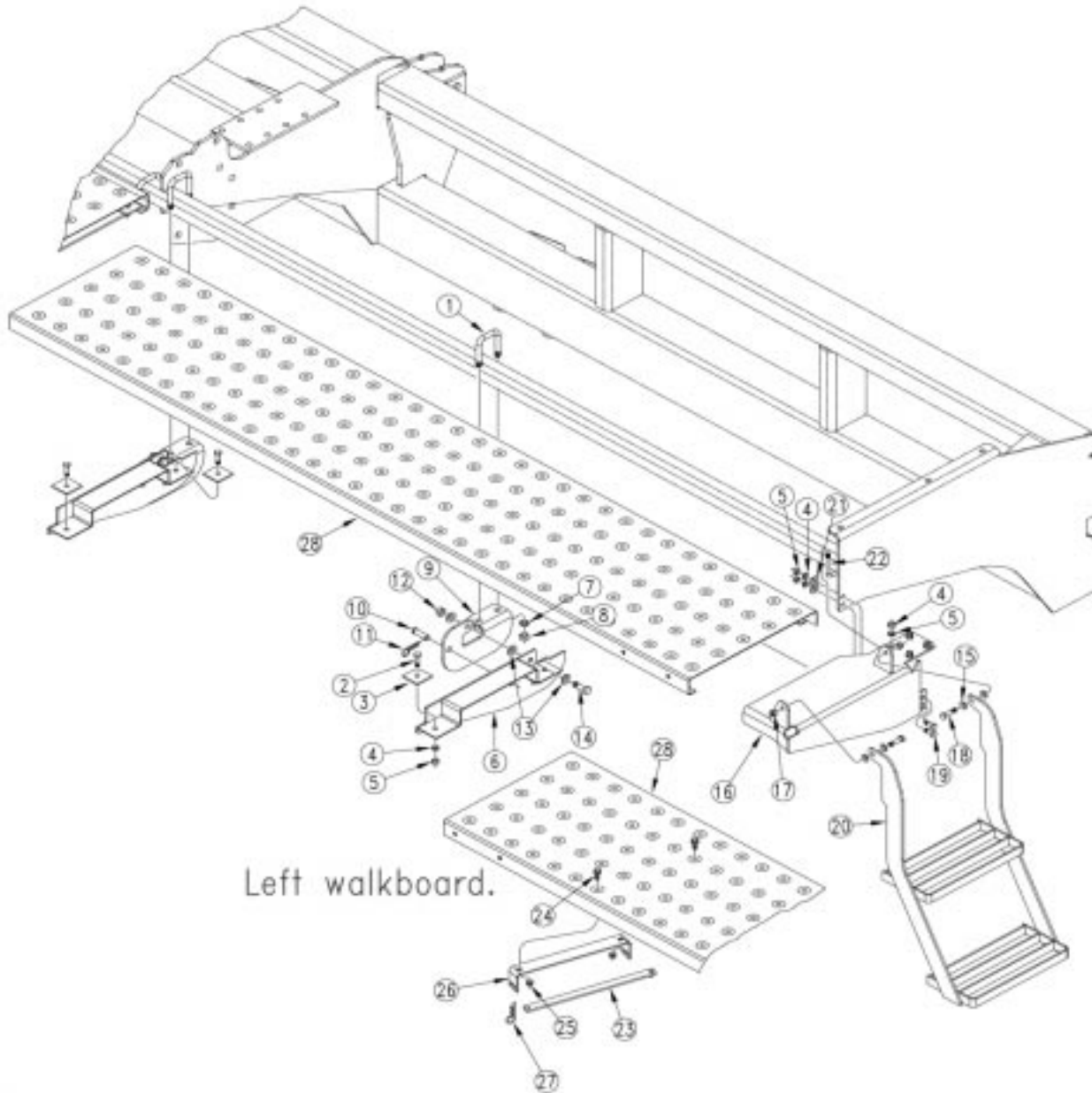

Walkboard And Ladder (SN 10338C-10513C)

Ref.	Part No.	Part Description	Comments
1.	806-005C	U-BOLT 1/2-13 X 2 X 3 GR 5	
2.	802-079C	HHCS 3/8-16X1 1/4 GR5	
3.	119-032D	3-PT STEP RETAINER	
4.	804-013C	WASHER LOCK SPRING 3/8 PLT	
5.	803-014C	NUT HEX 3/8-16 PLT	
6.	119-277H	WALKBOARD HINGE WELDMENT	
7.	804-015C	WASHER LOCK SPRING 1/2 PLT	
8.	803-020C	NUT HEX 1/2-13 PLT	
9.	119-254D	WALKBOARD PIVOT BASE	
10.	805-127C	PIN CLEVIS 1/2 X 1 3/4	
11.	805-143C	PIN HAIR COTTER .120 PLT	
12.	803-019C	NUT LOCK 1/2-13 PLT	
13.	804-016C	WASHER FLAT 1/2 SAE PLT	
14.	802-091C	HHCS 1/2-13X1 1/2 GR5	
15.	804-012C	WASHER FLAT 3/8 SAE PLT	
16.	119-280H	WALKBOARD HINGED END MOUNT RH	
	119-279H	WALKBOARD HINGED END MOUNT LH	
17.	803-078C	NUT LOCK 3/8-16 NYLON INSERT	
18.	802-022C	HHCS 3/8-16X1 1/2 GR5	
19.	802-017C	HHCS 3/8-16X1 GR5	
20.	173-109H	3PT BM LADDER WELDMENT	
21.	804-011C	WASHER FLAT 3/8 USS PLT	
22.	803-004C	NUT HEX SS 1/4-20	
23.	198-810H	SPRING ADJ HANDLE WELDMENT	
24.	802-017C	HHCS 3/8-16X1 GR5	
25.	803-013C	NUT LOCK 3/8-16 PLT	
26.	119-211D	OPENER HANDLE HOLDER	
27.	805-032C	PIN HAIR COTTER .148 WIRE	
28.	119-260D	WALKBOARD 17.25 X 86.0	

Legend: ● = 1st revision; ● = 2nd revision; ● = 3rd revision; ● = use up existing stock; ⊗ = not interchangeable; ⊗ ① ● = for example: revision 2 is not interchangeable w/revision 1

Walkboard And Ladder (S/N 10542C+)

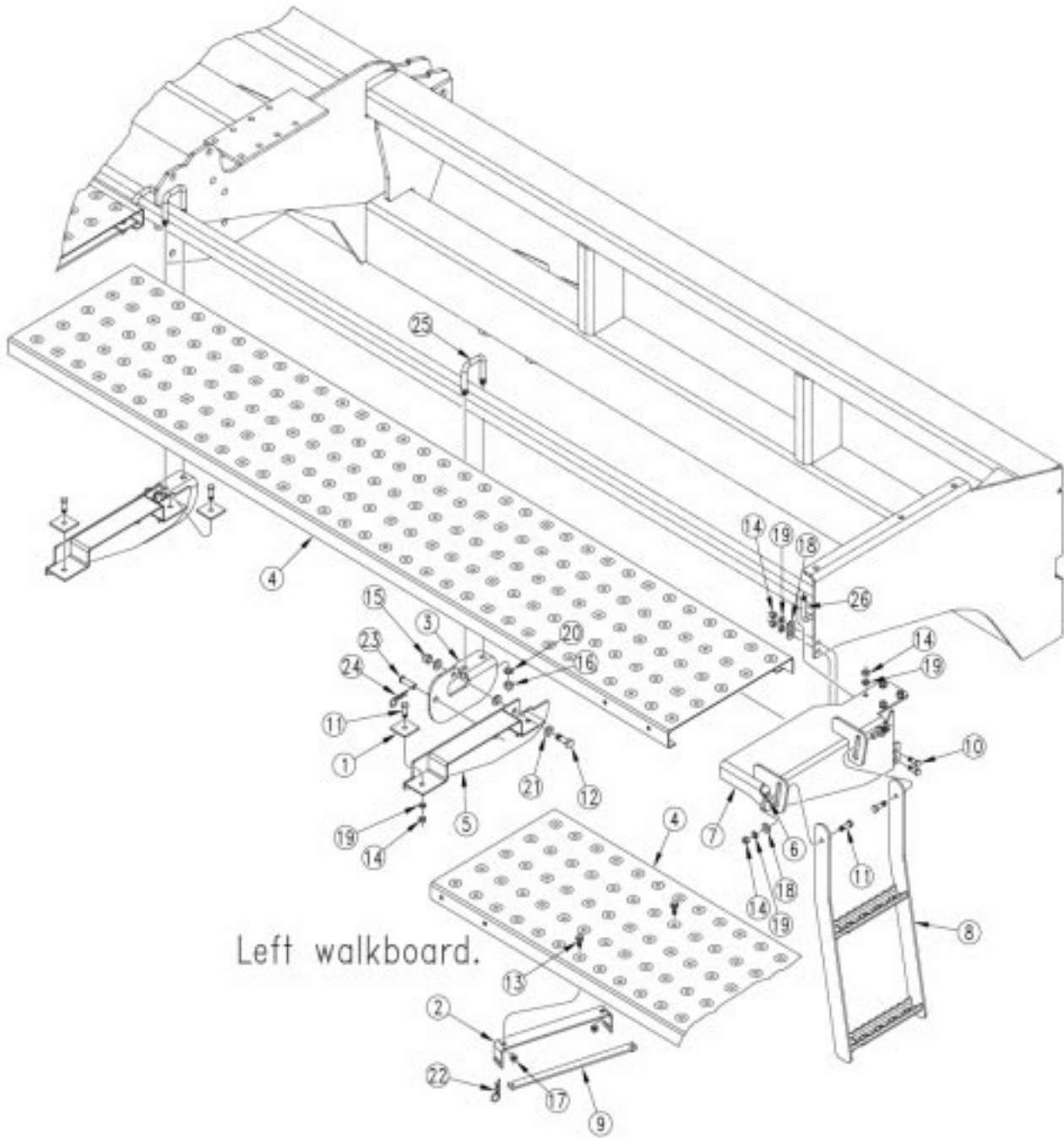

Walkboard And Ladder (S/N 10542C+)

Ref.	Part No.	Part Description	Comments
1.	119-032D	3-PT STEP RETAINER	
2.	119-211D	OPENER HANDLE HOLDER	
3.	119-254D	WALKBOARD PIVOT BASE	
4.	119-260D	WALKBOARD 17.25 X 86.0	
5.	119-277H	WALKBOARD HINGE WELDMENT	
6.	119-278D	WALKBOARD LADDER PIVOT BUSHING	
7.	119-292H	WALKBOARD HINGED END MOUNT LH	
	119-293H	WALKBOARD HINGED END MOUNT RH	Shown
8.	119-294H	3PT HINGED WALKBOARD LADDER	
9.	198-810H	SPRING ADJ HANDLE WELDMENT	
10.	802-017C	HHCS 3/8-16X1 GR5	
11.	802-079C	HHCS 3/8-16X1 1/4 GR5	
12.	802-091C	HHCS 1/2-13X1 1/2 GR5	
13.	802-388C	HFS 3/8-16X1 GR5	
14.	803-014C	NUT HEX 3/8-16 PLT	
15.	803-019C	NUT LOCK 1/2-13 PLT	
16.	803-020C	NUT HEX 1/2-13 PLT	
17.	803-209C	NUT FLANGE LOCK 3/8-16 PLT	
18.	804-011C	WASHER FLAT 3/8 USS PLT	
19.	804-013C	WASHER LOCK SPRING 3/8 PLT	
20.	804-015C	WASHER LOCK SPRING 1/2 PLT	
21.	804-016C	WASHER FLAT 1/2 SAE PLT	
22.	805-032C	PIN HAIR COTTER .148 WIRE	
23.	805-127C	PIN CLEVIS 1/2 X 1 3/4	
24.	805-143C	PIN HAIR COTTER .120 PLT	
25.	806-005C	U-BOLT 1/2-13 X 2 X 3 GR 5	
26.	806-166C	U-BOLT 3/8-16 X 2 1/32 X 3	

Legend: ● = 1st revision; ● = 2nd revision; ● = 3rd revision; ● = use up existing stock; ⊗ = not interchangeable; ⊗ ① ● = for example: revision 2 is not interchangeable w/revision 1

Singulating Meter

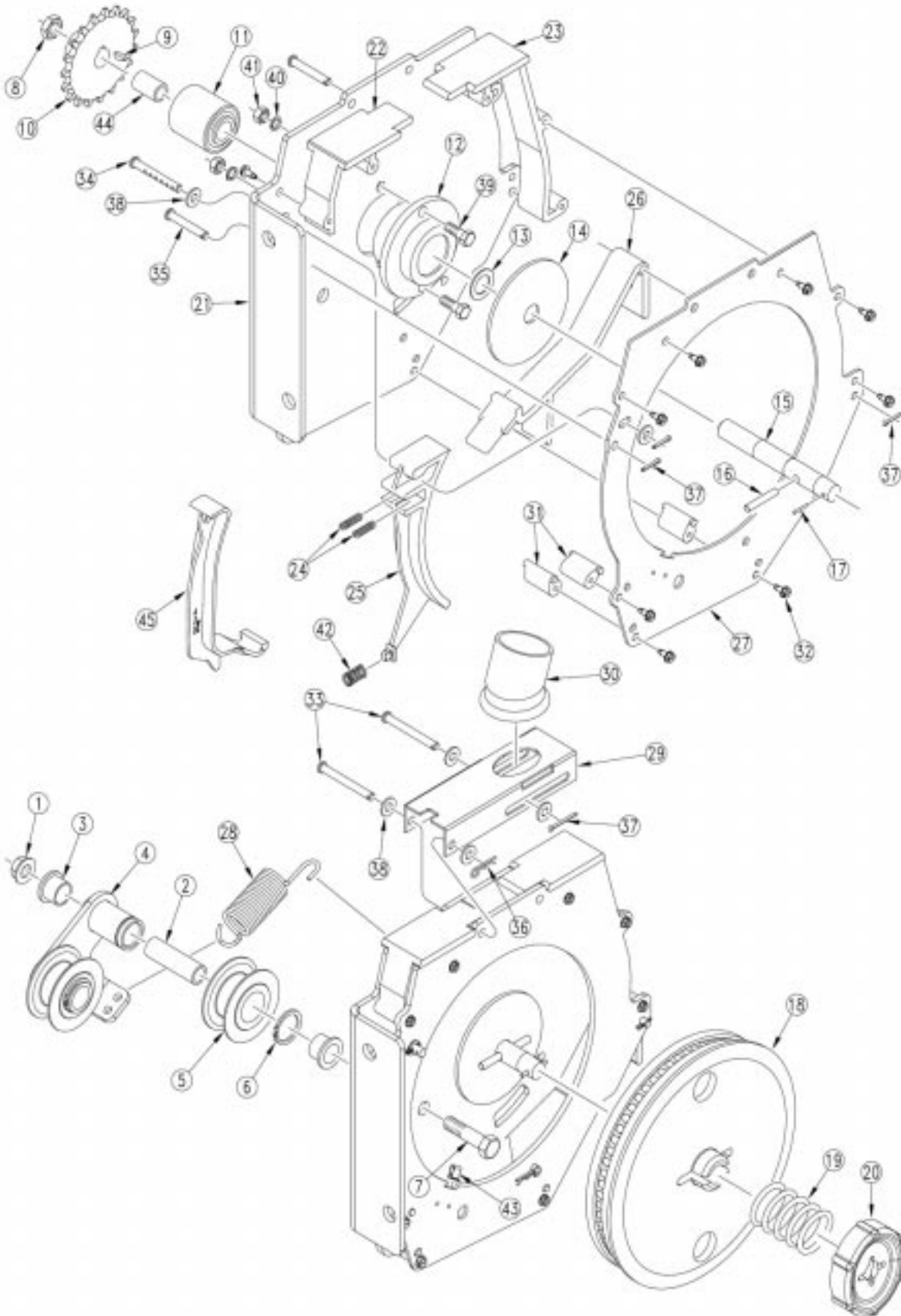

Singulating Meter

3

Ref.	Part No.	Part Description	Comments
1.	803-229C	NUT HEX FLANGE LOC 7/16-14 PLT	
2.	402-282D	PSS IDLER INNER PIVOT TUBE	
3.	817-083C	PRESS WHEEL ARM PIVOT BUSHING	
4.	402-149H	PSS METER IDLER BRACKET WLDMT	
5.	817-406C	IDLER 1 PC 2.38X1.01X1.062	
6.	800-085C	SNAP RING EXT 1 HEAVY	
7.	802-315C	HHCS 7/16-14X2 3/4 GR5	
8.	803-302C	NUT HEX JAM NYLOCK 5/8-18 PLT	
9.	800-046C	WOODRUFF KEY #606	
10.	808-277C	SPKT 41B19 X 5/8 BORE W/KYWAY	
11.	822-170C	BEARING PRESS WHEEL ASSEMBLY	
12.	403-056D	PSS METER HUB	
13.	804-111C	WASHER MACH 1.00 X .625 X 14GA	
14.	403-058D	PSS METER WHEEL SUPPORT PLATE	
15.	403-057D	PSS METER SHAFT SHORT	
16.	805-146C	PIN ROLL 1/4 X 2 LG PL	
17.	805-080C	PIN ROLL 1/8 X 1LG. PLT.	
18.	403-061D	PSS SOYBEAN WHEEL 2700-3200	
	403-066D	PSS SOYBEAN WHEEL 3100-3800	
	403-068D	PSS SOYBEAN WHEEL 3600-4000	
	403-070D	PSS SOYBEAN WHEEL 2200-2700	
	403-071D	PSS SOYBEAN WHEEL 1700-2200	
	403-142D	PSS MED RATE RICE-RIBBON	
	403-095D	PSS HIGH RATE RICE-RIBBON	Use with part # 45 only
	② 403-092D	PSS MILO WHEEL 51 POCKETS 10500-18000	
	① 403-079D	MILO WHEEL OB REPL BY 403-092D	
	② 403-093D	PSS MILO WHEEL 102 POCKETS 10500-18000	
	① 403-080D	MILO WHEEL OB REPL BY 403-093D	
	403-081D	PSS MILO WHEEL 135 POCKETS 12000-18000	
	403-082D	PSS MILO WHEEL 270 POCKETS 12000-18000	
	403-090D	PSS MILO WHEEL 135 POCKETS 10500-14000	
	403-091D	PSS MILO WHEEL 270 POCKETS 10500-14000	
	403-085D	PSS WHEAT WHEEL-HIGH RATE	
	403-060D	PSS WHEAT WHEEL	
	403-094D	PSS VOLUMETRIC #3	
	403-076D	PSS COTTON WHEEL 5200-6000	
	403-077D	PSS COTTON WHEEL 4600-5200	
	403-078D	PSS COTTON WHEEL 4000-4600	
	403-083D	PSS CORN RNDS 1400-1900 28CELL	
	403-096D	PSS CORN RNDS 1700-2200 28CELL	
	403-098D	PSS CORN RNDS 1700-2000 42CELL	
	403-097D	PSS CORN RNDS 1400-1700 42CELL	
	403-086D	PSS CORN FLAT 1500-1675 28CELL	
	403-088D	PSS CORN FLAT 1625-1800 28CELL	
	807-187C	SPRING COMP 1.46ODX1.5X.112W	
19.		KNOB	
20.	② 817-425C	SPRING RETAINER, FORMED	Replaced by 817-425C.
	① 403-052D	PSS METER MOUNT PLATE FORMED	
21.	403-053D	METER FRONT CAP	
22.	817-403C	METER REAR CAP	
23.	817-404C	METER REAR CAP	
24.	807-186C	SPRING COMP .39ODX.75LGX.047W	
25.	817-405C	METER SEED CUTOFF SLIDE	
26.	817-402C	METER CLEANOUT DOOR	
27.	403-054D	PSS METER COVER PLATE	
28.	807-185C	SPRING EX 1ODX3.5LX.105 OFFSET	
29.	403-055D	PSS METER TOP CAP FORMED	
30.	816-332C	LOWER SEED TUBE GROMMET	
31.	817-407C	METER SPACER .5X.161X1.062	
32.	801-160C	HWHSTS #10-24X1/2 TYPE F SCREW	
33.	805-182C	PIN CLEVIS 1/4 X 2 7/64 USBL	
34.	805-298C	PIN CLEVIS 1/4 X 2 ADJUSTABLE	
35.	805-296C	PIN CLEVIS 1/4 X 1 31/64 USBL	
36.	805-302C	PIN HAIR COTTER .059W 15/16LG	
37.	805-307C	PIN COTTER 3/32 X 1/2	
38.	804-007C	WASHER FLAT 1/4 SAE PLT	
39.	802-159C	HHCS 5/16-18X1 GR5	
40.	804-009C	WASHER LOCK SPRING 5/16 PLT	
41.	803-008C	NUT HEX 5/16-18 PLT	
42.	807-194C	SPRING COMP .39ODX.69LX.043WSS	
43.	800-319C	CLIP, U-TYPE .156 PANEL X .63W	
44.	403-064D	BM METER SHAFT SPACER	
45.	817-529C	FLOW GATE	Use with Wheel 403-095D only

Legend: ① = 1st revision; ② = 2nd revision; ③ = 3rd revision; ● = use up existing stock; ⊗ = not interchangeable; ⊗ ① ② = for example: revision 2 is not interchangeable w/revision 1

Seed Tray With Telescoping Tubes

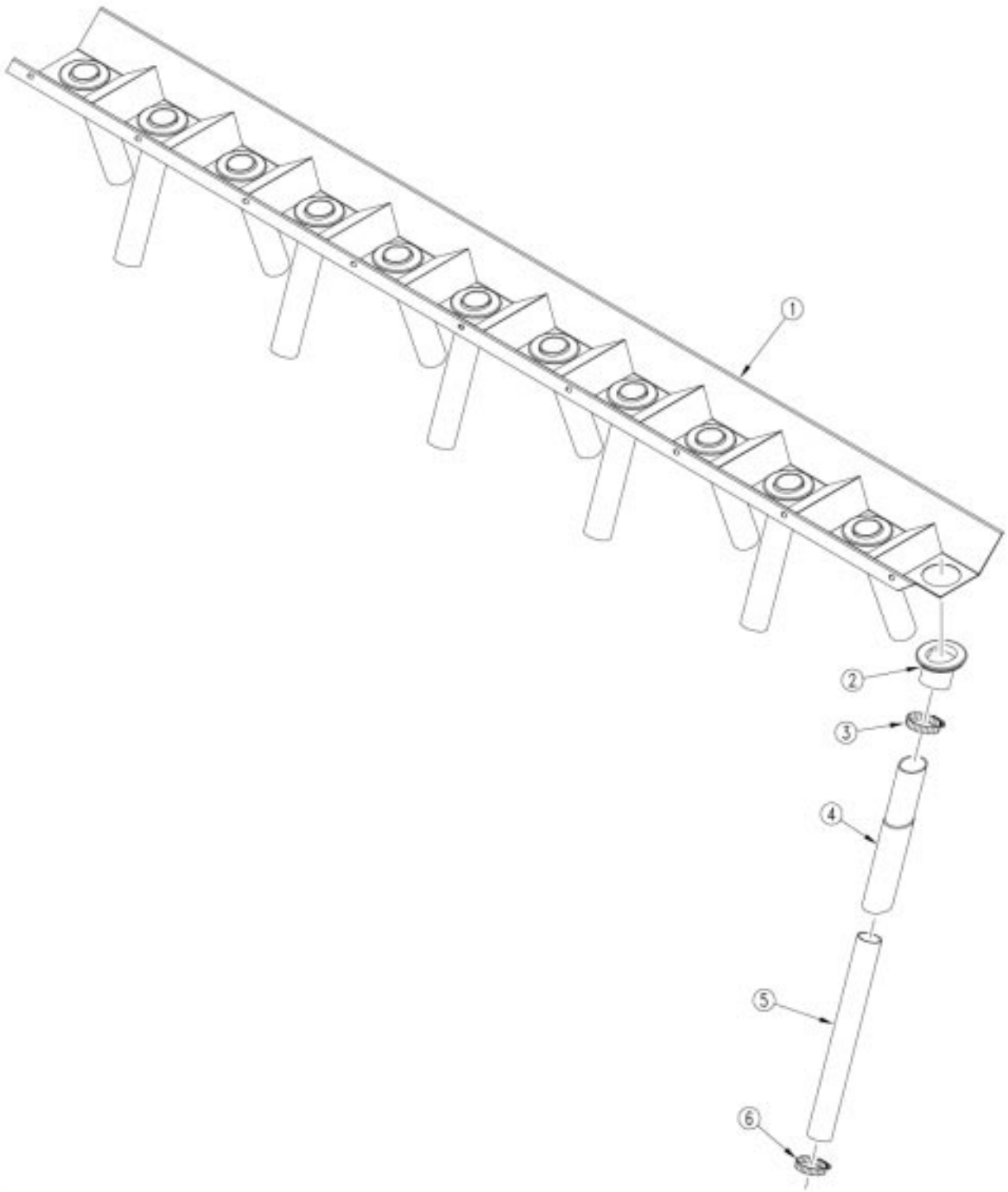

Seed Tray With Telescoping Tubes

Ref.	Part No.	Part Description	Comments
1.	118-726H	SEED TRAY WELDM 15-P X 7 1/2	
	118-727H	SEED TRAY WELDM 15-P X 10	
	118-728H	SEED TRAY WELDM 15-P X 15	
	118-809H	SEED TRAY WELDM 15-P X 7 1/2TR	
2.	816-331C	UPPER SEED TUBE GROMMET	
3.	800-104C	CLAMP WRM DRV #28 (1.31-2.25)	
4.	118-539D	PSS OUTER SLIDING SEED TUBE	
5.	817-400C	PSS INNER SLIDING SEED TUBE	
6.	800-311C	CLAMP WRM DRV #24 (1.06-2)	



Legend: ● = 1st revision; ● = 2nd revision; ● = 3rd revision; ● = use up existing stock; ⊗ = not interchangeable; ⊗ ① ● = for example: revision 2 is not interchangeable w/revision 1

Single Gauge Wheel (S/N 10696C -)

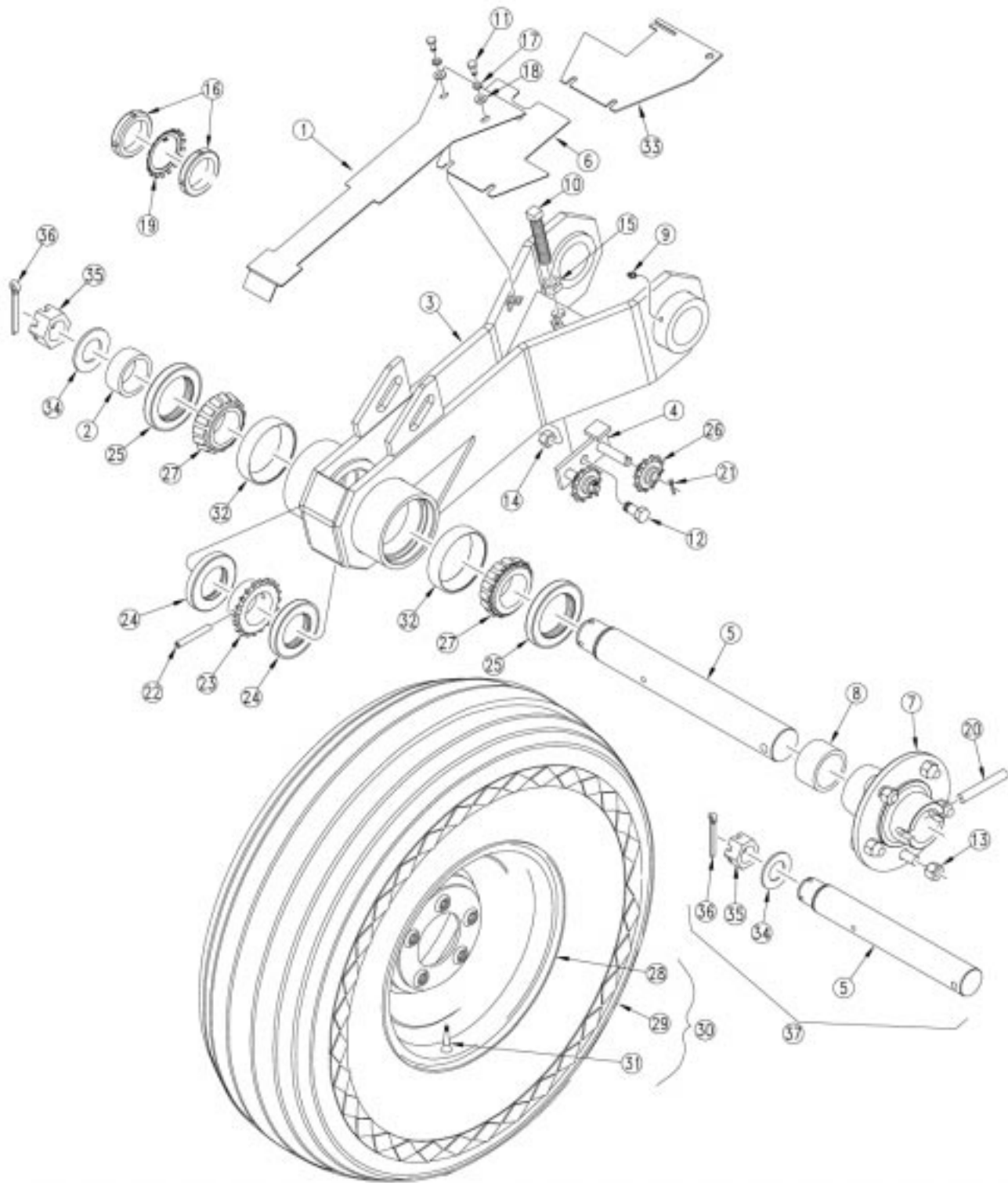

Single Gauge Wheel (S/N 10696C -)

4

Ref.	Part No.	Part Description	Comments
1.	120-197D	GAUGE WHEEL ARM CHAIN GUARD	
2.	120-198D	AXLE SPACER TUBE	
3.	120-208H	GAUGE WHEEL ARM	
4.	120-212H	TWO PIN IDLER WELDMENT	
5.	⊕ 120-321D Ⓜ 120-224D	SPNDL 2 X 15 W/ 1.5-12 THD REP BY 120-314A	Includes items 5,34,35,36
6.	120-230D	G.W. ARM EXTENDED CHAIN GUARD	RH Gauge Wheel
7.	120-237S	HUB 5 BOLT SUB ASSEMBLY	
8.	120-242D	AXLE SPACER TUBE;LONG	
9.	800-001C	GREASE ZERK STRAIGHT 1/4-28	
10.	801-059C	SCREW SQ HD 5/8-11X3 1/2 GR5	
11.	802-078C	HHCS 1/4-20X5/8 GR5	
12.	802-258C	HHCS 1/2-13X1 GR5	
13.	803-017C	NUT LUG 1/2-20X90DEG PLT 13/16	
14.	803-019C	NUT LOCK 1/2-13 PLT	
15.	803-023C	NUT HEX JAM 5/8-11 PLT	
16.	803-208C	NUT BEARING LOCK, TN-10	S/N 10513C-
17.	804-006C	WASHER LOCK SPRING 1/4 PLT	
18.	804-007C	WASHER FLAT 1/4 SAE PLT	
19.	804-098C	WASHER BEARING LOCK, TW110	S/N 10513C-
20.	805-098C	PIN SPIROL 1/2 X 2 3/4	
21.	805-067C	PIN COTTER 1/8 X 3/4	
22.	805-125C	PIN ROLL 5/16 X 2 1/2 PLT	
23.	808-275C	SPKT 40B27X2B W/5/16 HOLE	
24.	816-012C	SEAL 3.375 X 2.0 X.438 CR20125	
25.	816-138C	SEAL DBL LIP 2.5 ID X 3.881 OD	
26.	817-025C	NO. 40 12T IDLER SPKT.	
27.	822-117C	BEARING CONE 2 TIM33889	
28.	814-005C	WHEEL 6 X 15 X 5 BOLT	
29.	814-026C	TIRE 9.5L X 15 6 PLY RIB IMP	
30.	109-058K	TIRE 9.5LX15 ON 6IN 5BOLT RIM	Includes 28,29 & 31
31.	816-035C	VALVE STEM TR415X.625X1 1/4 LG	
32.	822-118C	BEARING CUP 2 TIM33821	
33.	120-312D	GW EXTENDED CHAIN GUARD,SENSOR	LH Gauge Wheel
34.	804-182C	WASHER HARD 1 1/2 MILCARB GR8	S/N 10514C+
35.	803-239C	NUT HEX SLOTTED 1 1/2-12	S/N 10514C+
36.	805-148C	PIN COTTER 3/8 X 3 PLT	S/N 10514C+
37.	120-314A	SPINDLE KIT	

Legend: Ⓜ = 1st revision; ⊕ = 2nd revision; ⊕ = 3rd revision; ● = use up existing stock; ⊗ = not interchangeable; ⊗ ⊕ ⊕ = for example: revision 2 is not interchangeable w/revision 1

Single Gauge Wheel (S/N 10697C+)

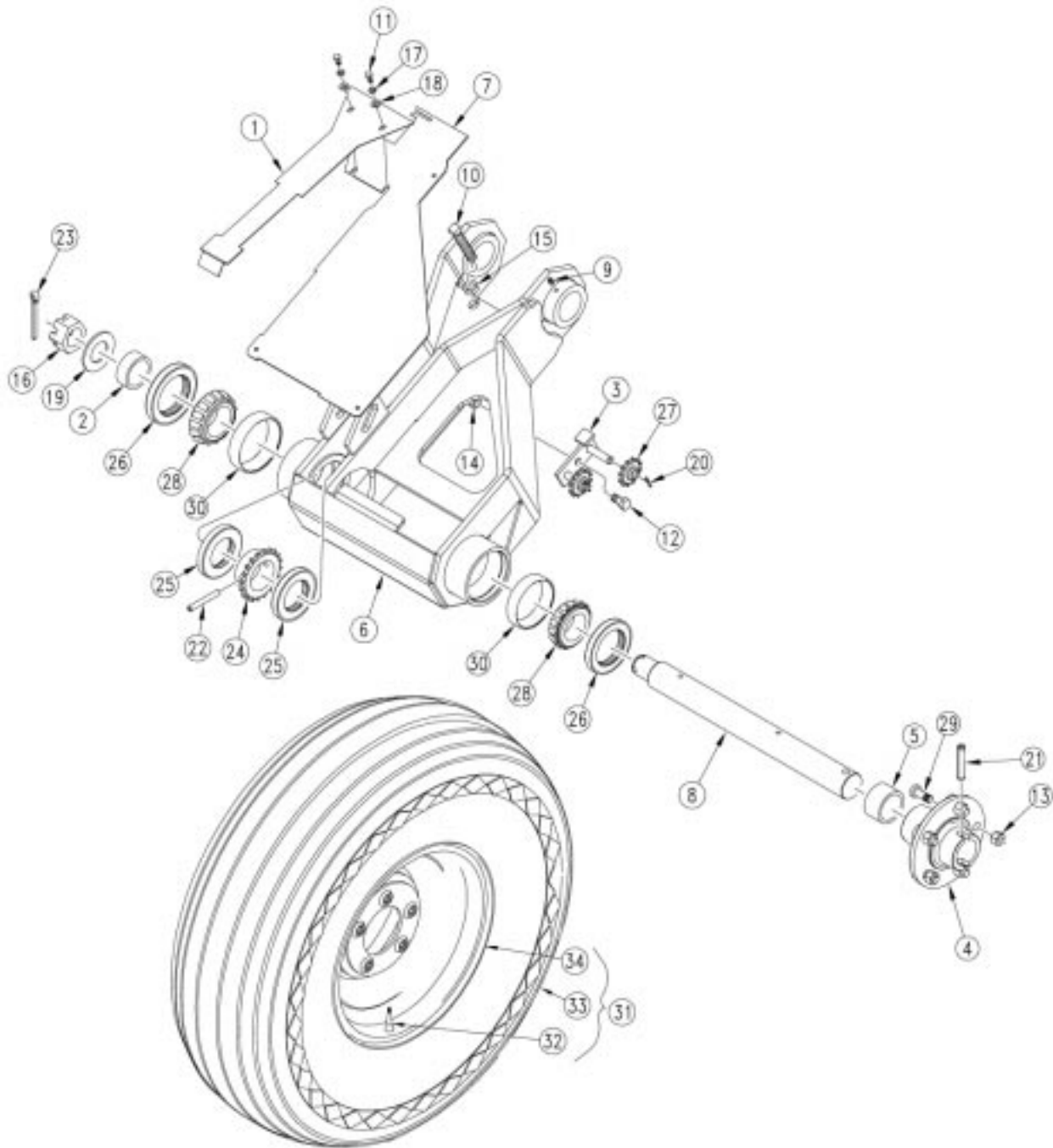

Single Gauge Wheel (S/N 10697C+)

Ref.	Part No.	Part Description	Comments
1.	120-197D	GAUGE WHEEL ARM CHAIN GUARD	
2.	120-198D	AXLE SPACER TUBE	
3.	120-212H	TWO PIN IDLER WELDMENT	
4.	120-253D	HUB 5-BOLT 2 DIA BORE	
5.	120-242D	AXLE SPACER TUBE;LONG	
6.	120-302H	GAUGE WHEEL ARM 3PT-P LH OFFST	
7.	120-326D	GAUGE WHEEL OFFSET CHAIN GAURD	
8.	120-327D	SPNDL 2 X 26.56 W/ 1.5-12 THD	
9.	800-001C	GREASE ZERK STRAIGHT 1/4-28	
10.	801-059C	SCREW SQ HD 5/8-11X3 1/2 GR5	
11.	802-078C	HHCS 1/4-20X5/8 GR5	
12.	802-258C	HHCS 1/2-13X1 GR5	
13.	803-017C	NUT LUG 1/2-20X90DEG PLT 13/16	
14.	803-019C	NUT LOCK 1/2-13 PLT	
15.	803-023C	NUT HEX JAM 5/8-11 PLT	
16.	803-239C	NUT HEX SLOTTED 1 1/2-12	
17.	804-006C	WASHER LOCK SPRING 1/4 PLT	
18.	804-007C	WASHER FLAT 1/4 SAE PLT	
19.	804-182C	WASHER HARD 1 1/2 MILCARB GR8	
20.	805-067C	PIN COTTER 1/8 X 3/4	
21.	805-098C	PIN SPIROL 1/2 X 2 3/4	
22.	805-125C	PIN ROLL 5/16 X 2 1/2 PLT	
23.	805-148C	PIN COTTER 3/8 X 3 PLT	
24.	808-275C	SPKT 40B27X2B W/5/16 HOLE	
25.	816-012C	SEAL 3.375 X 2.0 X.438 CR20125	
26.	816-138C	SEAL DBL LIP 2.5 ID X 3.881 OD	
27.	817-025C	NO. 40 12T IDLER SPKT.	
28.	822-117C	BEARING CONE 2 TIM33889	
29.	802-135C	HUB STUD 1/2-20X1 5/8 GR5	
30.	822-118C	BEARING CUP 2 TIM33821	
31.	109-058K	TIRE 9.5LX15 ON 6IN 5BOLT RIM	
32.	816-035C	VALVE STEM TR415X.625X1 1/4 LG	
33.	814-026C	TIRE 9.5L X 15 6 PLY RIB IMP	
34.	814-005C	WHEEL 6 X 15 X 5 BOLT	

Legend: ● = 1st revision; ● = 2nd revision; ● = 3rd revision; ● = use up existing stock; ⊗ = not interchangeable; ⊗ ⊕ ● = for example: revision 2 is not interchangeable w/revision 1

Dual Gauge Wheel (S/N 10697C+)

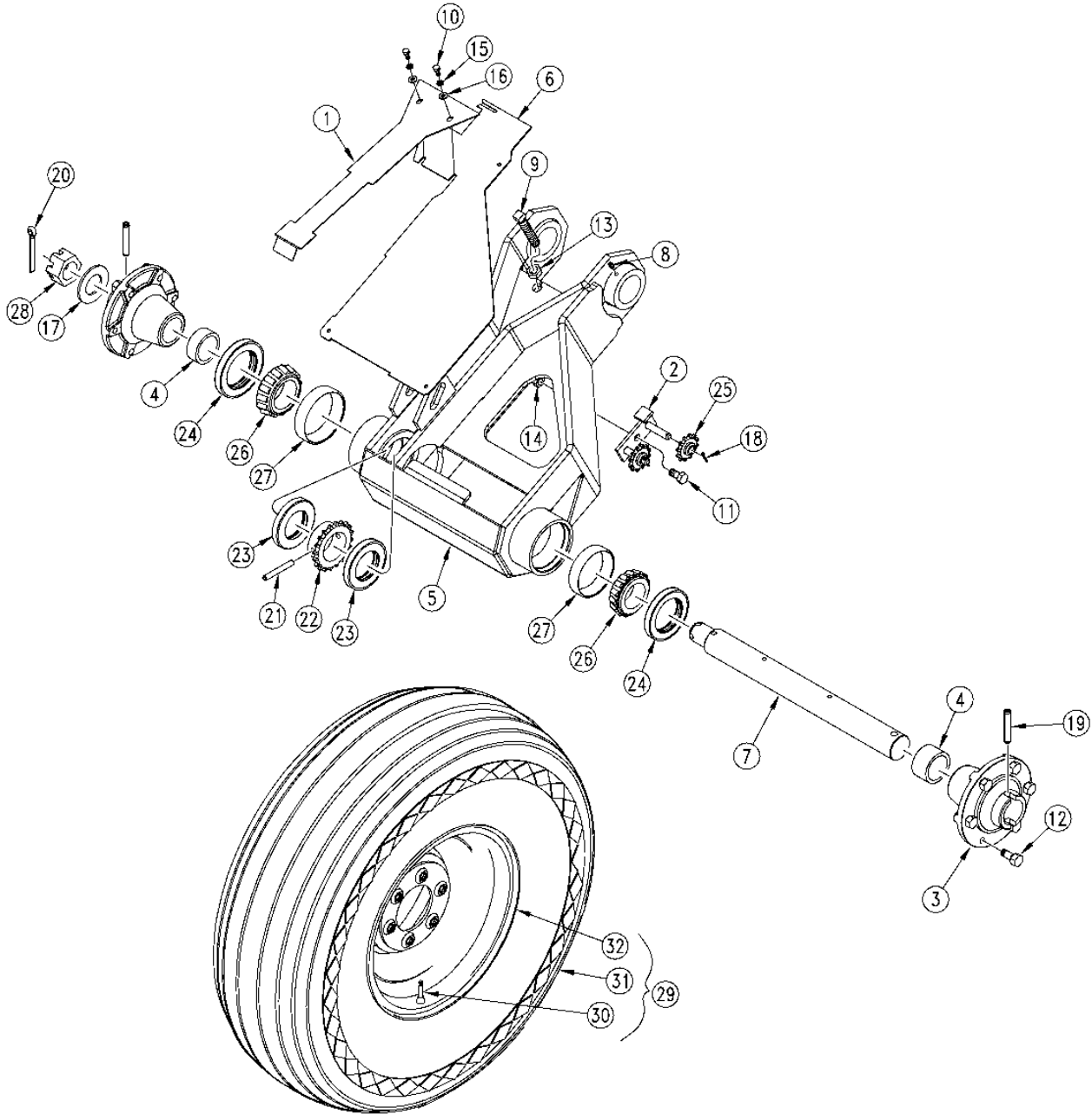

Dual Gauge Wheel (S/N 10697C+)

Ref.	Part No.	Part Description	Comments
1.	120-197D	GAUGE WHEEL ARM CHAIN GUARD	
2.	120-212H	TWO PIN IDLER WELDMENT	
3.	120-253D	HUB 5-BOLT 2 DIA BORE	
4.	120-242D	AXLE SPACER TUBE;LONG	
5.	120-302H	GAUGE WHEEL ARM 3PT-P LH OFFST	
6.	120-326D	GAUGE WHEEL OFFSET CHAIN GAURD	
7.	120-328D	SPNDL 2 X 32.06 W/ 1.5-12 THD	
8.	800-001C	GREASE ZERK STRAIGHT 1/4-28	
9.	801-059C	SCREW SQ HD 5/8-11X3 1/2 GR5	
10.	802-078C	HHCS 1/4-20X5/8 GR5	
11.	802-258C	HHCS 1/2-13X1 GR5	
12.	803-017C	NUT LUG 1/2-20X90DEG PLT 13/16	
13.	803-023C	NUT HEX JAM 5/8-11 PLT	
14.	803-019C	NUT LOCK 1/2-13 PLT	
15.	804-006C	WASHER LOCK SPRING 1/4 PLT	
16.	804-007C	WASHER FLAT 1/4 SAE PLT	
17.	804-182C	WASHER HARD 1 1/2 MILCARB GR8	
18.	805-067C	PIN COTTER 1/8 X 3/4	
19.	805-098C	PIN SPIROL 1/2 X 2 3/4	
20.	805-148C	PIN COTTER 3/8 X 3 PLT	
21.	805-125C	PIN ROLL 5/16 X 2 1/2 PLT	
22.	808-275C	SPKT 40B27X2B W/5/16 HOLE	
23.	816-012C	SEAL 3.375 X 2.0 X.438 CR20125	
24.	816-138C	SEAL DBL LIP 2.5 ID X 3.881 OD	
25.	817-025C	NO. 40 12T IDLER SPKT.	
26.	822-117C	BEARING CONE 2 TIM33889	
27.	802-135C	HUB STUD 1/2-20X1 5/8 GR5	
28.	822-118C	BEARING CUP 2 TIM33821	
29.	803-239C	NUT HEX SLOTTED 1 1/2-12	
30.	109-058K	TIRE 9.5LX15 ON 6IN 5BOLT RIM	
31.	816-035C	VALVE STEM TR415X.625X1 1/4 LG	
32.	814-026C	TIRE 9.5L X 15 6 PLY RIB IMP	
33.	814-005C	WHEEL 6 X 15 X 5 BOLT	

Legend: ● = 1st revision; ● = 2nd revision; ● = 3rd revision; ● = use up existing stock; ⊗ = not interchangeable; ⊗ ① ● = for example: revision 2 is not interchangeable w/revision 1

Gauge Wheel LH

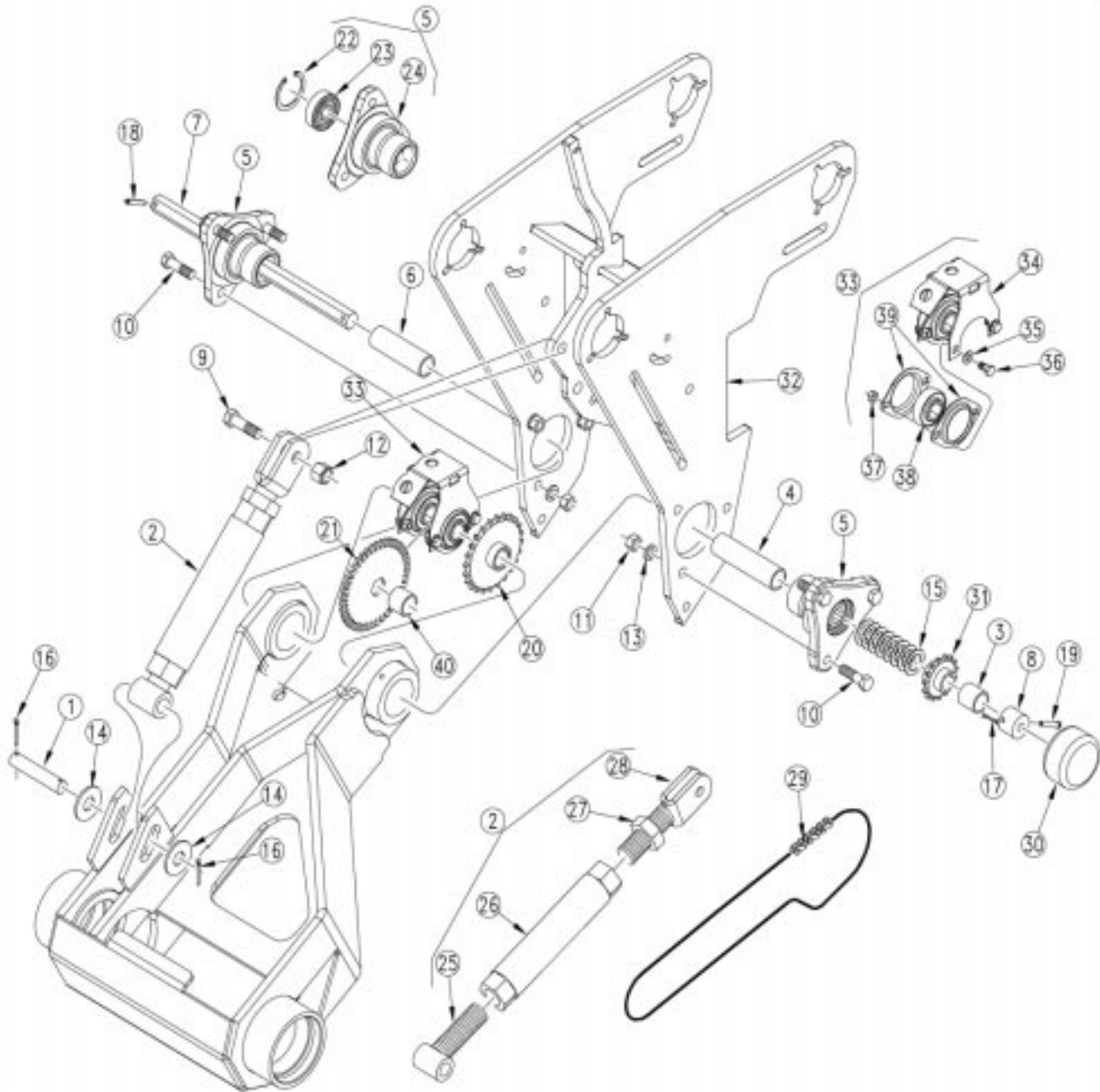

Gauge Wheel LH

Ref.	Part No.	Part Description	Comments
1.	120-229D	PIN,3/4X3 1/4 USE W/3/16 HOLES	
2.	120-245S	3PT GW LINK ASSEMBLY	Includes 25,26,27 & 28
3.	120-315D	SPACER TUBE 1 ID X 1.25	S/N 10513C +
4.	120-265D	SPACER TUBE 1 ID X 4 11/16	
5.	120-269S	3 BOLT PIVOT BEARING ASSY	Includes 22,23 & 24
6.	120-310D	SPACER TUBE 1 ID X 2.25	
7.	120-316D	SHAFT 7/8 HEX GW PIVOT LONG	S/N 10542C +SHOWN
	120-286D	SHAFT 7/8 HEX GW PIVOT	S/N 10513C -
8.	120-287D	ACREMETER HEX SHAFT ADAPTOR	
9.	802-058C	HHCS 5/8-11X2 1/2 GR5	
10.	802-082C	HHCS 1/2-13X1 3/4 GR5	
11.	803-020C	NUT HEX 1/2-13 PLT	
12.	803-148C	NUT HEX NYLOCK 5/8-11 PLT	
13.	804-015C	WASHER LOCK SPRING 1/2 PLT	
14.	804-024C	WASHER FLAT 3/4 USS PLT	
15.	804-061C	WASHER MACH 1.50 X 1.00 X 18GA	
16.	805-045C	PIN COTTER 5/32 X 1 1/4 LG	
17.	805-063C	PIN COTTER 3/32 X 1 LONG	
18.	805-180C	PIN ROLL 1/4 X 1 1/2 LG PLT	
19.	805-296C	PIN CLEVIS 1/4 X 1 31/64 USBL	
20.	808-151C	SPKT 40C24 X 7/8 HEX BORE	
21.	120-309D	SENSOR DISC, 42T 5.3 DIA PLTD	
22.	800-038C	SNAP RING INT 2.05 OD	
23.	188-006V	BEARING .880 HEX BORE 205DD	
24.	120-188D	3 BOLT PIVOT CAST W/BRG SEAT	
25.	120-213H	ADJUSTMENT TUBE EYE BOLT	
26.	120-214H	ADJUSTMENT TUBE WLDMT	
27.	803-046C	NUT HEX JAM 1 1/4-7 LH THD PLT	
28.	120-001E	UPPER GAUGE WHEEL CLEVIS	
29.	136-150D	CHAIN RL #40 108 PITCHES	
30.	890-673C	ACREMETER 15-P 9.5LX15 383 REV	
31.	808-147C	SPKT 40C15 X 7/8 HEX BORE	
	808-276C	SPKT 40C20 X 7/8 HEX BORE	
	808-156C	SPKT 40C30 X 7/8 HEX BORE	
32.	120-276H	GW MOUNT 3PT P DRIVE	
33.	120-291S	SENSOR U-MOUNT BRACKET SUBASSY	Includes 34,35,36,37,38 & 39
34.	120-311D	SENSOR U-MOUNT BRACKET	
35.	804-036C	WASHER FLAT 5/16 SAE PLT	
36.	802-705C	HHCS 5/16-18X5/8	
37.	803-011C	NUT LOCK 5/16-18 PLT	
38.	822-119C	BRG.7/8HEX BR 52MM SPHRICAL OD	
39.	822-032C	FLANGETTE 52 MST	
40.	120-278D	SPACER TUBE 1 ID X 1.03	

Legend: ● = 1st revision; ● = 2nd revision; ● = 3rd revision; ● = use up existing stock; ⊗ = not interchangeable; ⊗ ① ● = for example: revision 2 is not interchangeable w/revision 1

Gauge Wheel RH

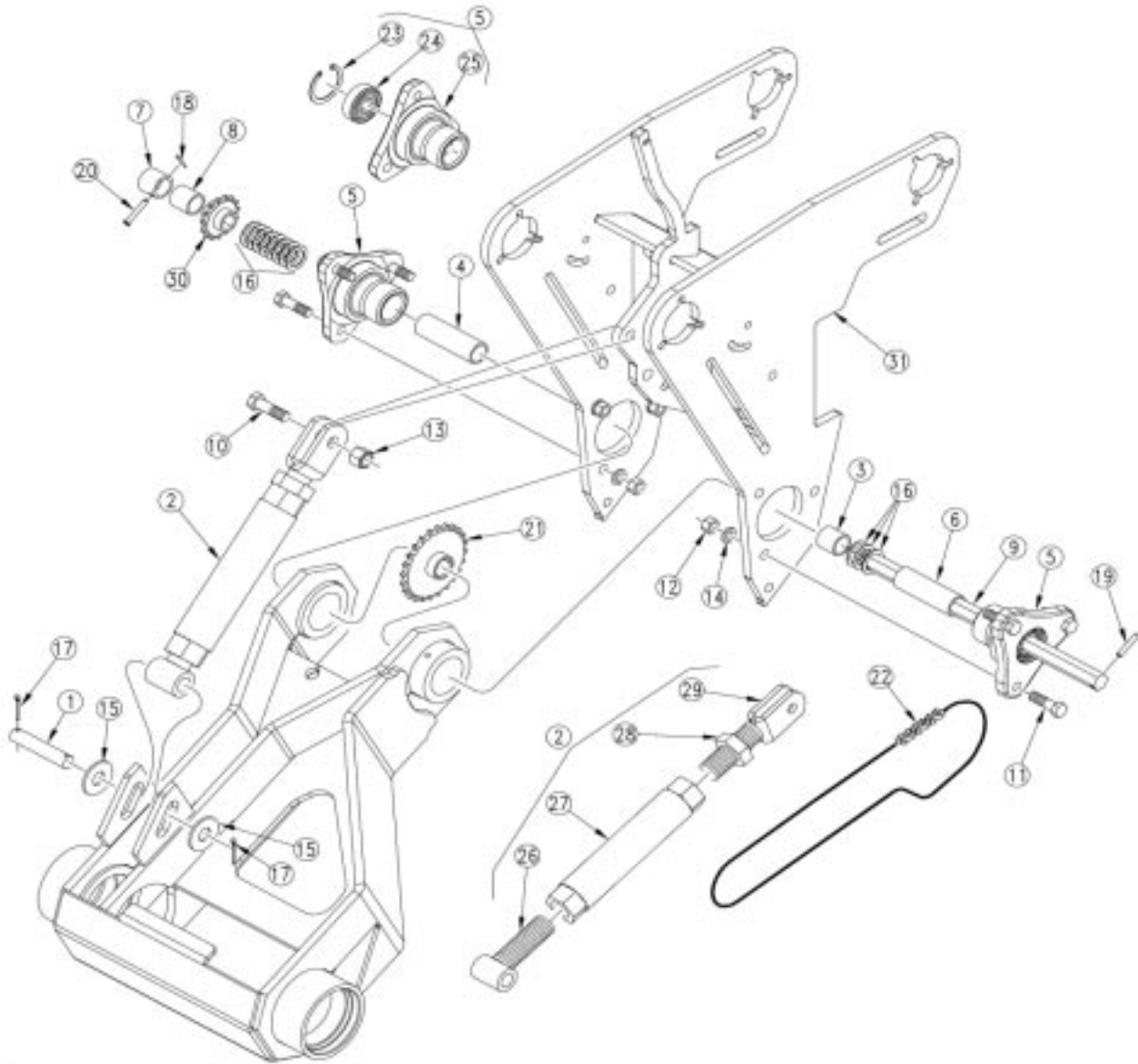

Gauge Wheel RH

Ref.	Part No.	Part Description	Comments
1.	120-229D	PIN,3/4X3 1/4 USE W/3/16 HOLES	
2.	120-245S	3PT GW LINK ASSEMBLY	Includes 26,27,28 & 29
3.	120-264D	SPACER TUBE 1 ID X 1 3/16	
4.	120-265D	SPACER TUBE 1 ID X 4 11/16	
5.	120-269S	3 BOLT PIVOT BEARING ASSY	Includes 23,24 & 25
6.	120-284D	SPACER TUBE 1 ID X 3.94	
7.	120-287D	ACREMETER HEX SHAFT ADAPTOR	
8.	120-315D	SPACER TUBE 1 ID X 1.25	S/N 10542C +
9.	120-316D	SHAFT 7/8 HEX GW PIVOT LONG	S/N 10542C + Shown
	120-286D	SHAFT 7/8 HEX GW PIVOT	S/N 10512C -
10.	802-055C	HHCS 5/8-11X2 GR5	
11.	802-082C	HHCS 1/2-13X1 3/4 GR5	
12.	803-020C	NUT HEX 1/2-13 PLT	
13.	803-148C	NUT HEX NYLOCK 5/8-11 PLT	
14.	804-015C	WASHER LOCK SPRING 1/2 PLT	
15.	804-024C	WASHER FLAT 3/4 USS PLT	
16.	804-061C	WASHER MACH 1.50 X 1.00 X 18GA	
17.	805-045C	PIN COTTER 5/32 X 1 1/4 LG	
18.	805-063C	PIN COTTER 3/32 X 1 LONG	
19.	805-180C	PIN ROLL 1/4 X 1 1/2 LG PLT	
20.	805-296C	PIN CLEVIS 1/4 X 1 31/64 USBL	
21.	808-151C	SPKT 40C24 X 7/8 HEX BORE	
22.	136-150D	CHAIN RL #40 108 PITCHES	
23.	800-038C	SNAP RING INT 2.05 OD	
24.	188-006V	BEARING .880 HEX BORE 205DD	
25.	120-188D	3 BOLT PIVOT CAST W/BRG SEAT	
26.	120-213H	ADJUSTMENT TUBE EYE BOLT	
27.	120-214H	ADJUSTMENT TUBE WLDMT	
28.	803-046C	NUT HEX JAM 1 1/4-7 LH THD PLT	
29.	120-001E	UPPER GAUGE WHEEL CLEVIS	
30.	808-147C	SPKT 40C15 X 7/8 HEX BORE	
	808-276C	SPKT 40C20 X 7/8 HEX BORE	

Legend: ● = 1st revision; ● = 2nd revision; ● = 3rd revision; ● = use up existing stock; ⊗ = not interchangeable; ⊗ ① ● = for example: revision 2 is not interchangeable w/revision 1

Gauge Wheel Transmission (S/N 10513C -)

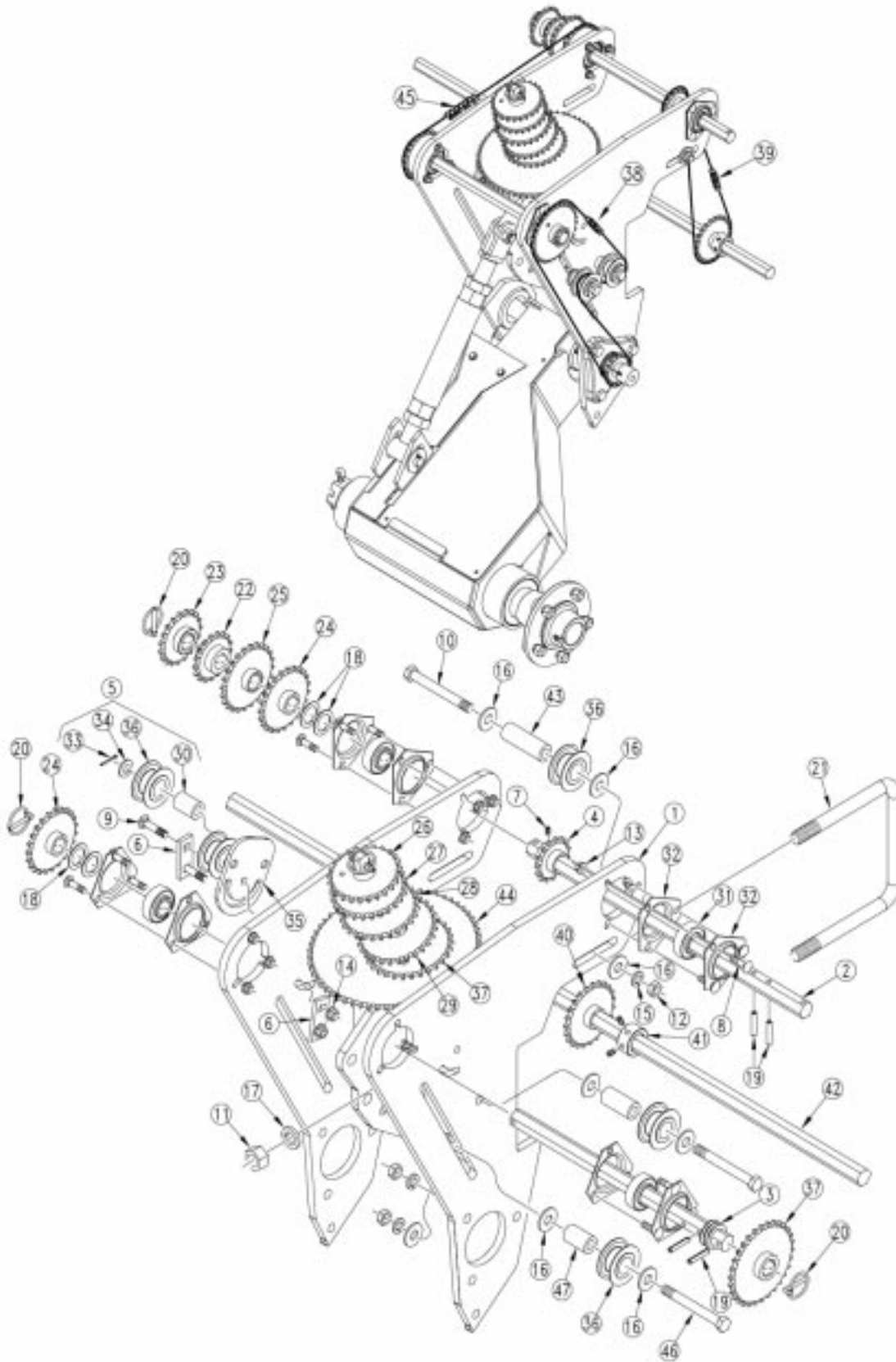

18186

Gauge Wheel Transmission (S/N 10513C -)

Ref.	Part No.	Part Description	Comments
1.	120-276H	GW MOUNT 3PT P DRIVE	
2.	120-285D	SHAFT 7/8 HEX GW UPPER REAR	
3.	120-289D	SHAFT 7/8 HEX GW UPPER FRNT	
4.	120-290D	SPKT 40C15 7/8 HEX W/ SS HOLES	
5.	402-140S	DOUBLE SPOOL IDLER ASSY	
6.	402-242D	IDLER BOLT PLATE	
7.	801-035C	SCREW SET 5/16-18 SKT KP X 3/8	
8.	802-009C	RHSNB 5/16-18X1 1/4 GR5	
9.	802-252C	RHSNB 3/8-16X1 3/4 GR5	
10.	802-672C	HHCS 1/2-13X4 1/2 GR5 SPTH	
11.	803-027C	NUT HEX 3/4-10 PLT	
12.	803-036C	NUT HEX JAM 1/2-13 PLT	
13.	803-177C	NUT HEX LOCK 5/16-18 FLG.	
14.	803-209C	NUT FLANGE LOCK 3/8-16 PLT	
15.	804-015C	WASHER LOCK SPRING 1/2 PLT	
16.	804-113C	WASHER FLAT 1/2 USS HARD PLT	
17.	804-023C	WASHER LOCK SPRING 3/4 PLT	
18.	804-061C	WASHER MACH 1.50 X 1.00 X 18GA	
19.	805-180C	PIN ROLL 1/4 X 1 1/2 LG PLT	
20.	805-240C	PIN LYNCH 3/16 X 1 9/16 LONG	
21.	806-121C	U-BOLT 3/4-10 X 7 1/32 X 7 1/2	
22.	808-148C	SPKT 40C17 X 7/8 HEX BORE	
23.	808-149C	SPKT 40C19 X 7/8 HEX BORE	
24.	808-150C	SPKT 40C23 X 7/8 HEX BORE	
25.	808-151C	SPKT 40C24 X 7/8 HEX BORE	
26.	808-152C	SPKT 40C25 X 7/8 HEX BORE	
27.	808-153C	SPKT 40C26 X 7/8 HEX BORE	
28.	808-154C	SPKT 40C27 X 7/8 HEX BORE	
29.	808-155C	SPKT 40C28 X 7/8 HEX BORE	
30.	120-305D	TUBE RND 1 OD X 7/32W X 1.56	
31.	822-119C	BRG.7/8HEX BR 52MM SPHRICAL OD	
32.	822-175C	FLANGETTE 52 3-BOLT PLT	
33.	805-064C	PIN COTTER 7/64 X 1 LONG	
34.	804-016C	WASHER FLAT 1/2 SAE PLT	
35.	402-126H	OFFSET DOUBLE IDLER WELDMNT	
36.	817-406C	IDLER 1 PC 2.38X1.01X1.062	
37.	808-156C	SPKT 40C30 X 7/8 HEX BORE	
38.	136-174D	CHAIN RL #40 118 PITCHES	
39.	136-035D	CHAIN RL #40 76 PITCHES	
40.	808-155C	SPKT 40C28 X 7/8 HEX BORE	
41.	402-025S	LOCK COLLAR, 7/8 HEX W/ SET SC	
42.	120-291D	SHAFT 7/8 HEX 88.0 LONG PLTD	
	*120-307D	76" LONG SHAFT (TWIN ROW) ONLY	
43.	120-293D	TUBE RND DOM. 1 OD X 7/32WX3.0	
44.	195-172H	SPKT 40C60 X 7/8 HEX BORE	
45.	136-058D	CHAIN RL #40 102 PITCHES	
46.	802-424C	HHCS 1/2-13X4 FTHD	
47.	120-306D	TUBE RND 1 OD X 7/32W X 2.13	

Legend: ● = 1st revision; ● = 2nd revision; ● = 3rd revision; ● = use up existing stock; ⊗ = not interchangeable; ⊗ ① ● = for example: revision 2 is not interchangeable w/revision 1

Gauge Wheel Transmission (S/N 10542C +)

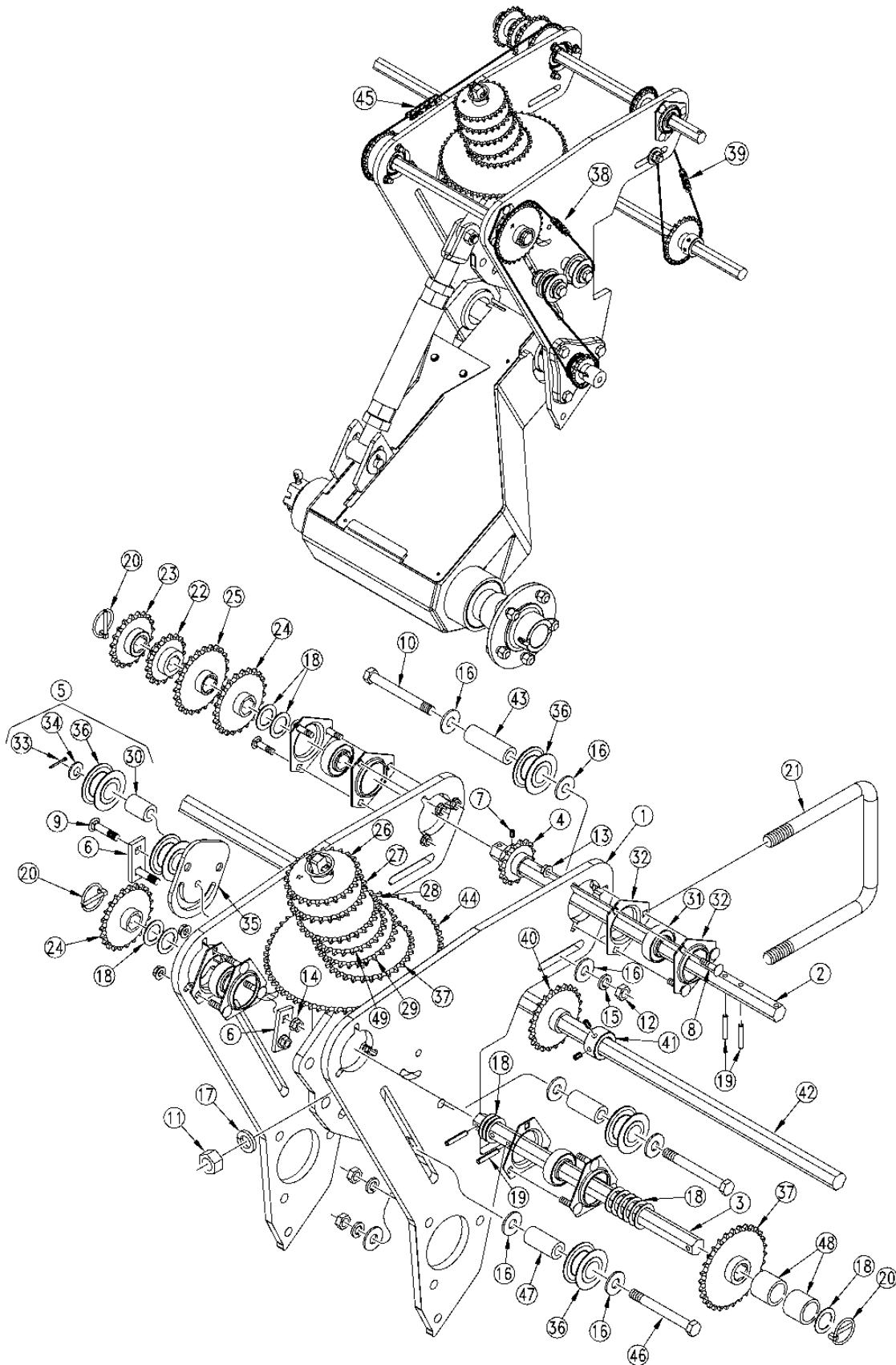

19667

Gauge Wheel Transmisson (S/N 10542C +)

Ref.	Part No.	Part Description	Comments
1.	120-276H	GW MOUNT 3PT P DRIVE	
2.	120-285D	SHAFT 7/8 HEX GW UPPER REAR	
3.	116-245D	SHAFT 7/8 HEX GW UPPER FRNT LG	
4.	120-290D	SPKT 40C15 7/8 HEX W/ SS HOLES	
5.	402-140S	DOUBLE SPOOL IDLER ASSY	
6.	402-242D	IDLER BOLT PLATE	
7.	801-035C	SCREW SET 5/16-18 SKT KP X 3/8	
8.	802-009C	RHSNB 5/16-18X1 1/4 GR5	
9.	802-252C	RHSNB 3/8-16X1 3/4 GR5	
10.	802-672C	HHCS 1/2-13X4 1/2 GR5 SPTH	
11.	803-027C	NUT HEX 3/4-10 PLT	
12.	803-036C	NUT HEX JAM 1/2-13 PLT	
13.	803-177C	NUT HEX LOCK 5/16-18 FLG.	
14.	803-209C	NUT FLANGE LOCK 3/8-16 PLT	
15.	804-015C	WASHER LOCK SPRING 1/2 PLT	
16.	804-017C	WASHER FLAT 1/2 USS PLT	
17.	804-023C	WASHER LOCK SPRING 3/4 PLT	
18.	804-061C	WASHER MACH 1.50 X 1.00 X 18GA	
19.	805-180C	PIN ROLL 1/4 X 1 1/2 LG PLT	
20.	805-240C	PIN LYNCH 3/16 X 1 9/16 LONG	
21.	806-121C	U-BOLT 3/4-10 X 7 1/32 X 7 3/4	
22.	808-148C	SPKT 40C17 X 7/8 HEX BORE	
23.	808-149C	SPKT 40C19 X 7/8 HEX BORE	
24.	808-150C	SPKT 40C23 X 7/8 HEX BORE	
25.	808-151C	SPKT 40C24 X 7/8 HEX BORE	
26.	808-152C	SPKT 40C25 X 7/8 HEX BORE	
27.	808-153C	SPKT 40C26 X 7/8 HEX BORE	
28.	808-154C	SPKT 40C27 X 7/8 HEX BORE	
29.	808-155C	SPKT 40C28 X 7/8 HEX BORE	
30.	120-305D	TUBE RND 1 OD X 7/32W X 1.56	
31.	822-119C	BRG.7/8HEX BR 52MM SPHRICAL OD	
32.	822-175C	FLANGETTE 52 3-BOLT PLT	
33.	805-064C	PIN COTTER 7/64 X 1 LONG	
34.	804-017C	WASHER FLAT 1/2 USS PLT	
35.	402-126H	OFFSET DOUBLE IDLER WELDMNT	
36.	817-406C	IDLER 1 PC 2.38X1.01X1.062	
37.	808-156C	SPKT 40C30 X 7/8 HEX BORE	
38.	136-174D	CHAIN RL #40 118 PITCHES	
39.	136-035D	REPL. BY 136-096D	
40.	808-155C	SPKT 40C28 X 7/8 HEX BORE	
41.	402-025S	LOCK COLLAR, 7/8 HEX W/ SET SC	
42.	120-291D	SHAFT 7/8 HEX, 88.0 LONG PLTD	
	120-307D	76" LONG SHAFT(TWIN ROW ONLY)	
43.	120-293D	TUBE RND DOM. 1 OD X 7/32WX3.0	
44.	195-172H	SPKT 40C60 X 7/8 HEX BORE	
45.	136-058D	CHAIN RL #40 102 PITCHES	
46.	802-201C	HHCS 1/2-13X4 3/4 GR5	
47.	120-313D	TUBE RND 1 OD X 7/32W X 3.31	
48.	120-315D	SPACER TUBE 1 ID X 1.25	
49.	808-276C	SPKT 40C20 X 7/8 HEX BORE	

Legend: ● = 1st revision; ● = 2nd revision; ● = 3rd revision; ● = use up existing stock; ⊗ = not interchangeable; ⊗ ① ● = for example: revision 2 is not interchangeable w/revision 1

10 Series Opener Arms & Mounts (S/N 10513C -)

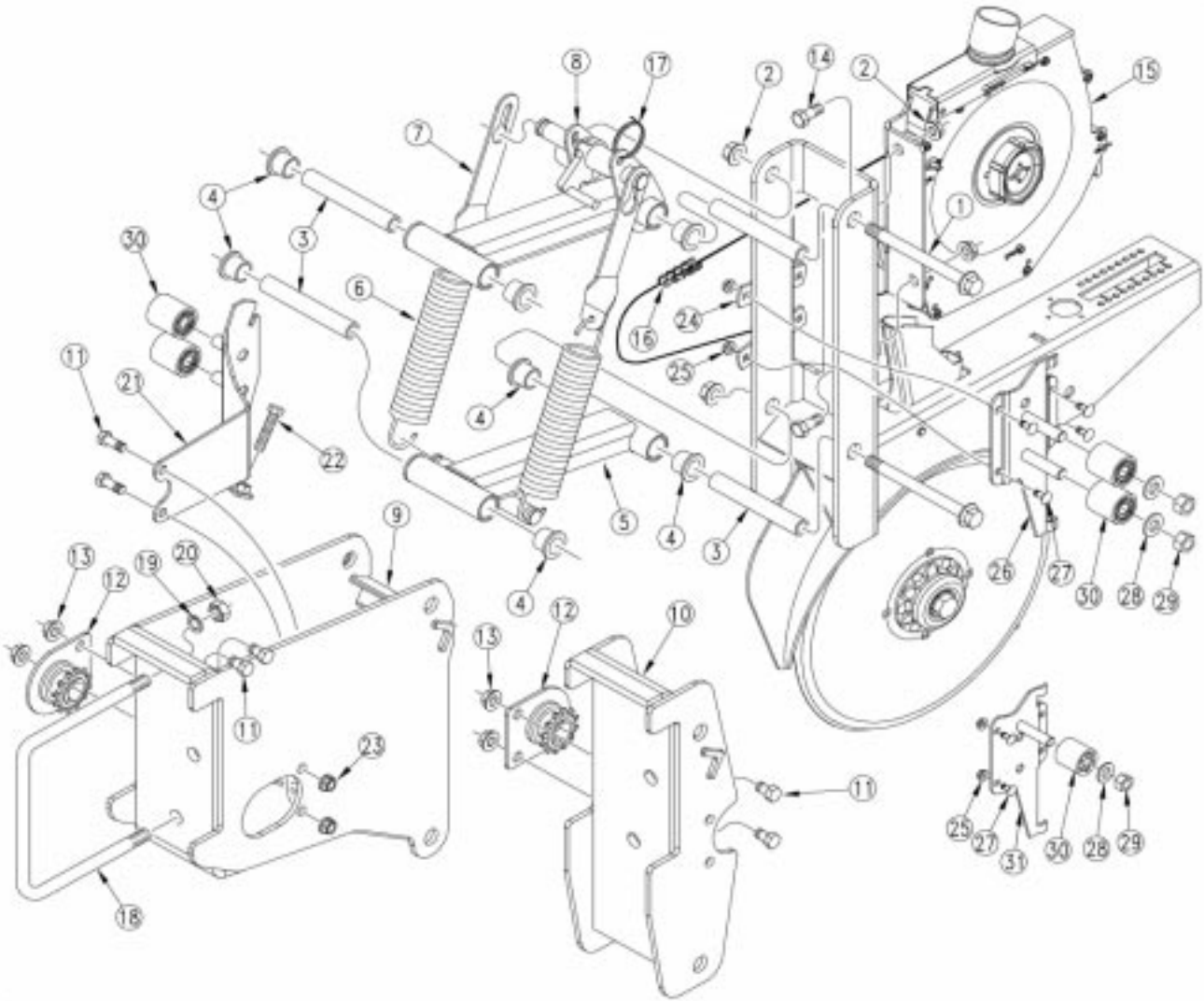

10 Series Opener Arms & Mounts (S/N 10513C -)

Ref.	Part No.	Part Description	Comments
1.	802-419C	HFS 1/2-13X5 3/4	
2.	803-169C	NUT HEX FLG. LOCK 1/2-13 PLT.	
3.	198-246D	SING OPENER INNER PIVOT TUBE	
4.	817-084C	PARALLEL ARM PIVOT BUSHING	
5.	198-619H	SING OPENER LOWER ARM WELDMENT	
6.	807-116C	SPRING EXT 1 5/8OD X 6.6X.177	
7.	198-239D	6 15/16 SPRING STRAP	
8.	198-618H	SING OPENER UPPER ARM WELDMENT	
9.	198-614H	PSS OPENER MOUNT REAR WLDMT	
10.	198-613H	PSS OPENER MOUNT FRONT WLDMT	
11.	802-017C	HHCS 3/8-16X1 GR5	
12.	403-059D	SPKT 41B12 7/8 HEX W/BEARING	
13.	803-209C	NUT FLANGE LOCK 3/8-16 PLT	
14.	802-258C	HHCS 1/2-13X1 GR5	
15.	403-104K	PSS METER ASSEMBLY	
16.	136-160D	CHAIN RL #41 81PITCHES	Front Opener.
	136-159D	CHAIN RL #41 124 PITCHES	Rear Opener.
17.	800-303C	CABLE TIE 2 DIA MIN - BLK	Used with monitor seed tubes.
18.	806-053C	U-BOLT 5/8-11 X 7 1/32 X 6 1/2	
19.	804-022C	WASHER LOCK SPRING 5/8 PLT	
20.	803-021C	NUT HEX 5/8-11 PLT	
21.	198-949H	IDLER BRKT, FRONT	
22.	802-620C	HHCS 3/8-16X1 3/4 FULL THD PLT	
23.	803-198C	NUT HEX WHIZ 3/8-16 PLT	
24.	198-254D	IDLER BRACKET, REAR,BOLT STRAP	
25.	803-194C	NUT HEX WHIZ 1/4-20 PLT	
26.	198-948H	IDLER BRKT, REAR, REAR STAGGER	Rear Opener
27.	802-002C	RHSNB 1/4-20X3/4 GR5	
28.	804-016C	WASHER FLAT 1/2 SAE PLT	
29.	803-019C	NUT LOCK 1/2-13 PLT	
30.	817-480C	IDLER SPOOL 1.44OD X.53B X1.5L	
31.	198-947H	IDLER BRKT, REAR, FRNT STAGGER	Front Opener

5

Legend: ● = 1st revision; ● = 2nd revision; ● = 3rd revision; ● = use up existing stock; ⊗ = not interchangeable; ⊗ ① ● = for example: revision 2 is not interchangeable w/revision 1

10 Series Opener Arms & Mounts (S/N 10542C +)

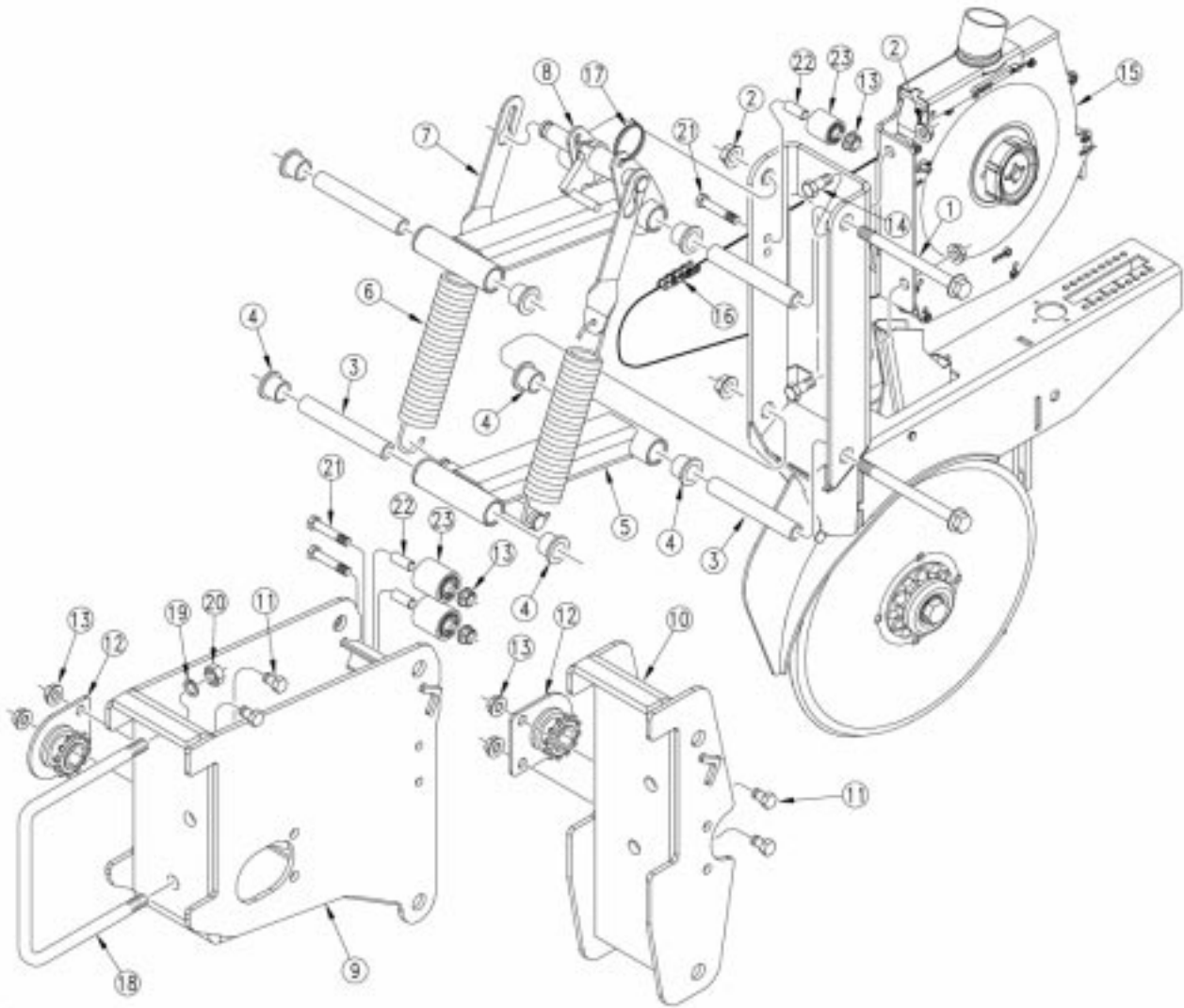

10 Series Opener Arms & Mounts (S/N 10542C +)

Ref.	Part No.	Part Description	Comments
1.	802-419C	HFS 1/2-13X5 3/4	
2.	803-169C	NUT HEX FLG. LOCK 1/2-13 PLT.	
3.	198-246D	SING OPENER INNER PIVOT TUBE	
4.	817-084C	PARALLEL ARM PIVOT BUSHING	
5.	198-619H	SING OPENER LOWER ARM WELDMENT	
6.	807-116C	SPRING EXT 1 5/8OD X 6.6X.177	
7.	198-239D	6 15/16 SPRING STRAP	
8.	198-618H	SING OPENER UPPER ARM WELDMENT	
9.	198-614H	PSS OPENER MOUNT REAR WLDMT	
10.	198-613H	PSS OPENER MOUNT FRONT WLDMT	
11.	802-017C	HHCS 3/8-16X1 GR5	
12.	403-059D	SPKT 41B12 7/8 HEX W/BEARING	
13.	803-209C	NUT FLANGE LOCK 3/8-16 PLT	
14.	802-258C	HHCS 1/2-13X1 GR5	
15.	403-104K	PSS METER ASSEMBLY	
16.	136-160D	CHAIN RL #41 81PITCHES	Front Opener.
	136-159D	CHAIN RL #41 124 PITCHES	Rear Opener.
17.	800-303C	CABLE TIE 2 DIA MIN - BLK	Used with monitor seed tubes.
18.	806-053C	U-BOLT 5/8-11 X 7 1/32 X 6 1/2	
19.	804-022C	WASHER LOCK SPRING 5/8 PLT	
20.	803-021C	NUT HEX 5/8-11 PLT	
21.	802-114C	HHCS 3/8-16X2 1/2 GR5	
22.	198-257D	IDLER SPACER TUBE 1/2OD X 1.56	
23.	817-480C	IDLER SPOOL 1.44OD X.53B X1.5L	

Legend: ● = 1st revision; ● = 2nd revision; ● = 3rd revision; ● = use up existing stock; ⊗ = not interchangeable; ⊗ ① ● = for example: revision 2 is not interchangeable w/revision 1

10 Series Opener Body (S/N 10679C-)

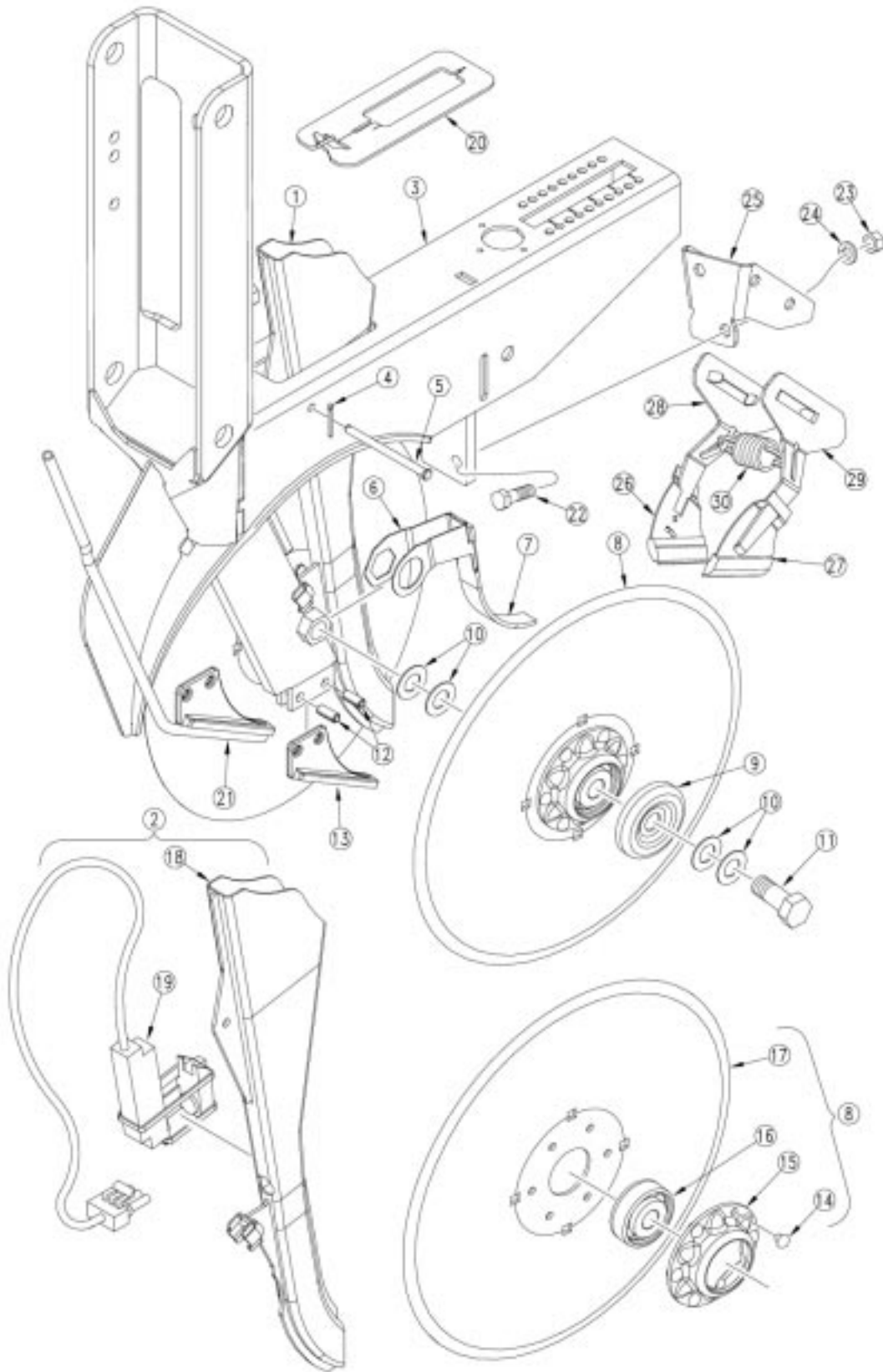

10 Series Opener Body (S/N 10679C-)

Ref.	Part No.	Part Description	Comments
1.	817-413C	SEED DROP TUBE NO SENSOR HOLE	
2.	198-738S	SEED TUBE W/DJ SENSOR 10&20	Includes 18 & 19
3.	198-616H	10 SERIES SINGULATING OPENER	If S/N 10512C and below, part #13 (812-298C) or part #21 (122-258C) must also be ordered
4.	805-063C	PIN COTTER 3/32 X 1	
5.	805-299C	PIN CLEVIS 1/4 X 3 23/64 USBL	
6.	198-241D	SEED FLAP MOUNTING CLIP, SING	
7.	816-302C 817-349C	SEED FLAP, RUBBER, SEED-LOK SEED FLAP, UHMW, LONG	Used with Seed-Lok (shown). Used without Seed-Lok.
8.	107-133S	D.D. W/ 205 BRG ASSY-PLT FLNG	Includes 14,15,16 & 17
9.	107-111D	DD BRG FLANGE DUST COVER	
10.	804-040C	WASHER MACH 1.19 X .63 X 18GA	
11.	802-228C	HHCS 5/8-11X1 1/2 GR5 NYL	
12.	805-280C	PIN ROLL 5/16 X 3/4 PLT	
13.	812-298C 812-297C	SCRAPER-SPREADER 10 SER 2002+ SCRAPER-SPREADER 10-20SER 1999	S/N 10542C+ S/N 10512C-
14.	800-213C	RIVET,BUTTON HEAD 1/4 X 9/16	
15.	890-466C	RIBB BRG FLNG .266 MT HOLE PLT	
16.	188-001V	BEARING AA205DD	
17.	820-155C	FLAT DISK STEEL	
18.	817-396C	SEED DROP TUBE W/ SENSOR HOLE	
19.	833-222C	DJ PLANTER STYLE SEED SENSOR	
20.	816-383C	SEED TUBE GASKET, 10 SERIES	
21.	122-257H 122-258H	SEP &FERT TUBE 10-20SER 1999 SEP &FERT TUBE 10 SER 2002+	Option S/N 10512C- Option S/N 10542C+
22.	802-079C	HHCS 3/8-16X1 1/4 GR5	
23.	803-014C	NUT HEX 3/8-16 PLT	
24.	804-013C	WASHER LOCK SPRING 3/8 PLT	
25.	122-169D	10P AD OUTSIDE SCRAPER MOUNT	
26.	AD21010	AIR DESIGN SCRAPER J.D.2.5W RH	
27.	AD21011	AIR DESIGN SCRAPER J.D.2.5W LH	
28.	AD21012	AIR DESIGN SCRAPER J.D.MNT RH	
29.	AD21013	AIR DESIGN SCRAPER J.D.MNT LH	
30.	AD21014	AIR DESIGN SCRAPER J.D.SPRING	



Legend: ● = 1st revision; ● = 2nd revision; ● = 3rd revision; ● = use up existing stock; ⊗ = not interchangeable; ⊗ ① ● = for example: revision 2 is not interchangeable w/revision 1

10 Series Opener Body (S/N 10680C+)

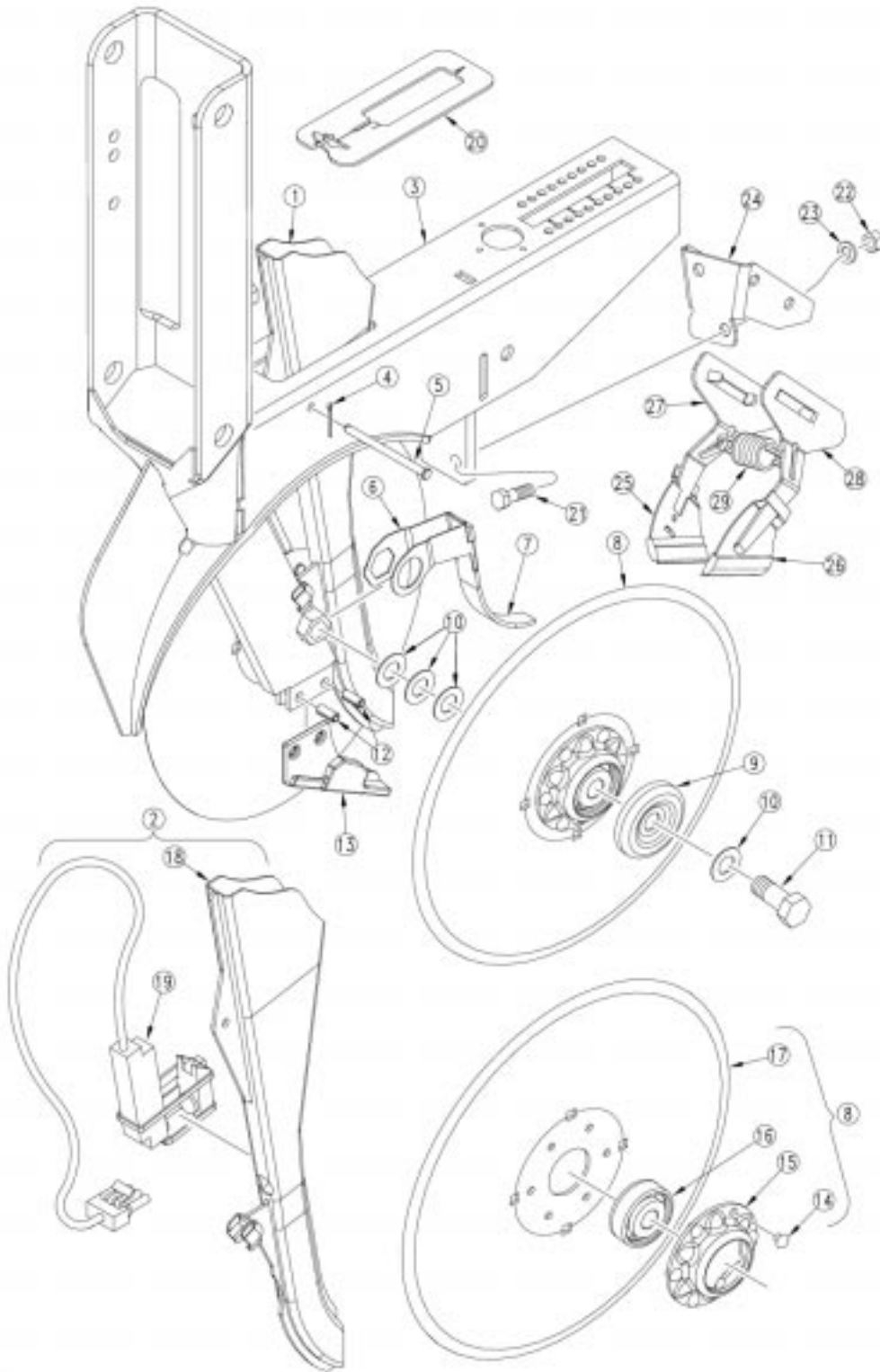

10 Series Opener Body (S/N 10680C+)

Ref.	Part No.	Part Description	Comments
1.	817-413C	SEED DROP TUBE NO SENSOR HOLE	
2.	198-738S	SEED TUBE W/DJ SENSOR 10&20	
3.	198-616H	10 SERIES SINGULATING OPENER	
4.	805-063C	PIN COTTER 3/32 X 1 LONG	
5.	805-299C	PIN CLEVIS 1/4 X 3 23/64 USBL	
6.	198-241D	SEED FLAP MOUNTING CLIP, SING	
7.	816-302C	SEED FLAP, RUBBER, SEED-LOK	
	817-349C	SEED FLAP, UHMW, LONG	
8.	107-138S	DD W/205 BRG-PLD FLNG-4MM	
9.	107-111D	DD BRG FLANGE DUST COVER	
10.	804-040C	WASHER MACH 1.19 X .63 X 18GA	
11.	802-228C	HHCS 5/8-11X1 1/2 GR5 NYL	
12.	805-335C	PIN ROLL 5/16 X 5/8 PLT	
13.	812-309C	SCRAPER-SPREADER 10-20SER 2003	
14.	800-213C	RIVET,BUTTON HEAD 1/4 X 1/2	
15.	890-466C	RIBB BRG FLNG .266 MT HOLE PLT	
16.	188-001V	BEARING AA205DD	
17.	820-256C	FLAT DISK BLADE-4MM THICK	
18.	817-396C	SEED DROP TUBE W/ SENSOR HOLE	
19.	833-222C	DJ PLANTER STYLE SEED SENSOR	
20.	816-383C	SEED TUBE GASKET, 10 SERIES	
21.	802-079C	HHCS 3/8-16X1 1/4 GR5	
22.	803-014C	NUT HEX 3/8-16 PLT	
23.	804-013C	WASHER LOCK SPRING 3/8 PLT	
24.	122-169D	10P AD OUTSIDE SCRAPER MOUNT	
25.	AD21010	AIR DESIGN SCRAPER J.D.2.5W RH	
26.	AD21011	AIR DESIGN SCRAPER J.D.2.5W LH	
27.	AD21012	AIR DESIGN SCRAPER J.D.MNT RH	
28.	AD21013	AIR DESIGN SCRAPER J.D.MNT LH	
29.	AD21014	AIR DESIGN SCRAPER J.D.SPRING	

Legend: ● = 1st revision; ● = 2nd revision; ● = 3rd revision; ● = use up existing stock; ⊗ = not interchangeable; ⊗ ① ● = for example: revision 2 is not interchangeable w/revision 1

20 Series Opener Arms & Mounts (S/N 10513C -)

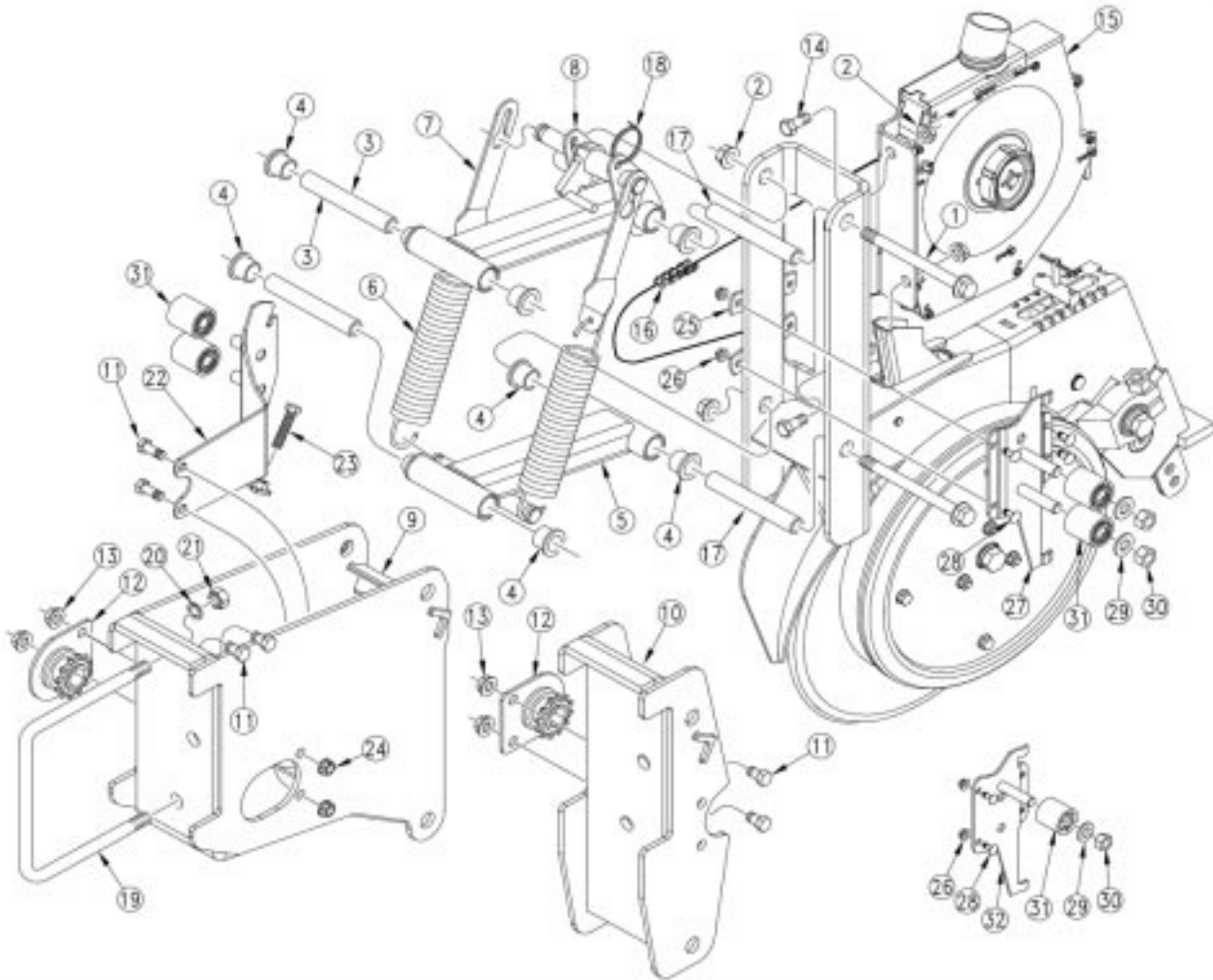

20 Series Opener Arms & Mounts (S/N 10513C -)

Ref.	Part No.	Part Description	Comments
1.	802-419C	HFS 1/2-13X5 3/4	
2.	803-169C	NUT HEX FLG. LOCK 1/2-13 PLT.	
3.	198-246D	SING OPENER INNER PIVOT TUBE	
4.	817-084C	PARALLEL ARM PIVOT BUSHING	
5.	198-619H	SING OPENER LOWER ARM WELDMENT	
6.	807-116C	SPRING EXT 1 5/8OD X 6.6X.177	Used with 1x12 Press Wheels.
	807-076C	SPRING EXT 1.575 OD X .225 W	Used with 1x10 Press Wheels.
7.	198-239D	6 15/16 SPRING STRAP	Used with 807-116C.
	198-240D	3 13/32 SPRING STRAP	Used with 807-076C.
8.	198-618H	SING OPENER UPPER ARM WELDMENT	
9.	198-614H	PSS OPENER MOUNT REAR WLDMT	
10.	198-613H	PSS OPENER MOUNT FRONT WLDMT	
11.	802-017C	HHCS 3/8-16X1 GR5	
12.	403-059D	SPKT 41B12 7/8 HEX W/BEARING	
13.	803-209C	NUT FLANGE LOCK 3/8-16 PLT	
14.	802-258C	HHCS 1/2-13X1 GR5	
15.	403-104K	PSS METER ASSEMBLY	
16.	136-160D	CHAIN RL #41 81 PITCHES	Front openers.
	136-159D	CHAIN RL #41 124 PITCHES	Rear openers.
17.	198-247D	20 SER SING FRT INNER PIVOT TB	
18.	800-303C	CABLE TIE 2 DIA MIN - BLK	Used with monitor seed tubes.
19.	806-053C	U-BOLT 5/8-11 X 7 1/32 X 6 1/2	
20.	804-022C	WASHER LOCK SPRING 5/8 PLT	
21.	803-021C	NUT HEX 5/8-11 PLT	
22.	198-949H	IDLER BRKT, FRONT	
23.	802-620C	HHCS 3/8-16X1 3/4 FULL THD PLT	
24.	803-198C	NUT HEX WHIZ 3/8-16 PLT	
25.	198-254D	IDLER BRACKET, REAR,BOLT STRAP	
26.	803-194C	NUT HEX WHIZ 1/4-20 PLT	
27.	198-948H	IDLER BRKT, REAR, REAR STAGGER	Rear openers
28.	802-002C	RHSNB 1/4-20X3/4 GR5	
29.	804-016C	WASHER FLAT 1/2 SAE PLT	
30.	803-019C	NUT LOCK 1/2-13 PLT	
31.	817-480C	IDLER SPOOL 1.44OD X.53B X1.5L	
32.	198-947H	IDLER BRKT, REAR, FRNT STAGGER	Front openers

Legend: ● = 1st revision; ● = 2nd revision; ● = 3rd revision; ● = use up existing stock; ⊗ = not interchangeable; ⊗ ① ● = for example: revision 2 is not interchangeable w/revision 1

20 Series Opener Arms & Mounts (S/N 10542C+)

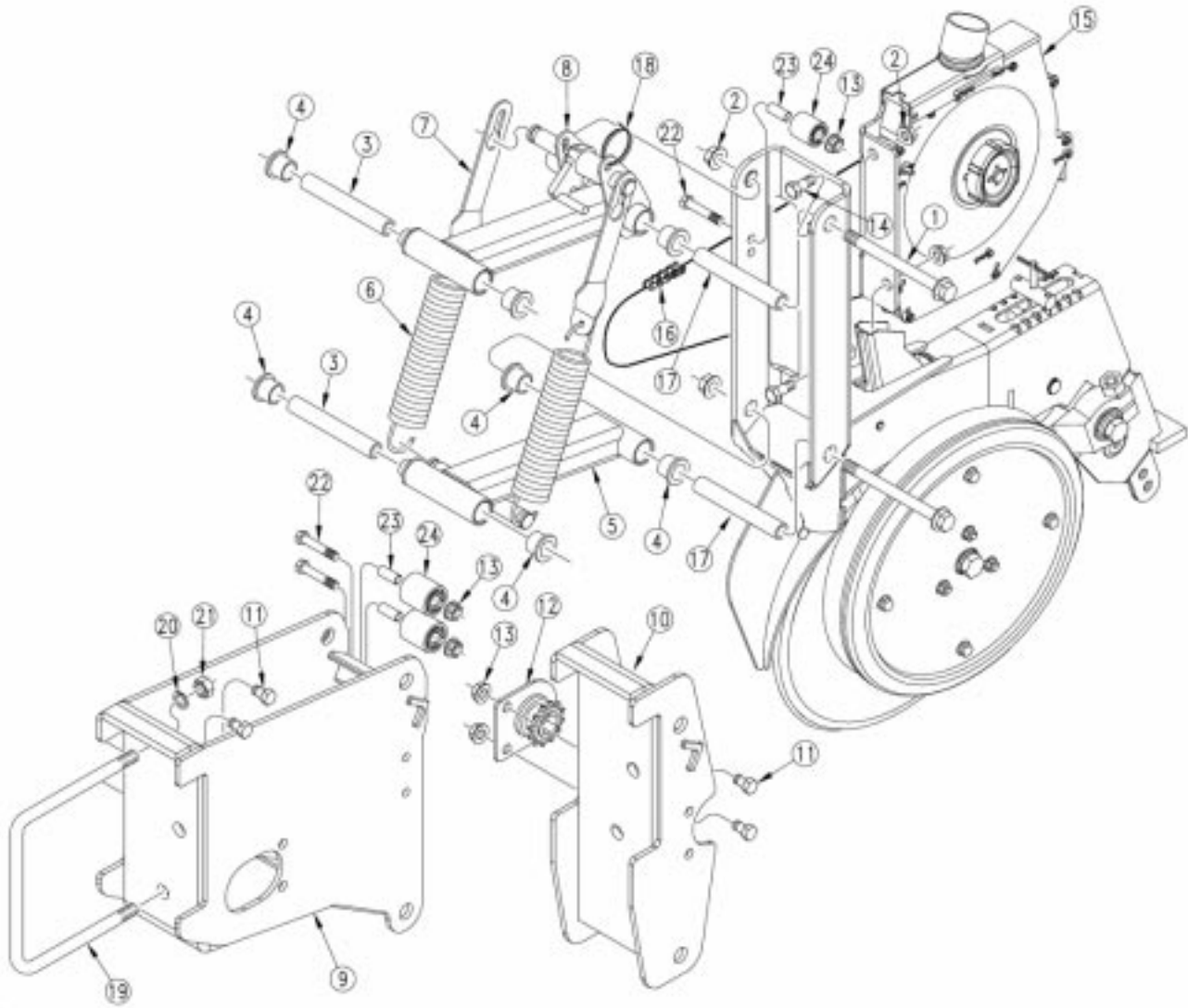

20 Series Opener Arms & Mounts (S/N 10542C+)

Ref.	Part No.	Part Description	Comments
1.	802-419C	HFS 1/2-13X5 3/4	
2.	803-169C	NUT HEX FLG. LOCK 1/2-13 PLT.	
3.	198-246D	SING OPENER INNER PIVOT TUBE	
4.	817-084C	PARALLEL ARM PIVOT BUSHING	
5.	198-619H	SING OPENER LOWER ARM WELDMENT	
6.	807-116C	SPRING EXT 1 5/8OD X 6.6X.177	Used with 1x12 Press Wheels.
	807-076C	SPRING EXT 1.575 OD X .225 W	Used with 1x10 Press Wheels.
7.	198-239D	6 15/16 SPRING STRAP	Used with 807-116C.
	198-240D	3 13/32 SPRING STRAP	Used with 807-076C.
8.	198-618H	SING OPENER UPPER ARM WELDMENT	
9.	198-614H	PSS OPENER MOUNT REAR WLDMT	
10.	198-613H	PSS OPENER MOUNT FRONT WLDMT	
11.	802-017C	HHCS 3/8-16X1 GR5	
12.	403-059D	SPKT 41B12 7/8 HEX W/BEARING	
13.	803-209C	NUT FLANGE LOCK 3/8-16 PLT	
14.	802-258C	HHCS 1/2-13X1 GR5	
15.	403-104K	PSS METER ASSEMBLY	
16.	136-160D	CHAIN RL #41 81 PITCHES	Front openers.
	136-159D	CHAIN RL #41 124 PITCHES	Rear openers.
17.	198-247D	20 SER SING FRT INNER PIVOT TB	
18.	800-303C	CABLE TIE 2 DIA MIN - BLK	Used with monitor seed tubes.
19.	806-053C	U-BOLT 5/8-11 X 7 1/32 X 6 1/2	
20.	804-022C	WASHER LOCK SPRING 5/8 PLT	
21.	803-021C	NUT HEX 5/8-11 PLT	
22.	802-114C	HHCS 3/8-16X2 1/2 GR5	
23.	198-257D	IDLER SPACER TUBE 1/2OD X 1.56	
24.	817-480C	IDLER SPOOL 1.44OD X.53B X1.5L	

Legend: ● = 1st revision; ● = 2nd revision; ● = 3rd revision; ● = use up existing stock; ⊗ = not interchangeable; ⊗ ① ● = for example: revision 2 is not interchangeable w/revision 1

20 Series Opener Body

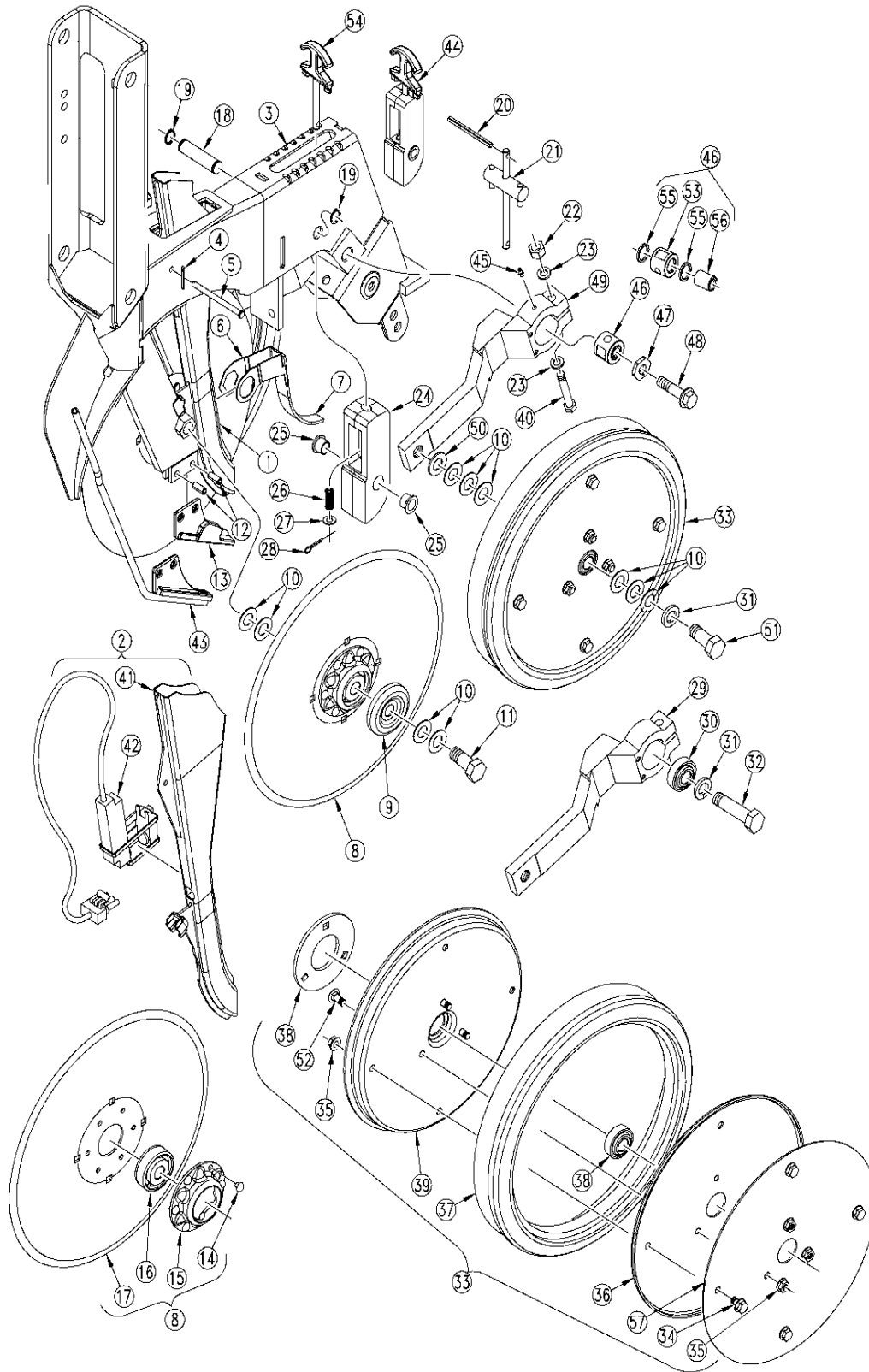

20 Series Opener Body

Ref.	Part No.	Part Description	Comments
1.	817-413C	SEED DROP TUBE NO SENSOR HOLE	
2.	198-738S	SEED TUBE W/DJ SENSOR 10&20	Includes 42 & 43
3.	198-615H	20 SERIES SINGULATING OPENER	
4.	805-063C	PIN COTTER 3/32 X 1	
5.	805-296C	PIN CLEVIS 1/4 X 1 31/64 USBL	
6.	198-241D	SEED FLAP MOUNTING CLIP, SING	
7.	816-302C	SEED FLAP, RUBBER, SEED-LOK	Used with Seed-Lok (shown).
	817-349C	SEED FLAP, UHMW, LONG	Used without Seed-Lok.
8.	107-138S	DD W/205 BRG-PLD FLNG-4MM	S/N 10715C+
	107-133S	D.D. W/ 205 BRG ASSY-PLT FLNG	S/N 10714C-
9.	107-111D	DD BRG FLANGE DUST COVER	
10.	804-040C	WASHER MACH 1.19 X .63 X 18GA	
11.	802-228C	HHCS 5/8-11X1 1/2 GR5 NYL	
12.	805-335C	PIN ROLL 5/16 X 5/8 PLT	S/N 10715C+
	805-280C	PIN ROLL 5/16 X 3/4 PLT	S/N 10714C-
13.	812-309C	SCRAPER-SPREADER 10-20SER 2003	S/N 10715C+
	812-297C	SCRAPER-SPREADER 10-20SER 1999	S/N 10714C-
14.	800-213C	RIVET,BUTTON HEAD 1/4 X 9/16	
15.	890-466C	RIBB BRG FLNG .266 MT HOLE PLT	
16.	188-001V	BEARING AA205DD	
17.	820-256C	FLAT DISK BLADE-4MM THICK	S/N 10715C+
	820-155C	FLAT DISK STEEL	S/N 10714C-
18.	198-202D	20 SER OPNR CAM PIN	
19.	800-118C	SNAP RING EXT 5/8 .050 T	
20.	805-062C	PIN ROLL 3/16 X 2 1/2 LG. PTL.	S/N 10714C-
21.	198-497H	20 SER OPENER T-HANDLE WLDMNT	S/N 10714C-
22.	803-307C	NUT HEX 7/16-20 GR8	
23.	804-014C	WASHER LOCK 7/16 PLT	
24.	198-201D	20 SER OPNR PW CAM	
25.	817-083C	PRESS WHEEL ARM PIVOT BUSHING	
26.	807-172C	SPRING COMP 5/8 OD X 1 3/4 LG	
27.	804-012C	WASHER FLAT 3/8 SAE PLT	
28.	805-067C	PIN COTTER 1/8 X 3/4	
29.	198-248D	20 SERIES OPNR DEPTH WHEEL ARM	S/N 10714C-
30.	822-095C	BEARING DBL LIP 203 X 5/8 BORE	S/N 10714C-
31.	804-022C	WASHER LOCK SPRING 5/8 PLT	
32.	802-366C	HHCS 5/8-11X2 1/2 GR5 NYL	S/N 10714C-
33.	198-057S	2X13 DEPTH WHEEL ASSY	Includes 34,35,36,37,40, 52 & 57
34.	802-352C	HFSS 5/16-18X1/2 GR5	
35.	803-043C	NUT HEX WHIZ 5/16-18 PLT	
36.	814-082C	2X13 D.W. OUTER RIM HALF	
37.	814-083C	2X13 SIDE DEPTH TIRE	
38.	198-183D	20 SER SIDE DEPTH WL STIFF PLT	
39.	814-081C	2X13 D.W. INNER RIM HALF	
40.	802-694C	HHCS 7/16-20 2 3/4 GR8	
41.	817-396C	SEED DROP TUBE W/ SENSOR HOLE	
42.	833-222C	DJ PLANTER STYLE SEED SENSOR	
43.	122-257H	SEP &FERT TUBE 10-20SER 1999	Option
44.	198-956K	20 SER OPENER T-HANDLE SUBASSY	S/N 10715C+
45.	800-001C	GREASE ZERK STRAIGHT 1/4-28	
46.	198-999S	20P LH ELIMINATOR BUSHING ASSY	S/N 10715C+ (Shown)
	198-998S	20P RH ELIMINATOR BUSHING ASSY	S/N 10715C+
47.	298-324S	20P DPTH WHL ECCENTRIC ADJUSTR	S/N 10715C+
48.	802-729C	HFS 5/8-11X2 1/2 GR8 PLT	S/N 10715C+
49.	198-265D	20P SIDE DEPTH WHEEL ARM	S/N 10715C+
50.	804-195C	WASHER FLAT 1.31ODX.65IDX.188T	S/N 10715C+
51.	802-430C	HHCS 5/8-11X2 GR5 NYL	S/N 10715C+
52.	802-092C	RHSNB 5/16-18X3/4 GR5	
53.	198-267D	20P DEPTH WHL OUTER BUSHING	
54.	812-302C	CASTING - STAINLESS T-HANDLE	
55.	816-414C	O-RING SQUARE 1IDX1 1/4ODX1/8	
56.	198-266D	20P DEPTH WHL ECCENTRIC BUSHNG	
57.	198-305D	WHEEL REINFORCING PLATE	

Legend: ● = 1st revision; ● = 2nd revision; ● = 3rd revision; ● = use up existing stock; ⊗ = not interchangeable; ⊗ ⊕ ● = for example: revision 2 is not interchangeable w/revision 1

Keeton Seed Firmer (Option)

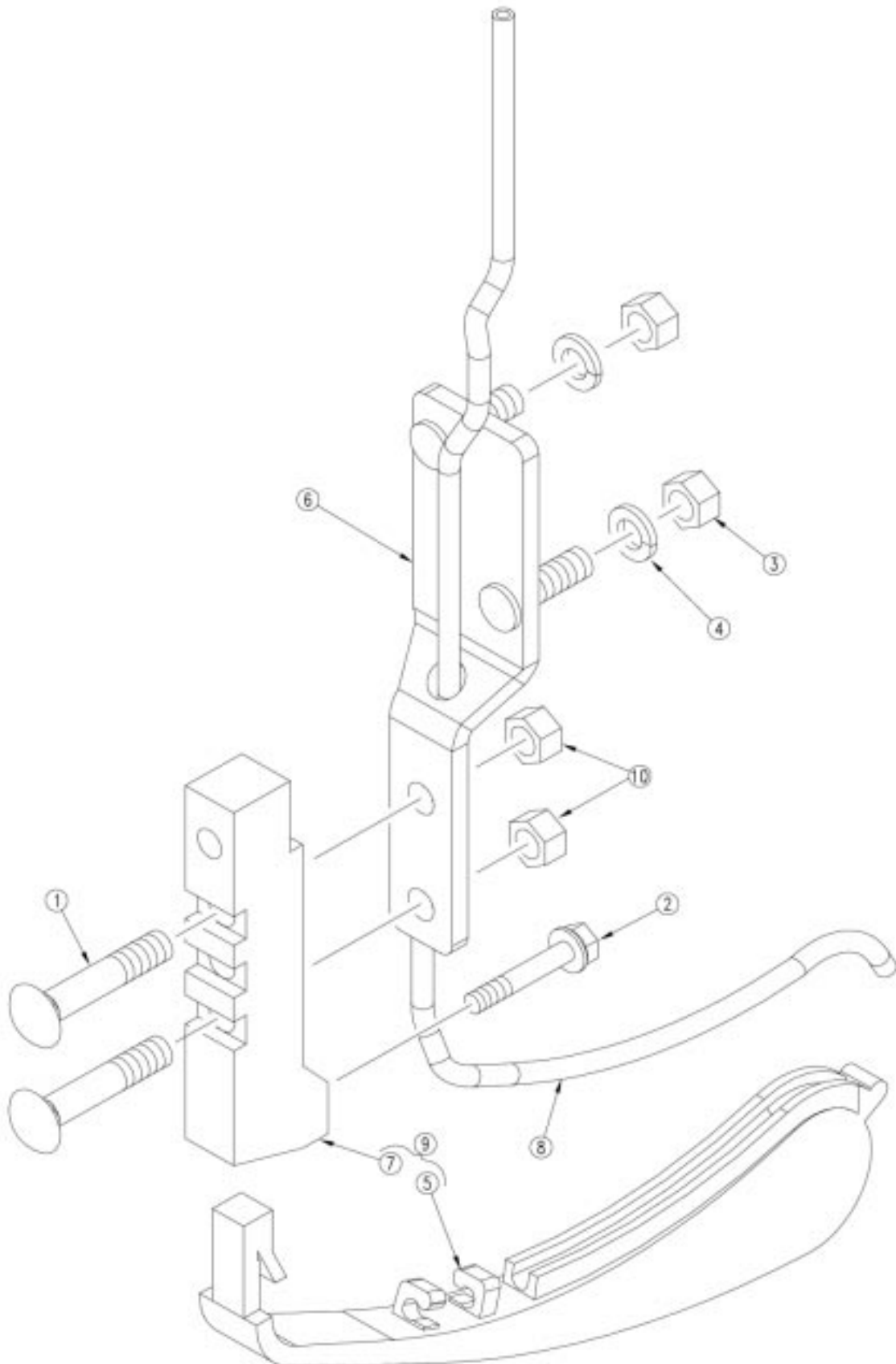

20252

Keeton Seed Firmer (Option)

Ref.	Part No.	Part Description	Comments
1.	802-411C	RHSNB 3/8-16X2 GR5	
2.	802-617C	HHFS 1/4-20 X 1 1/2 GR 5	
3.	803-014C	NUT HEX 3/8-16 PLT	
4.	804-013C	WASHER LOCK SPRING 3/8 PLT	
5.	129BXT810	KEETON FIRMER	
6.	150GP022E	STEEL MOUNTING BRACKET	
7.	129BXT811	KEETON POLY BRACKET	
8.	900TUBE BL	KEETON FERTILIZER TUBE	
9.	129BXT800	KEETON REPLCMNT FIRMERW/TUBING	
10.	803-013C	NUT LOCK 3/8-16 PLT	

Legend: ● = 1st revision; ● = 2nd revision; ● = 3rd revision; ● = use up existing stock; ⊗ = not interchangeable; ⊗ ① ● = for example: revision 2 is not interchangeable w/revision 1

Air Design Scraper (Option)

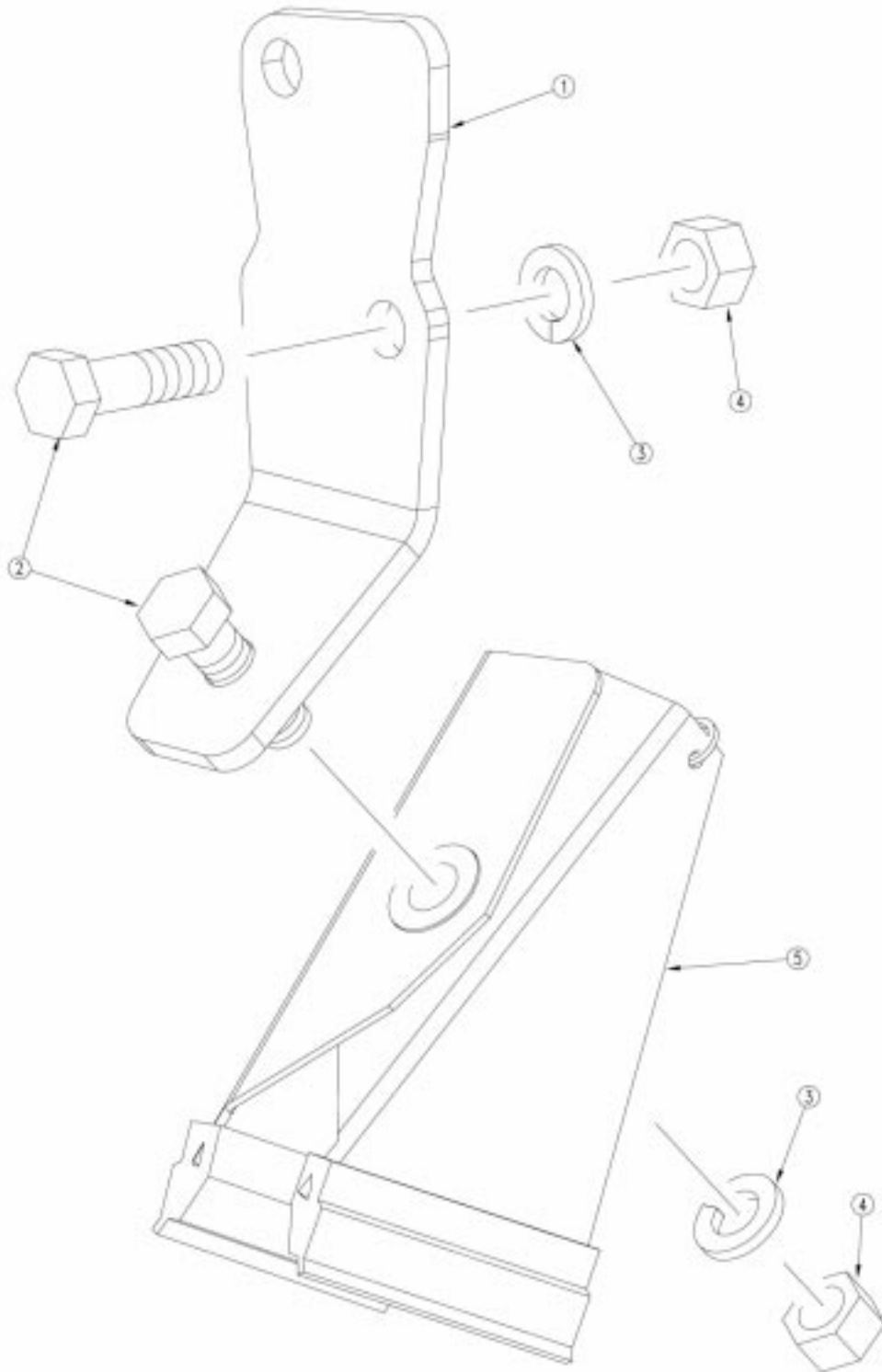

20434

Air Design Scraper (Option)

Ref.	Part No.	Part Description	Comments
1.	122-168D	10P20P AD INSIDE SCRAPER MOUNT	
2.	802-079C	HHCS 3/8-16X1 1/4 GR5	
3.	804-013C	WASHER LOCK SPRING 3/8 PLT	
4.	803-014C	NUT HEX 3/8-16 PLT	
5.	890-357C	SCRAPER-SPRING LOAD-AIR DESIGN	

Side Wheel Scraper (Option)

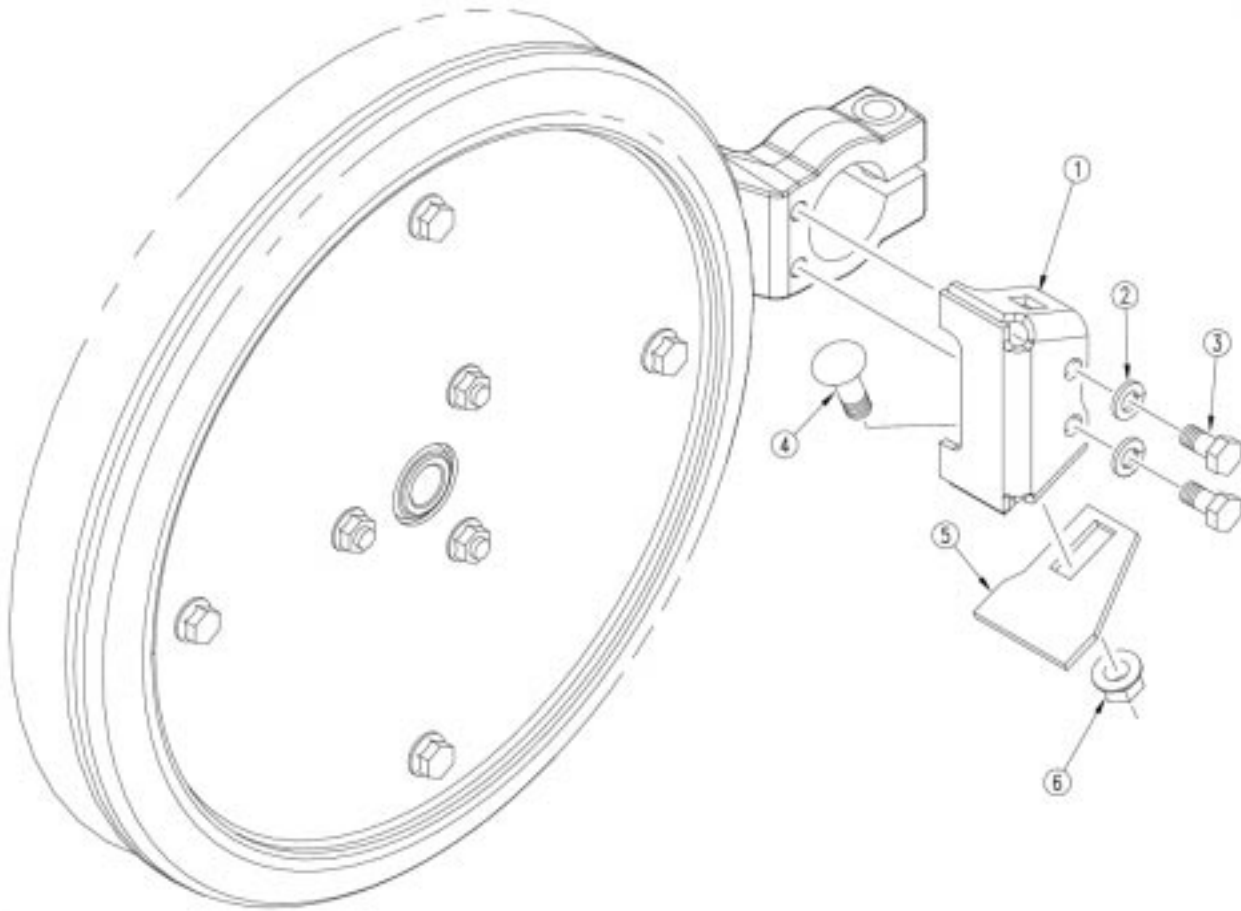

Side Wheel Scraper (Option)

Ref.	Part No.	Part Description	Comments
1.	198-264D	20P SIDE WHEEL SCRAPER MOUNT	
2.	804-009C	WASHER LOCK SPRING 5/16 PLT	
3.	802-705C	HHCS 5/16-18X5/8	
4.	802-149C	RHSNB 3/8-16X3/4 GR5	
5.	198-263D	20P SIDE WHEEL SCRAPER	
6.	803-209C	NUT FLANGE LOCK 3/8-16 PLT	

10 & 20 Series Seed-Lok (Option)

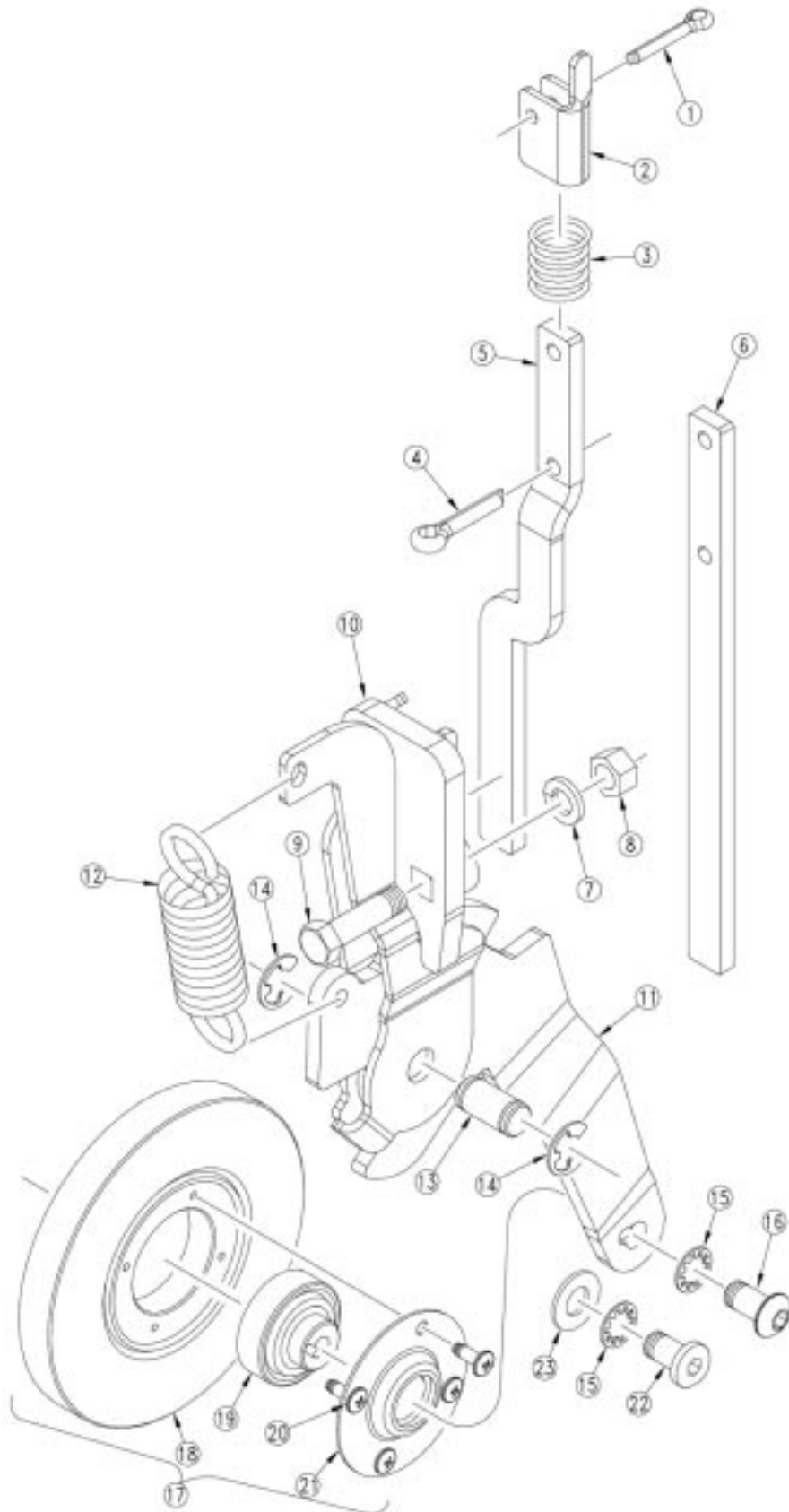

20039

10 & 20 Series Seed-Lok (Option)

Ref.	Part No.	Part Description	Comments
1.	805-069C	PIN COTTER 3/16 X 1	
2.	122-166D	SEED LOCK LOCK-UP CAM	
3.	807-188C	SPRING COMP .85ODX2.0LGX.067W	
4.	805-020C	PIN COTTER 1/4 X 1 PLT	
5.	122-167D	10 SER SEED LOCK LOCK-UP BAR	Shown.
6.	122-165D	20 SER SEED LOCK LOCK-UP BAR	
7.	804-013C	WASHER LOCK SPRING 3/8 PLT	
8.	803-014C	NUT HEX 3/8-16 PLT	
9.	802-022C	HHCS 3/8-16X1 1/2 GR5	
10.	122-250H	SEED LOCK MOUNT, SINGULATING	
11.	122-164D	SEED LOCK ARM, SINGULATING	
12.	807-101C	SPRING, 1 O.D.X.125WIREX 3 1/2	
13.	122-120D	5 SEED-LOK WHL ARM PIVOT PIN	
14.	800-093C	SNAP RING EXT E 1/2	
15.	804-078C	WASHER INTERNAL STAR 3/8 PLT.	
16.	801-078C	SCR HX SKT BUT CP 3/8-16X3/4	20 Series only.
17.	122-201S	SD-LK 203 BEARING WHEEL ASSY	Includes 18,19,20 & 21
18.	817-134C	5/8 X 5 SEED FIRING WHEEL	
19.	188-008V	BEARING 203 SEED-LOK WITH PIN	
20.	801-084C	SCR PH THD FMG #10X1/2 TP ZP	
21.	816-173C	BEARING RETAINER W/BONDED SEAL	
22.	801-141C	LHS CP 3/8-16X3/4 GR8 PLAIN	10 Series only.
23.	804-011C	WASHER FLAT 3/8 USS PLT	10 Series only.



Legend: ● = 1st revision; ● = 2nd revision; ● = 3rd revision; ● = use up existing stock; ⊗ = not interchangeable; ⊗ ① ● = for example: revision 2 is not interchangeable w/revision 1

2" x 13" Single Press Wheel

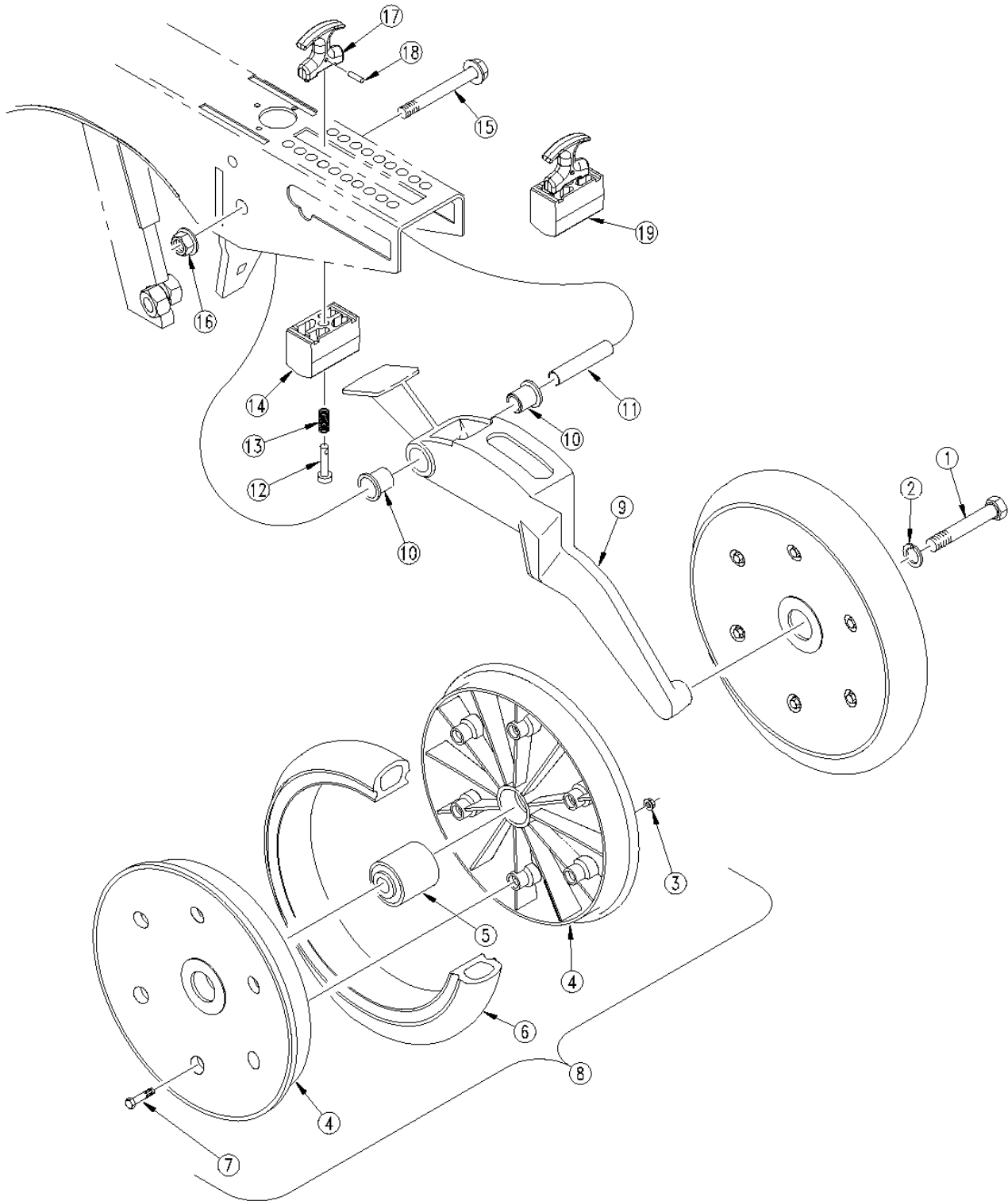

2" x 13" Single Press Wheel

Ref.	Part No.	Part Description	Comments
1.	802-058C	HHCS 5/8-11X2 1/2 GR5	
2.	804-022C	WASHER LOCK SPRING 5/8 PLT	
3.	803-088C	NUT HEX LOCK 1/4-20 FLG	
4.	817-296C	2 X 13 PRESS WHEEL RIM HALF	
5.	822-170C	BEARING PRESS WHEEL ASSEMBLY	
6.	814-159C	2 X 13 PRESS WHEEL TIRE	
7.	802-617C	HHFS 1/4-20 X 1 1/2 GR 5	
8.	814-157C	2 X 13 PRESS WHEEL ASSEMBLY	Includes 3,4,6 & 7.
9.	199-042D	UNIVERSAL PW ARM MACH 2&3X13	
10.	817-084C	PARALLEL ARM PIVOT BUSHING	
11.	198-137D	PRESS WHEEL PIVOT TUBE	
12.	805-154C	PIN CLEVIS 3/8 X 2 1/8 USABLE	
13.	807-106C	SPRING .540 O.D.X 1 1/4 X.054W	
14.	817-347C	OPENER TRUNION	
15.	802-421C	HFS 1/2-13X3 3/4 GR5 SPTHD	
16.	803-169C	NUT HEX FLG. LOCK 1/2-13 PLT.	
17.	817-328C	T-HANDLE ASSEMBLY	
18.	805-186C	PIN ROLL 5/32 X 5/8 PLT	
19.	122-202S	PW ADJUSTMENT TRUNNION ASSY	Includes 12,13,14,17 & 18.

Legend: ● = 1st revision; ● = 2nd revision; ● = 3rd revision; ● = use up existing stock; ⊗ = not interchangeable; ⊗ ① ● = for example: revision 2 is not interchangeable w/revision 1

3" x 13" Single Press Wheel

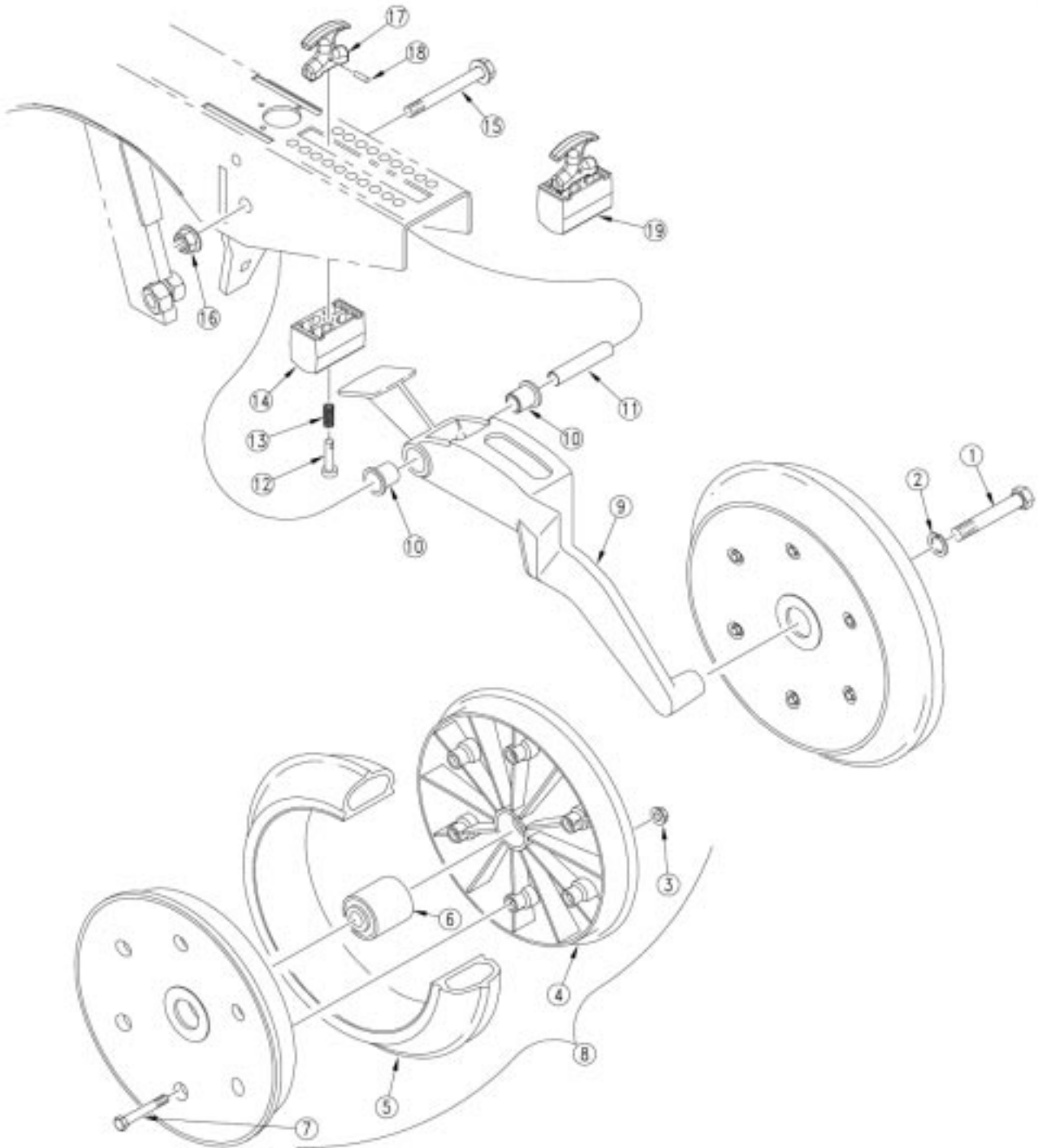

3" x 13" Single Press Wheel

Ref.	Part No.	Part Description	Comments
1.	802-058C	HHCS 5/8-11X2 1/2 GR5	
2.	804-022C	WASHER LOCK SPRING 5/8 PLT	
3.	803-088C	NUT HEX LOCK 1/4-20 FLG	
4.	817-297C	3 X 13 PRESS WHEEL RIM HALF	
5.	814-160C	3 X 13 PRESS WHEEL TIRE	
6.	822-170C	BEARING PRESS WHEEL ASSEMBLY	
7.	802-618C	HHFS 1/4-20 X 2 GR 5	
8.	814-158C	3 X 13 PRESS WHEEL ASSEMBLY	Includes 3,4,5 & 7
9.	199-042D	UNIVERSAL PW ARM MACH 2&3X13	
10.	817-084C	PARALLEL ARM PIVOT BUSHING	
11.	198-137D	PRESS WHEEL PIVOT TUBE	
12.	805-154C	PIN CLEVIS 3/8 X 2 1/8 USABLE	
13.	807-106C	SPRING .540 O.D.X 1 1/4 X.054W	
14.	817-347C	OPENER TRUNION	
15.	802-421C	HFS 1/2-13X3 3/4 GR5 SPTHD	
16.	803-169C	NUT HEX FLG. LOCK 1/2-13 PLT.	
17.	817-328C	T-HANDLE ASSEMBLY	
18.	805-186C	PIN ROLL 5/32 X 5/8 PLT	
19.	122-202S	PW ADJUSTMENT TRUNNION ASSY	Includes 12,13,14,17 & 18.

Legend: ● = 1st revision; ● = 2nd revision; ● = 3rd revision; ● = use up existing stock; ⊗ = not interchangeable; ⊗ ① ● = for example: revision 2 is not interchangeable w/revision 1

1" x 12" Double "V" Press Wheel

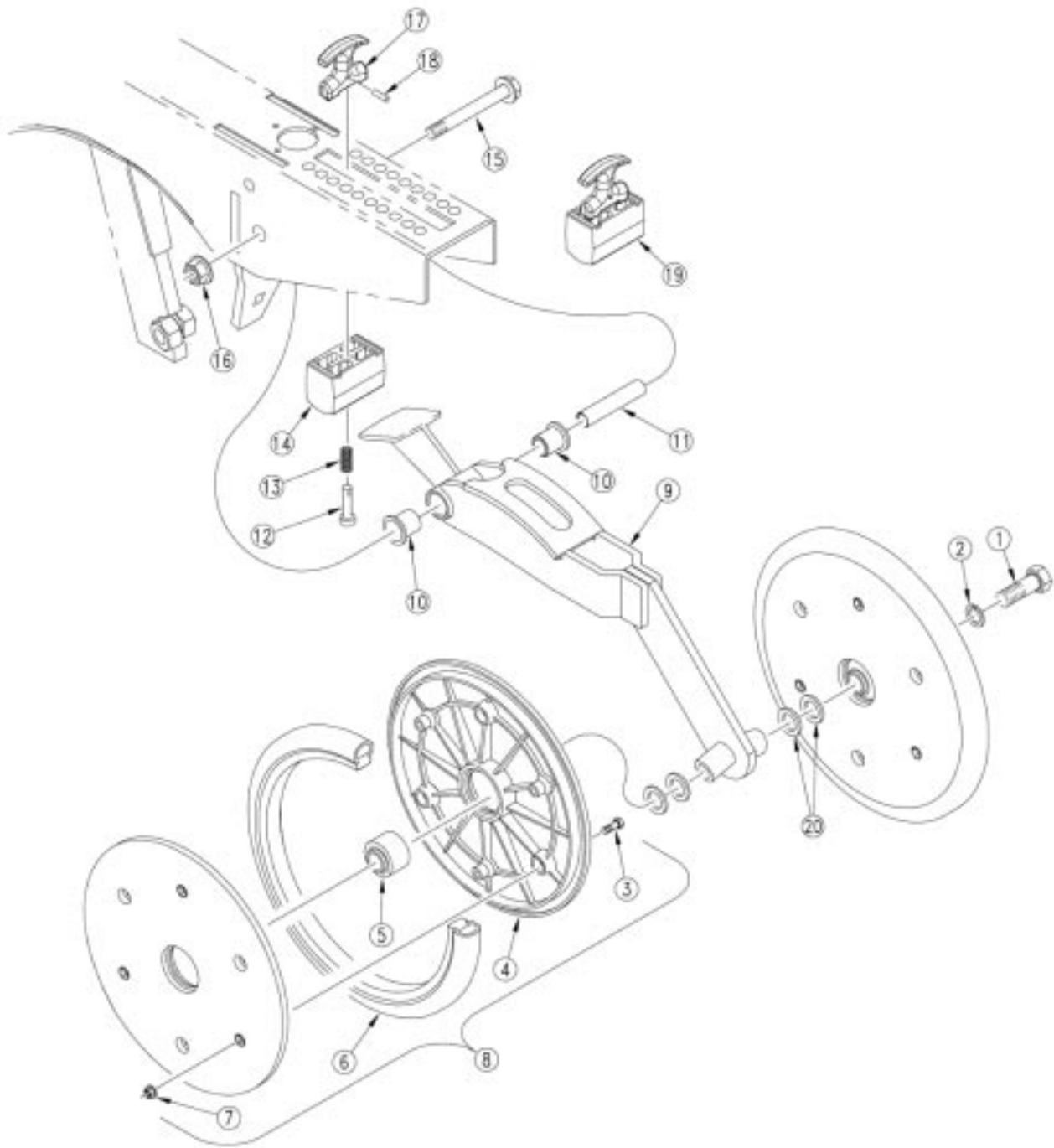

1" x 12" Double "V" Press Wheel

Ref.	Part No.	Part Description	Comments
1.	802-059C	HHCS 5/8-11X3 GR5	
2.	804-022C	WASHER LOCK SPRING 5/8 PLT	
3.	802-005C	HHCS 1/4-20X1 GR5	
4.	817-330C	1 X 12 PRESS WHEEL RIM HALF	
5.	822-170C	BEARING PRESS WHEEL ASSEMBLY	
6.	814-034C	TIRE RUBBER 1 X 12	
7.	803-088C	NUT HEX LOCK 1/4-20 FLG	
8.	814-174C	1 X 12 PRESS WHL ASSY-5203BRG	Includes 3,4,6 & 7
9.	199-022H	98 1X12 PRESS WHEEL WELDMENT	
10.	817-084C	PARALLEL ARM PIVOT BUSHING	
11.	198-137D	PRESS WHEEL PIVOT TUBE	
12.	805-154C	PIN CLEVIS 3/8 X 2 1/8 USABLE	
13.	807-106C	SPRING .540 O.D.X 1 1/4 X.054W	
14.	817-347C	OPENER TRUNION	
15.	802-421C	HFS 1/2-13X3 3/4 GR5 SPTHD	
16.	803-169C	NUT HEX FLG. LOCK 1/2-13 PLT.	
17.	817-328C	T-HANDLE ASSEMBLY	
18.	805-186C	PIN ROLL 5/32 X 5/8 PLT	
19.	122-202S	PW ADJUSTMENT TRUNNION ASSY	Includes 12,13,14,17 & 18.
20.	405-031D	1/4 PW SPACER 5/8 DIA	

Legend: ● = 1st revision; ● = 2nd revision; ● = 3rd revision; ● = use up existing stock; ⊗ = not interchangeable; ⊗ ① ● = for example: revision 2 is not interchangeable w/revision 1

1" x 12" Double "V" Press Wheel Short

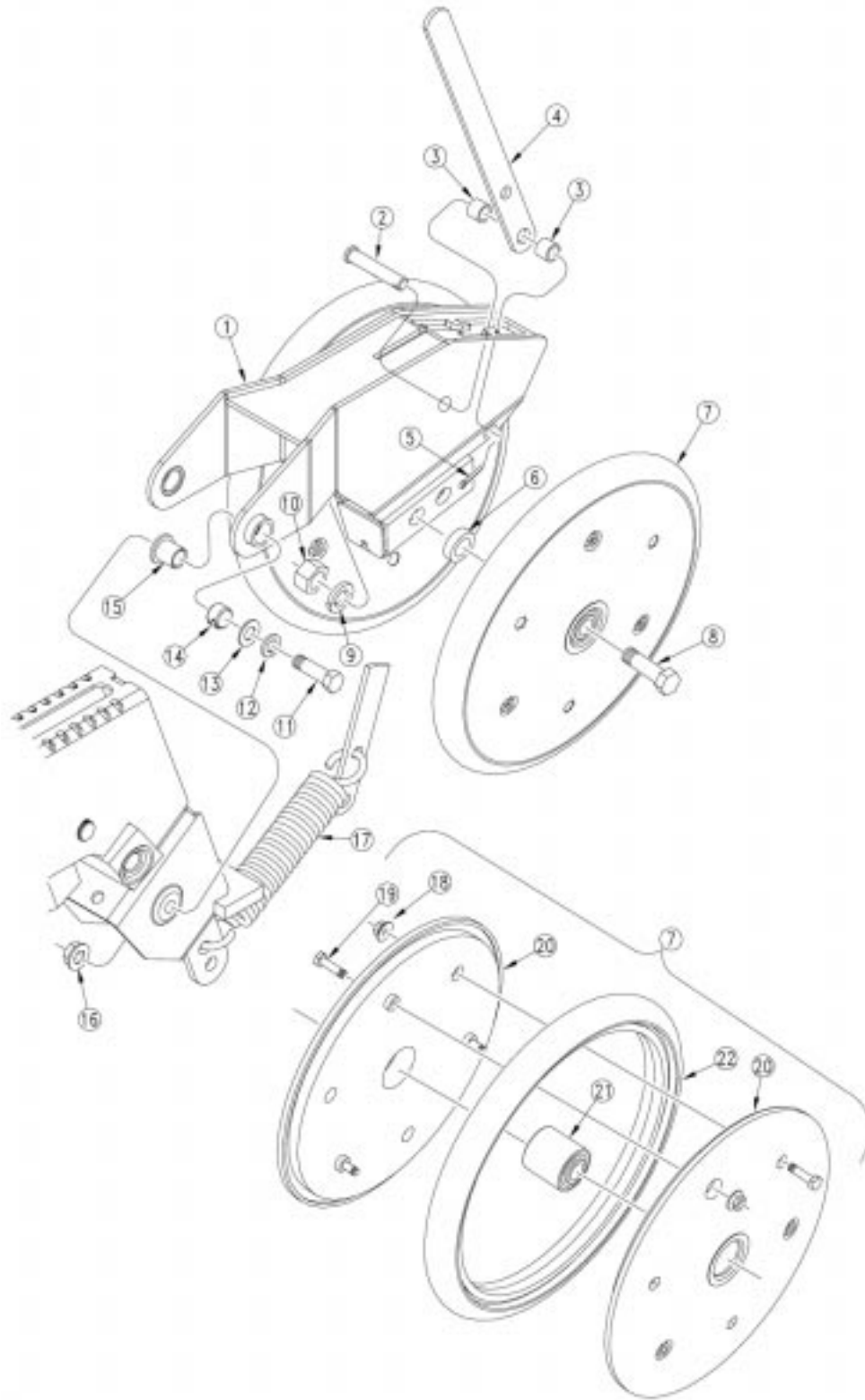

1" x 12" Double "V" Press Wheel Short

Ref.	Part No.	Part Description	Comments
1.	199-025H	SHORT 1X12 SING OPNR PW MOUNT	
2.	805-304C	PIN CLEVIS 7/16 X 2 25/64 USBL	
3.	199-050D	LONG 1X12 PW HANDLE SPACER TB	
4.	199-011D	PW SPRING HANDLE	
5.	805-067C	PIN COTTER 1/8 X 3/4	
6.	199-036D	1X12 PW 1/2 SPACER	
7.	814-174C	1 X 12 PRESS WHL ASSY-5203BRG	Includes 18,19,20 & 22
8.	802-160C	HHCS 5/8-11X3 1/4 GR5	
9.	804-022C	WASHER LOCK SPRING 5/8 PLT	
10.	803-021C	NUT HEX 5/8-11 PLT	
11.	802-029C	HHCS 7/16-14X1 1/2 GR5	
12.	804-014C	WASHER LOCK 7/16 PLT	
13.	804-041C	WASHER FLAT 7/16 SAE PLT	
14.	890-598C	BUSHING 3/4OD X 5/8ID X 1/2 LG	
15.	890-524C	20 SER PW ARM PIVOT SPACER TB	
16.	803-229C	NUT HEX FLANGE LOC 7/16-14 PLT	
17.	807-088C	SPRING EXT 1 5/8 OD X 8.2	
18.	803-088C	NUT HEX LOCK 1/4-20 FLG	
19.	802-005C	HHCS 1/4-20X1 GR5	
20.	817-330C	1 X 12 PRESS WHEEL RIM HALF	
21.	822-170C	BEARING PRESS WHEEL ASSEMBLY	
22.	814-034C	TIRE RUBBER 1 X 12	

Legend: ● = 1st revision; ● = 2nd revision; ● = 3rd revision; ● = use up existing stock; ⊗ = not interchangeable; ⊗ ① ● = for example: revision 2 is not interchangeable w/revision 1

1" x 12" Double "V" Press Wheel Long

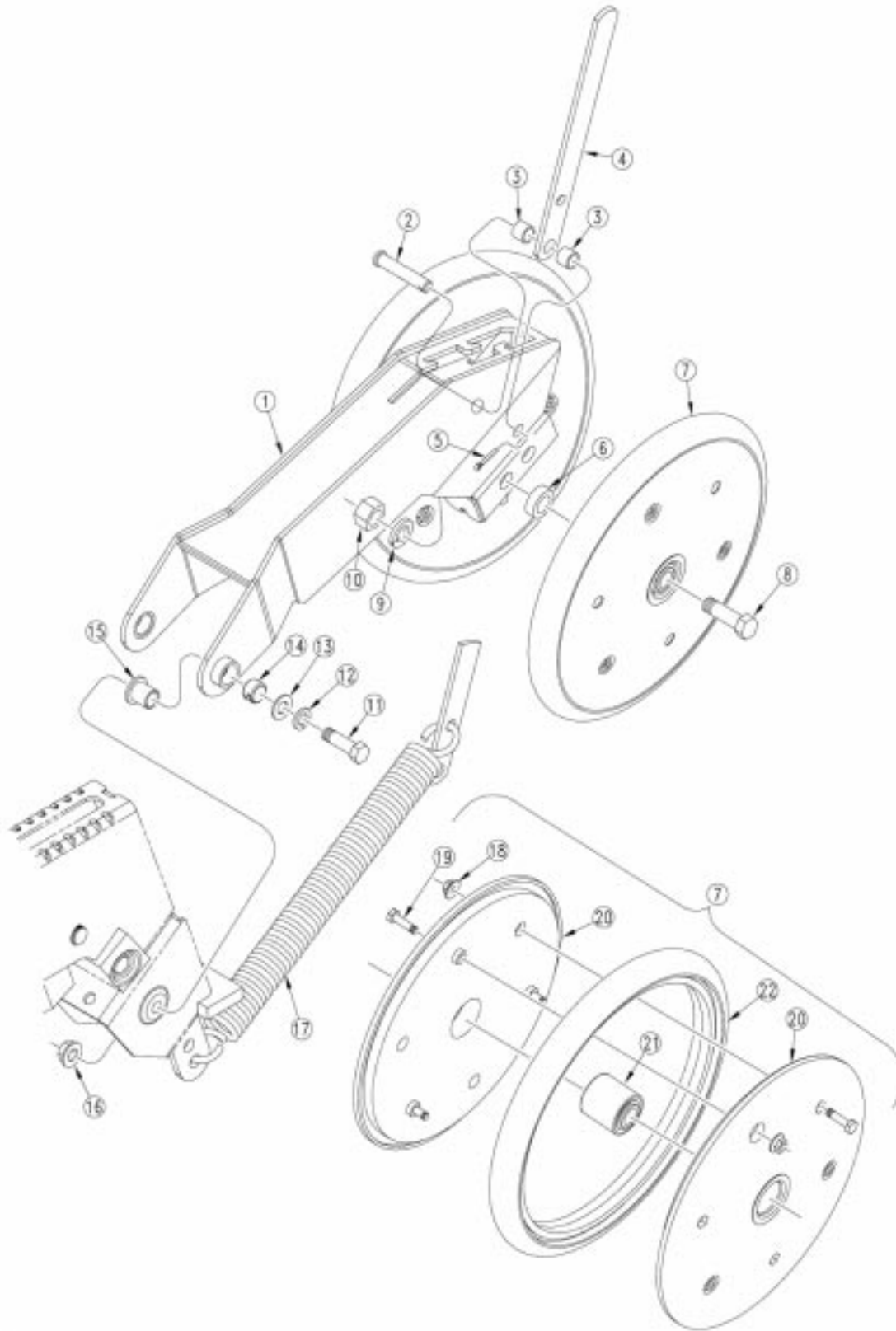

18193

1" x 12" Double "V" Press Wheel Long

Ref.	Part No.	Part Description	Comments
1.	199-024H	LONG 1X12 SING OPENER PW MOUNT	
2.	805-295C	PIN CLEVIS 7/16 X 2 9/64 USABL	
3.	199-050D	LONG 1X12 PW HANDLE SPACER TB	
4.	199-011D	PW SPRING HANDLE	
5.	805-067C	PIN COTTER 1/8 X 3/4	
6.	199-036D	1X12 PW 1/2 SPACER	
7.	814-174C	1 X 12 PRESS WHL ASSY-5203BRG	Includes 18,19,20 & 22
8.	802-160C	HHCS 5/8-11X3 1/4 GR5	
9.	804-022C	WASHER LOCK SPRING 5/8 PLT	
10.	803-021C	NUT HEX 5/8-11 PLT	
11.	802-029C	HHCS 7/16-14X1 1/2 GR5	
12.	804-014C	WASHER LOCK 7/16 PLT	
13.	804-041C	WASHER FLAT 7/16 SAE PLT	
14.	890-598C	BUSHING 3/4OD X 5/8ID X 1/2 LG	
15.	890-524C	20 SER PW ARM PIVOT SPACER TB	
16.	803-229C	NUT HEX FLANGE LOC 7/16-14 PLT	
17.	807-184C	SPRING EXT 1.5OD X .25 X 11.25	
18.	803-088C	NUT HEX LOCK 1/4-20 FLG	
19.	802-005C	HHCS 1/4-20X1 GR5	
20.	817-330C	1 X 12 PRESS WHEEL RIM HALF	
21.	822-170C	BEARING PRESS WHEEL ASSEMBLY	
22.	814-034C	TIRE RUBBER 1 X 12	

Legend: ● = 1st revision; ● = 2nd revision; ● = 3rd revision; ● = use up existing stock; ⊗ = not interchangeable; ⊗ ① ● = for example: revision 2 is not interchangeable w/revision 1

1" x 10" Double "V" Press Wheel (10/1/2000+)

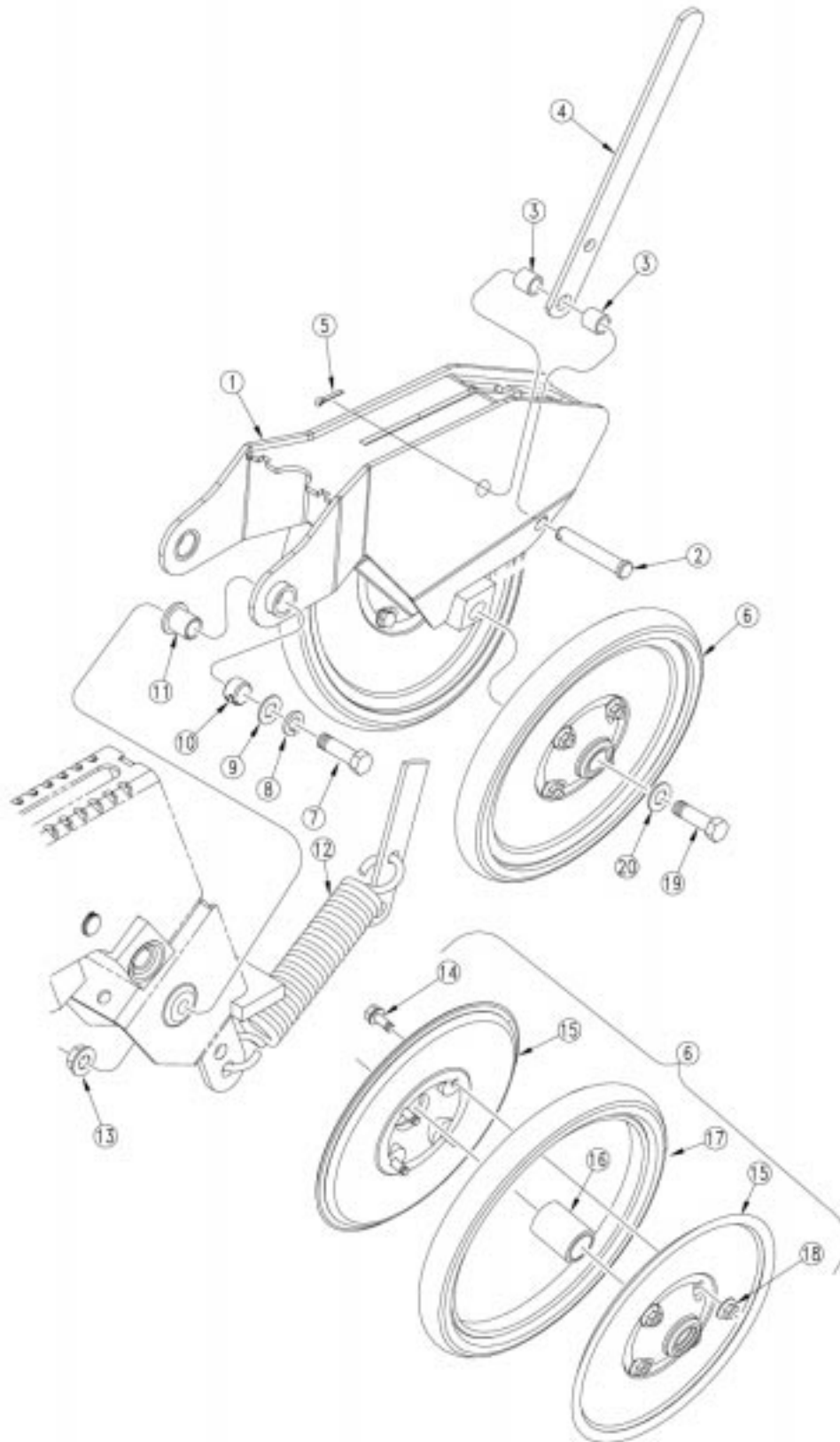

19901

1" x 10" Double "V" Press Wheel (10/1/2000+)

Ref.	Part No.	Part Description	Comments
1.	199-027H	1X10 SING PRESS WHEEL MOUNT	
2.	805-166C	PIN CLEVIS 7/16 X 3 PLT	
3.	199-015D	PW HANDLE SPACER TUBE	
4.	199-011D	PW SPRING HANDLE	
5.	805-067C	PIN COTTER 1/8 X 3/4	
6.	814-194C	1X10 PRESS WHEEL ASSEMBLY	
7.	802-029C	HHCS 7/16-14X1 1/2 GR5	
8.	804-014C	WASHER LOCK 7/16 PLT	
9.	804-041C	WASHER FLAT 7/16 SAE PLT	
10.	890-598C	BUSHING 3/4OD X 5/8ID X 1/2 LG	
11.	890-524C	20 SER PW ARM PIVOT SPACER TB	
12.	807-088C	SPRING EXT 1 5/8 OD X 8.2	
13.	803-229C	NUT HEX FLANGE LOC 7/16-14 PLT	
14.	802-196C	HFSS 1/4-20X5/8 GR5	
15.	814-192C	1X10 PRESS WHEEL RIM HALF	
16.	822-170C	BEARING PRESS WHEEL ASSEMBLY	
17.	814-085C	1X10 PRESS WHEEL TIRE	
18.	803-088C	NUT HEX LOCK 1/4-20 FLG	
19.	802-058C	HHCS 5/8-11X2 1/2 GR5	
20.	804-022C	WASHER LOCK SPRING 5/8 PLT	

Legend: ● = 1st revision; ● = 2nd revision; ● = 3rd revision; ● = use up existing stock; ⊗ = not interchangeable; ⊗ ① ● = for example: revision 2 is not interchangeable w/revision 1

1" x 10" Double "V" Press Wheel (9/30/2000-)

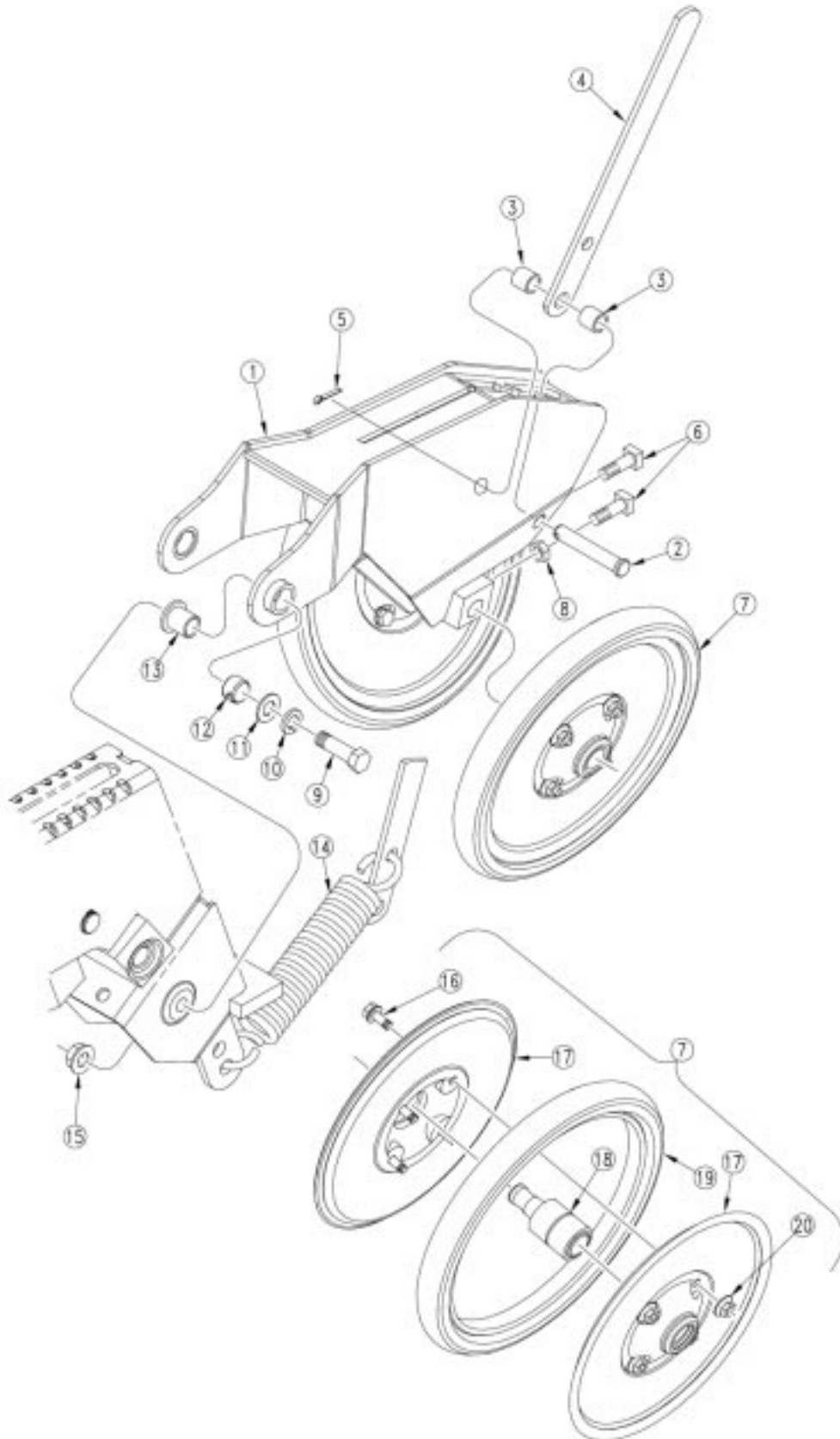

20045

1" x 10" Double "V" Press Wheel (9/30/2000-)

Ref.	Part No.	Part Description	Comments
1.	199-026H	1 X 10 SING OPENER PW MOUNT	
2.	805-304C	PIN CLEVIS 7/16 X 2 25/64 USBL	
3.	199-050D	LONG 1X12 PW HANDLE SPACER TB	
4.	199-011D	PW SPRING HANDLE	
5.	805-067C	PIN COTTER 1/8 X 3/4	
6.	801-007C	SCREW SET SQ HD 3/8-16X7/8 PLT	
7.	199-009S	1 X 10 PRESS WHEEL ASSY	Includes 16,17,19 & 20
8.	803-012C	NUT HEX JAM 3/8-16 PLT	
9.	802-029C	HHCS 7/16-14X1 1/2 GR5	
10.	804-014C	WASHER LOCK 7/16 PLT	
11.	804-041C	WASHER FLAT 7/16 SAE PLT	
12.	890-598C	BUSHING 3/4OD X 5/8ID X 1/2 LG	
13.	890-524C	20 SER PW ARM PIVOT SPACER TB	
14.	807-088C	SPRING EXT 1 5/8 OD X 8.2	
15.	803-229C	NUT HEX FLANGE LOC 7/16-14 PLT	
16.	802-196C	HFSS 1/4-20X5/8 GR5	
17.	814-084C	1X10 P.W. RIM HALF	
18.	822-023C	BEARING PW SINGLE ENDED	
19.	814-085C	1X10 PRESS WHEEL TIRE	
20.	803-088C	NUT HEX LOCK 1/4-20 FLG	

Legend: ● = 1st revision; ● = 2nd revision; ● = 3rd revision; ● = use up existing stock; ⊗ = not interchangeable; ⊗ ① ● = for example: revision 2 is not interchangeable w/revision 1

1 1/4" x 13 1/2" Double Press Wheel

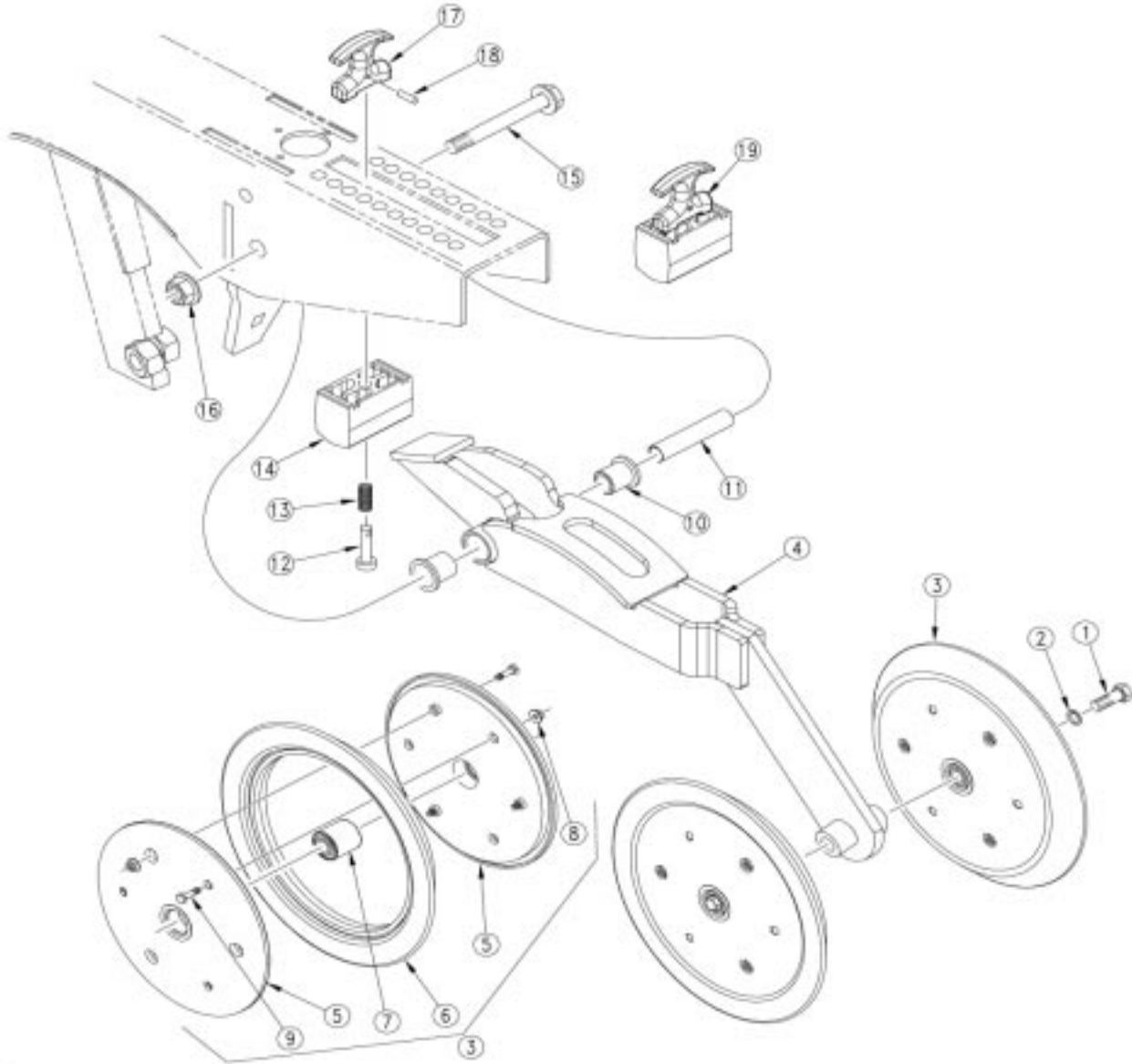

1 1/4" x 13 1/2" Double Press Wheel

Ref.	Part No.	Part Description	Comments
1.	802-058C	HHCS 5/8-11X2 1/2 GR5	
2.	804-022C	WASHER LOCK SPRING 5/8 PLT	
3.	814-238C	1.25 X 13.5 PRESS WHEEL ASSY	Includes items 5-9.
4.	⊗ 199-065H	DOUBLE PRESS WHEEL ARM WLD RH	(S/N 10801C+) For Front Openers
	⊗ 199-066H	DOUBLE PRESS WHEEL ARM WLD LH	(S/N 10801C+) For Rear Openers
	Ⓜ 199-038H	DOUBLE PRESS WHEEL ARM WLDMT	(S/N 10800C-)
5.	817-330C	1 X 12 PRESS WHEEL RIM HALF	
6.	814-244C	1.25 X 13.5 PRESS WHEEL TIRE	
7.	822-170C	BEARING PRESS WHEEL ASSEMBLY	
8.	803-088C	NUT HEX LOCK 1/4-20 FLG	
9.	802-005C	HHCS 1/4-20X1 GR5	
10.	817-084C	PARALLEL ARM PIVOT BUSHING	
11.	198-137D	PRESS WHEEL PIVOT TUBE	
12.	805-154C	PIN CLEVIS 3/8 X 2 1/8 USABLE	
13.	807-106C	SPRING .540 O.D.X 1 1/4 X.054W	
14.	817-347C	OPENER TRUNION	
15.	802-421C	HFS 1/2-13X3 3/4 GR5 SPTHD	
16.	803-169C	NUT HEX FLG. LOCK 1/2-13 PLT.	
17.	817-328C	T-HANDLE ASSEMBLY	
18.	805-186C	PIN ROLL 5/32 X 5/8 PLT	
19.	122-202S	PW ADJUSTMENT TRUNNION ASSY	Includes items 12-14, 17 & 18.

1 1/4" x 13" Double Press Wheel

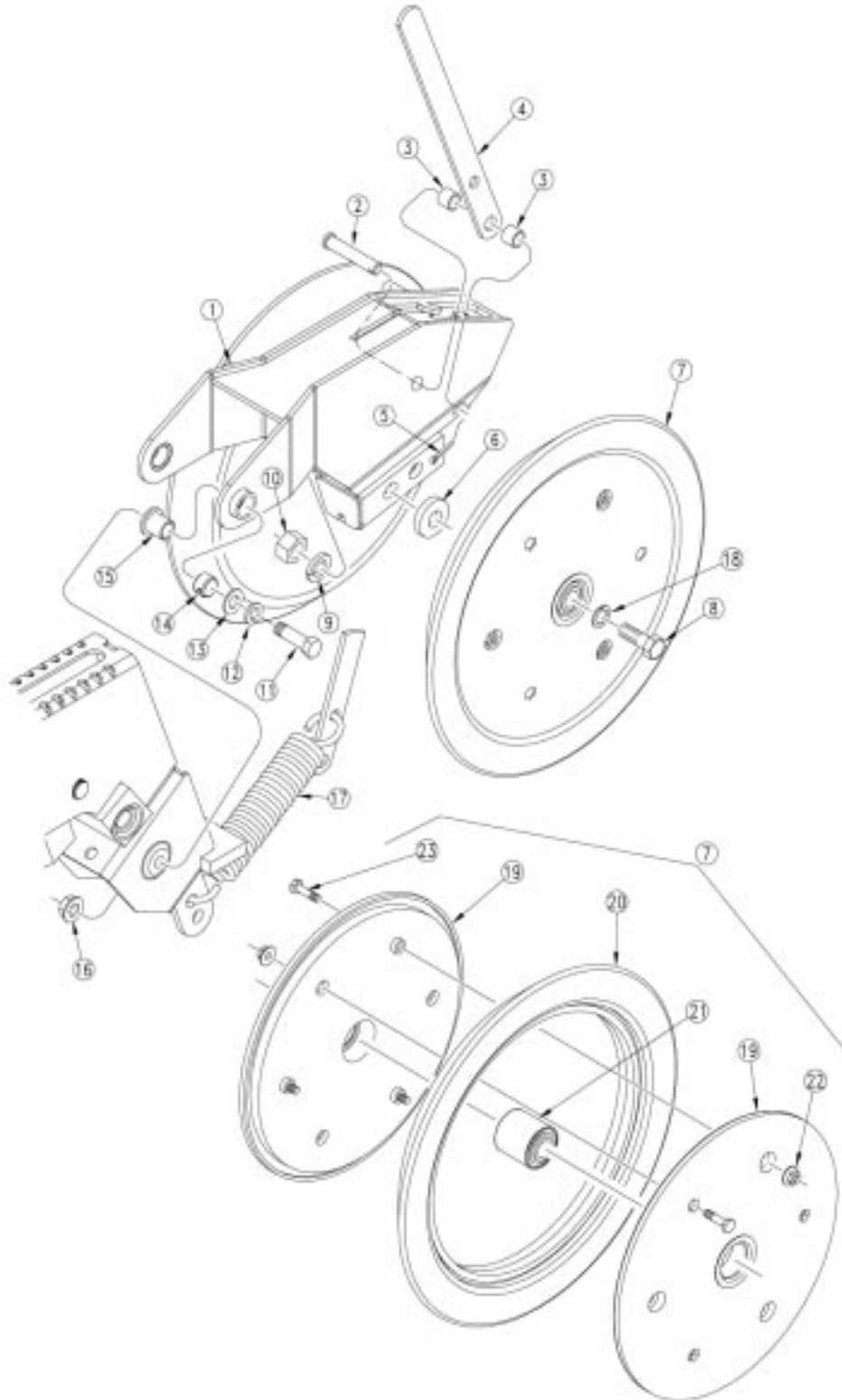

1 1/4" x 13" Double Press Wheel

Ref.	Part No.	Part Description	Comments
1.	199-025H	SHORT 1X12 SING OPNR PW MOUNT	
2.	805-304C	PIN CLEVIS 7/16 X 2 25/64 USBL	
3.	199-050D	LONG 1X12 PW HANDLE SPACER TB	
4.	199-011D	PW SPRING HANDLE	
5.	805-067C	PIN COTTER 1/8 X 3/4	
6.	405-031D	1/4 PW SPACER 5/8 DIA	
7.	814-238C	1.25 X 13.5 PRESS WHEEL ASSY	Includes items 19-23.
8.	802-059C	HHCS 5/8-11X3 GR5	
9.	804-022C	WASHER LOCK SPRING 5/8 PLT	
10.	803-021C	NUT HEX 5/8-11 PLT	
11.	802-029C	HHCS 7/16-14X1 1/2 GR5	
12.	804-014C	WASHER LOCK 7/16 PLT	
13.	804-041C	WASHER FLAT 7/16 SAE PLT	
14.	890-598C	BUSHING 3/4OD X 5/8ID X 1/2 LG	
15.	890-524C	20 SER PW ARM PIVOT SPACER TB	
16.	803-229C	NUT HEX FLANGE LOC 7/16-14 PLT	
17.	807-088C	SPRING EXT 1 5/8 OD X 8.2	
18.	804-022C	WASHER LOCK SPRING 5/8 PLT	
19.	817-330C	1 X 12 PRESS WHEEL RIM HALF	
20.	814-244C	1.25 X 13.5 PRESS WHEEL TIRE	
21.	822-170C	BEARING PRESS WHEEL ASSEMBLY	
22.	803-088C	NUT HEX LOCK 1/4-20 FLG	
23.	802-005C	HHCS 1/4-20X1 GR5	



Legend: ● = 1st revision; ● = 2nd revision; ● = 3rd revision; ● = use up existing stock; ⊗ = not interchangeable; ⊗ ① ● = for example: revision 2 is not interchangeable w/revision 1

2" x 12 1/2" Double Press Wheel

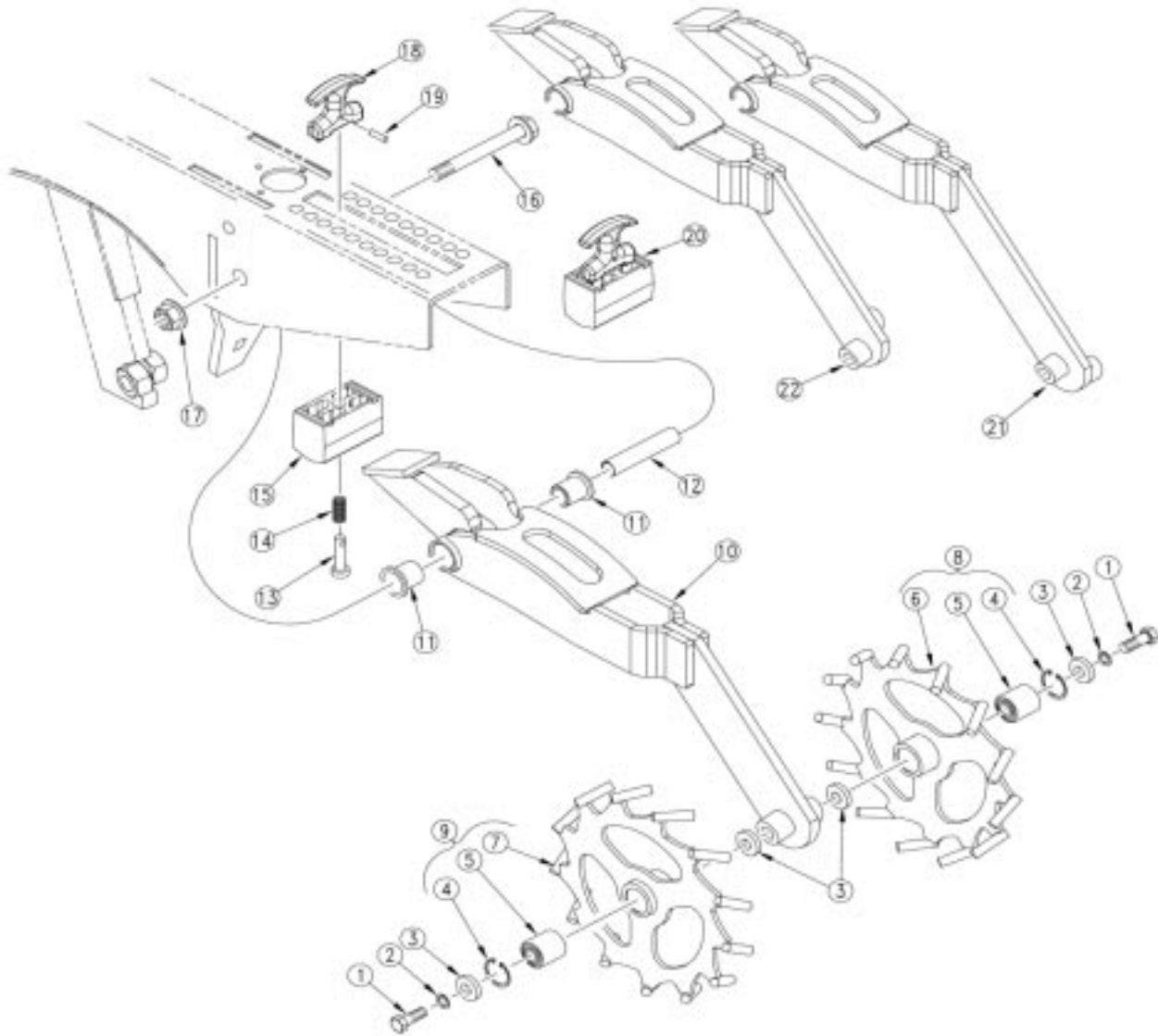

2" x 12 1/2" Double Press Wheel

Ref.	Part No.	Part Description	Comments
1.	802-059C	HHCS 5/8-11X3 GR5	
2.	804-022C	WASHER LOCK SPRING 5/8 PLT	
3.	405-031D	1/4 PW SPACER 5/8 DIA	
4.	800-054C	SNAP RING INT 40 MM	
5.	822-170C	BEARING PRESS WHEEL ASSEMBLY	
6.	199-040H	2X12.5 CLOSING WHEEL WLDMT RH	
7.	199-039H	2X12.5 CLOSING WHEEL WLDMT LH	
8.	199-042S	2X12.5 CLOSING WHEEL ASSY RH	Must use with item #10.
9.	199-041S	2X12.5 CLOSING WHEEL ASSY LH	Must use with item #10.
10.	⊗ 199-065H	DOUBLE PRESS WHEEL ARM WLD RH	(S/N 10801C+) For Front Openers)
	⊗ 199-066H	DOUBLE PRESS WHEEL ARM WLD LH	(S/N 10801C+ For Rear Openers)
	Ⓜ 199-038H	DOUBLE PRESS WHEEL ARM WLDMT	(S/N 10800C-)
11.	817-084C	PARALLEL ARM PIVOT BUSHING	
12.	198-137D	PRESS WHEEL PIVOT TUBE	
13.	805-154C	PIN CLEVIS 3/8 X 2 1/8 USABLE	
14.	807-106C	SPRING .540 O.D.X 1 1/4 X.054W	
15.	817-347C	OPENER TRUNION	
16.	802-421C	HFS 1/2-13X3 3/4 GR5 SPTH	
17.	803-169C	NUT HEX FLG. LOCK 1/2-13 PLT.	
18.	817-328C	T-HANDLE ASSEMBLY	
19.	805-186C	PIN ROLL 5/32 X 5/8 PLT	
20.	122-202S	PW ADJUSTMENT TRUNNION ASSY	

2" x 12 1/2" Double Press Wheel

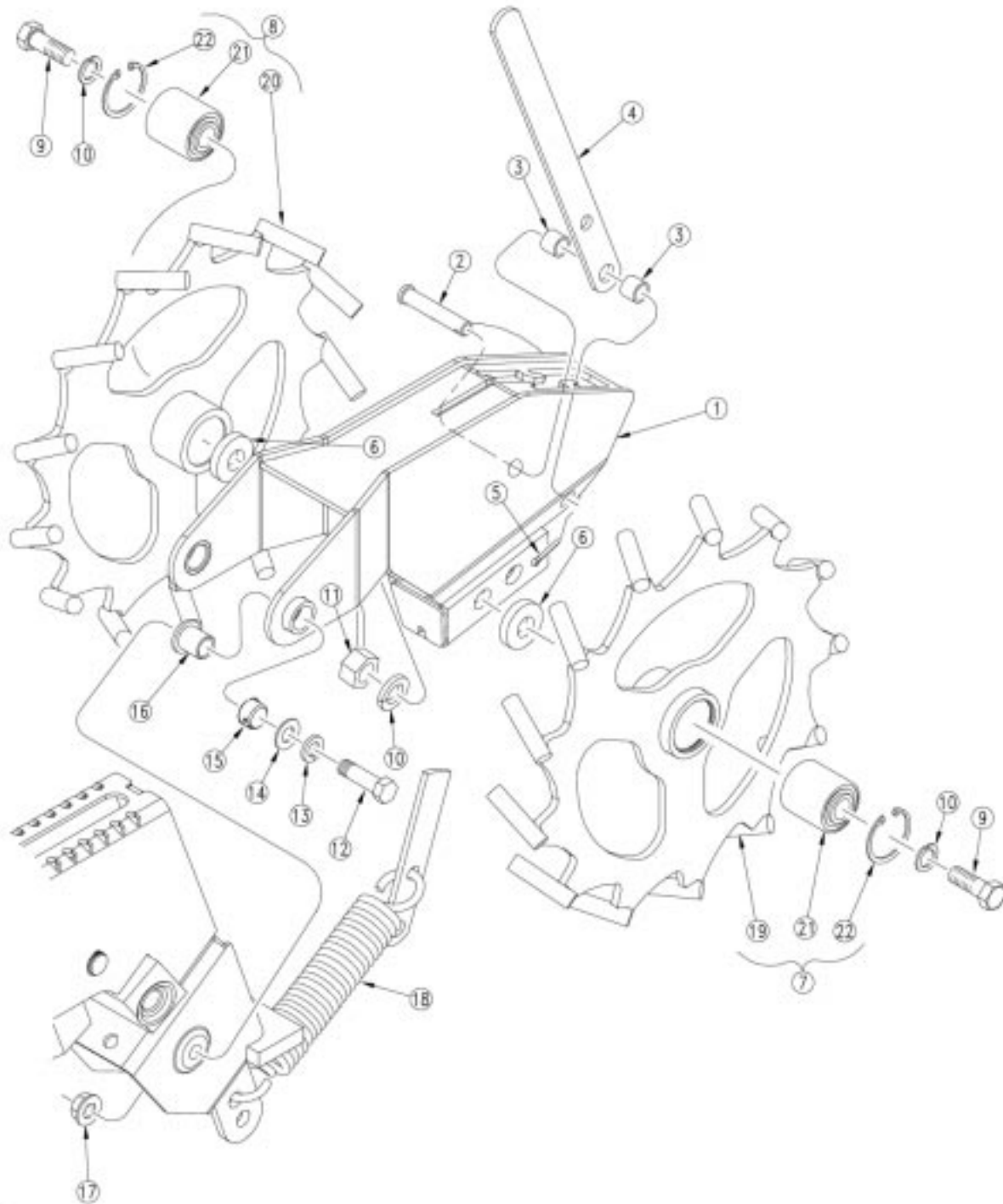

2" x 12 1/2" Double Press Wheel

Ref.	Part No.	Part Description	Comments
1.	199-025H	SHORT 1X12 SING OPNR PW MOUNT	
2.	805-304C	PIN CLEVIS 7/16 X 2 25/64 USBL	
3.	199-050D	LONG 1X12 PW HANDLE SPACER TB	
4.	199-011D	PW SPRING HANDLE	
5.	805-063C	PIN COTTER 3/32 X 1 LONG	
6.	405-031D	1/4 PW SPACER 5/8 DIA	
7.	199-042S	2X12.5 CLOSING WHEEL ASSY RH	Includes items 19-22.
8.	199-041S	2X12.5 CLOSING WHEEL ASSY LH	Includes items 20-22.
9.	802-059C	HHCS 5/8-11X3 GR55	
10.	804-022C	WASHER LOCK SPRING 5/8 PLT	
11.	803-021C	NUT HEX 5/8-11 PLT	
12.	802-029C	HHCS 7/16-14X1 1/2 GR5	
13.	804-014C	WASHER LOCK 7/16 PLT	
14.	804-041C	WASHER FLAT 7/16 SAE PLT	
15.	890-598C	BUSHING 3/4OD X 5/8ID X 1/2 LG	
16.	890-524C	20 SER PW ARM PIVOT SPACER TB	
17.	803-229C	NUT HEX FLANGE LOC 7/16-14 PLT	
18.	807-088C	SPRING EXT 1 5/8 OD X 8.2	
19.	199-040H	2X12.5 CLOSING WHEEL WLDMT RH	
20.	199-039H	2X12.5 CLOSING WHEEL WLDMT LH	
21.	822-170C	BEARING PRESS WHEEL ASSEMBLY	
22.	800-054C	SNAP RING INT 40 MM	

Legend: ● = 1st revision; ● = 2nd revision; ● = 3rd revision; ● = use up existing stock; ⊗ = not interchangeable; ⊗ ① ● = for example: revision 2 is not interchangeable w/revision 1

Decal Placement

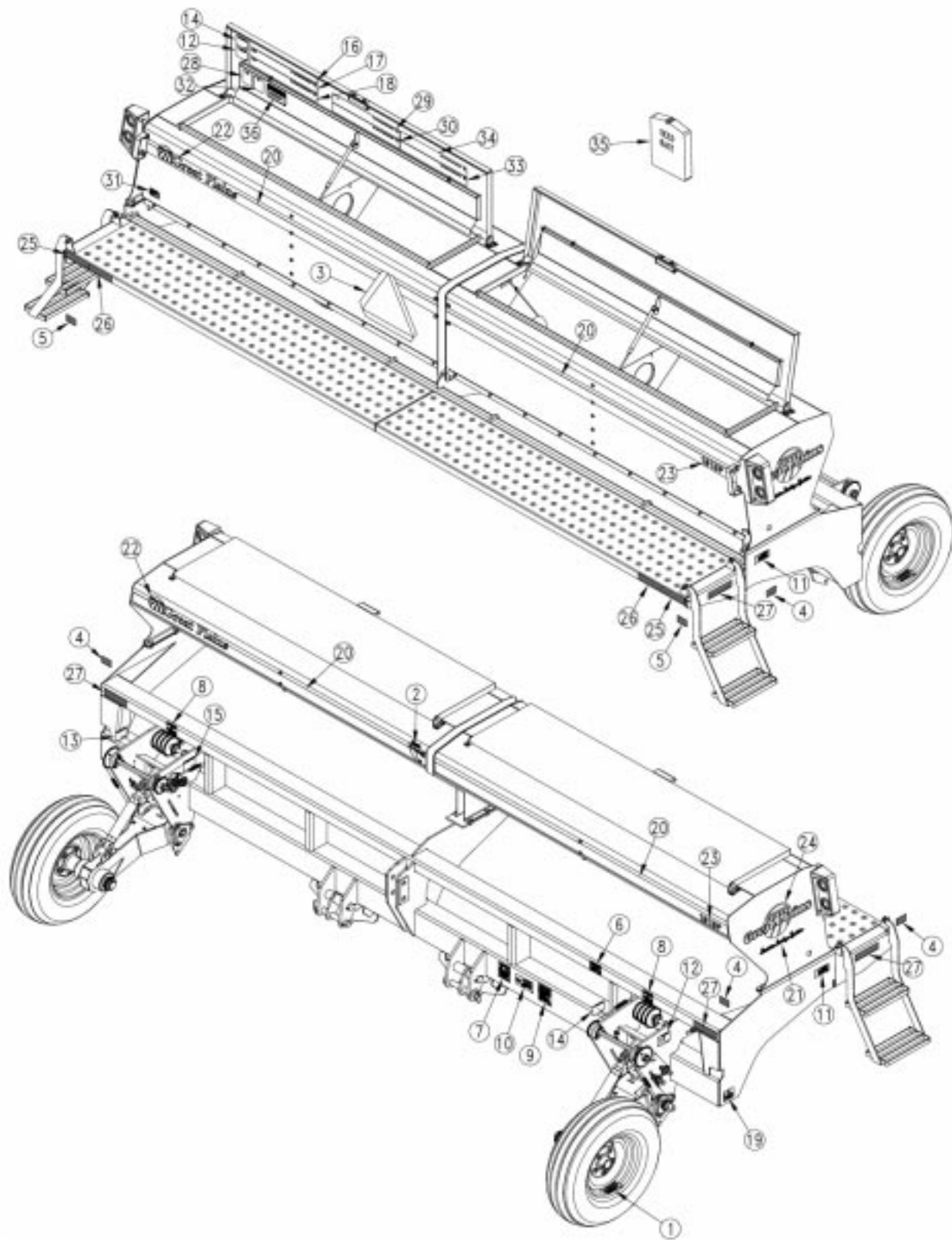

Decal Placement

Ref.	Part No.	Part Description	Comments
1.	818-751C	DECAL CAUTION TIRE 32 PSI	
2.	838-237C	DECAL SEED LEVEL LH	
3.	818-003C	DECAL SLOW MOVING VEHICLE	
4.	818-229C	DECAL AMBER REFLECTOR	Model year 2000-
5.	818-230C	DECAL RED REFLECTOR	Model year 2000-
6.	818-337C	DECAL WARNING 20 MPH TRANS SML	
7.	818-339C	DECAL WARNING HIGH PRESSUR SML	
8.	818-398C	DECAL CAUTION TIRES NOT A STEP	
9.	818-587C	DECAL CAUTION OPERATIONAL MACH	
10.	818-590C	DECAL DANGER CRUSH TRCTR & 3PT	
11.	838-102C	DECAL DANGER FALLING HAZZARD	
12.	838-122C	DECAL 15&20-P RANGE SPKTS LH	
13.	838-123C	DECAL 15&20-P RANGE SPKTS RH	
14.	838-124C	DECAL 15&20-P TRANSM SPKTS LH	
15.	838-125C	DECAL 15&20-P TRANSM SPKTS RH	
16.	838-130C	DECAL SEEDRT-15P WHEAT LOW RAT	
17.	838-131C	DECAL SEEDRT-15P WHEAT HIGH RA	
18.	838-132C	DECAL SEEDRT-15P SOYBEAN	
19.	838-153C	DECAL -P GROUND AND TUBE DIST	
20.	838-160C	DECAL 3 COLOR STRIPE 2.50 WIDE	
21.	838-157C	DECAL SCRIPT PREC SEED SYSTEM	
22.	838-161C	DECAL LOGO&GP F/STRIPE 4 X 24	
23.	838-126C	DECAL 1510 P	
	838-127C	DECAL 1520 P	
24.	838-228C	DECAL GREAT PLAINS ON LOGO SML	
25.	838-266C	DECAL REFLECTOR RED 1 1/2X9	Model year 2001+.
26.	838-267C	DECAL REFLECTR DAYTIME 1 1/2X9	Model year 2001+.
27.	838-265C	DECAL REFLECTOR AMBER 1 1/2X9	Model year 2001+.
28.	838-273C	DECAL TALC LUBRICANT IMPORTANT	
29.	838-134C	DECAL SEEDRT-15P COTTON	
30.	838-139C	DECAL SEEDRT-15P CORN	
31.	838-400C	DECAL NOTICE SEED TUBES	
32.	838-352C	DECAL MILO W/GRAPHITE INSTR	
33.	838-135C	DECAL SEEDRT-15P RICE 7 1/2	S/N 10619C- (Wheel # 403-107V)
34.	838-452C	DECAL SEEDRT-15P RICE-MED RATE	S/N 10620C+(Wheel #403-089D)
35.	817-516C	MANUAL PAK 1" W/ GASKET	
36.	838-617C	DECAL NOTICE 4-MIL DISC BLADES	

Legend: ● = 1st revision; ● = 2nd revision; ● = 3rd revision; ● = use up existing stock; ⊗ = not interchangeable; ⊗ ① ● = for example: revision 2 is not interchangeable w/revision 1

Flat Fold Marker

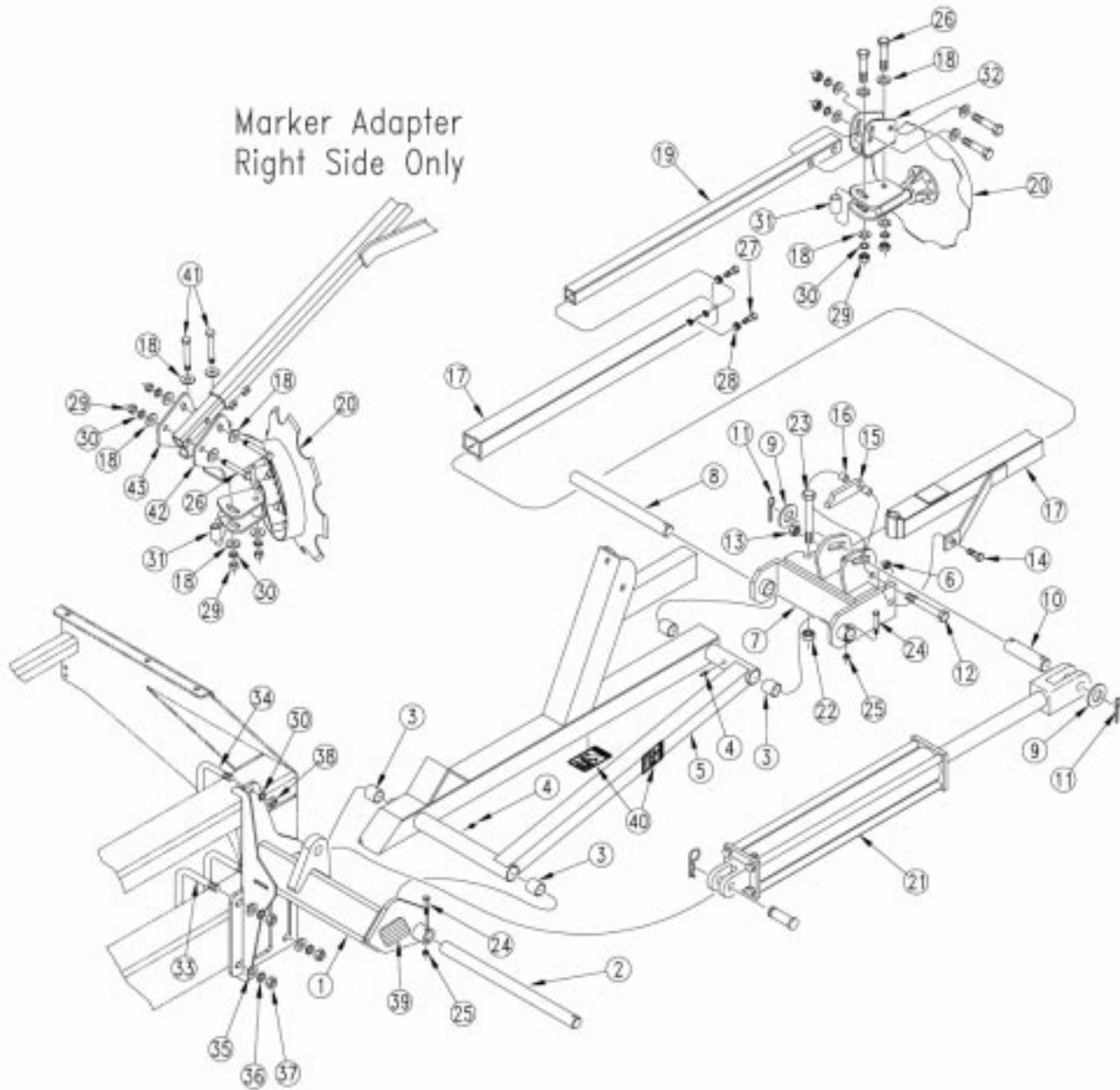

Flat Fold Marker

Ref.	Part No.	Part Description	Comments
1.	113-690H	MARKER MOUNT RH	
	113-689H	MARKER MOUNT LH	Shown.
2.	113-312D	FIRST PIVOT SHAFT	
3.	890-005C	BUSHING CYL 1 1/4 X 1 X 1	
4.	800-001C	GREASE ZERK STRAIGHT 1/4-28	
5.	113-188H	RH FIRST SECTION	
	113-180H	LH FIRST SECTION	Shown.
6.	803-013C	NUT LOCK 3/8-16 PLT	
7.	113-467H	LIFT LUG CHANNEL R.H.	
	113-468H	LIFT LUG CHANNEL L.H.	Shown.
8.	113-313D	SECOND PIVOT SHAFT	
9.	804-029C	WASHER FLAT 1 SAE	
10.	113-248D	PIN 1 OD X 4.34 USABLE	
11.	805-058C	PIN COTTER 3/16 X 2	
12.	802-249C	HHCS 1/2-13X4 1/2 GR5 SPTH	
13.	803-019C	NUT LOCK 1/2-13 PLT	
14.	802-253C	HHCS 3/8-16X1 3/4 GR2	
15.	113-324D	CYLINDER STOP	
16.	113-325D	STOP BUSHING	
17.	113-191H	2 SECTION MARKER BREAKAWAY	
18.	804-017C	WASHER FLAT 1/2 USS PLT	
19.	113-351D	MARKER TUBE 42 LG	
20.	113-563S	MARKER DISC & HUB ASSEMBLY	
21.	810-205C	CYL 2X20X1.12 ROD (TIE) 1 PIN	
22.	803-024C	NUT LOCK 5/8-11 PLT	
23.	802-254C	HHCS 5/8-11X5 1/2 GR5	
24.	802-115C	HHCS 5/16-18X2 GR5	
25.	803-011C	NUT LOCK 5/16-18 PLT	
26.	802-099C	HHCS 1/2-13X3 1/4 GR5	
27.	801-054C	SCREW SET SQ HD. 1/2-13X1 GR5	
28.	803-036C	NUT HEX JAM 1/2-13 PLT	
29.	803-020C	NUT HEX 1/2-13 PLT	
30.	804-015C	WASHER LOCK SPRING 1/2 PLT	
31.	113-491D	ADJUST MOUNT SPACER TUBE	
32.	113-503H	MARKER DISK ADJUST MOUNT	
33.	806-053C	U-BOLT 5/8-11 X 7 1/32 X 6 1/2	
34.	806-122C	U-BOLT 1/2-13 X 3 1/32 X 6	
35.	804-021C	WASHER FLAT 5/8 SAE PLT	
36.	804-022C	WASHER LOCK SPRING 5/8 PLT	
37.	803-021C	NUT HEX 5/8-11 PLT	
38.	803-020C	NUT HEX 1/2-13 PLT	
39.	818-229C	DECAL AMBER REFLECTOR	
40.	818-682C	DECAL WARNING PINCH/CRUSH MRKR	
41.	802-041C	HHCS 1/2-13X3 1/2 GR5	Marker adapter for right side.
42.	113-666D	MARKER REVERSING ADAPT PLATE 1	Marker adapter for right side.
43.	113-667D	MARKER REVERSING ADAPT PLATE 2	Marker adapter for right side.



Legend: ● = 1st revision; ● = 2nd revision; ● = 3rd revision; ● = use up existing stock; ⊗ = not interchangeable; ⊗ ① ● = for example: revision 2 is not interchangeable w/revision 1

Marker Disk And Hub (113-563S)

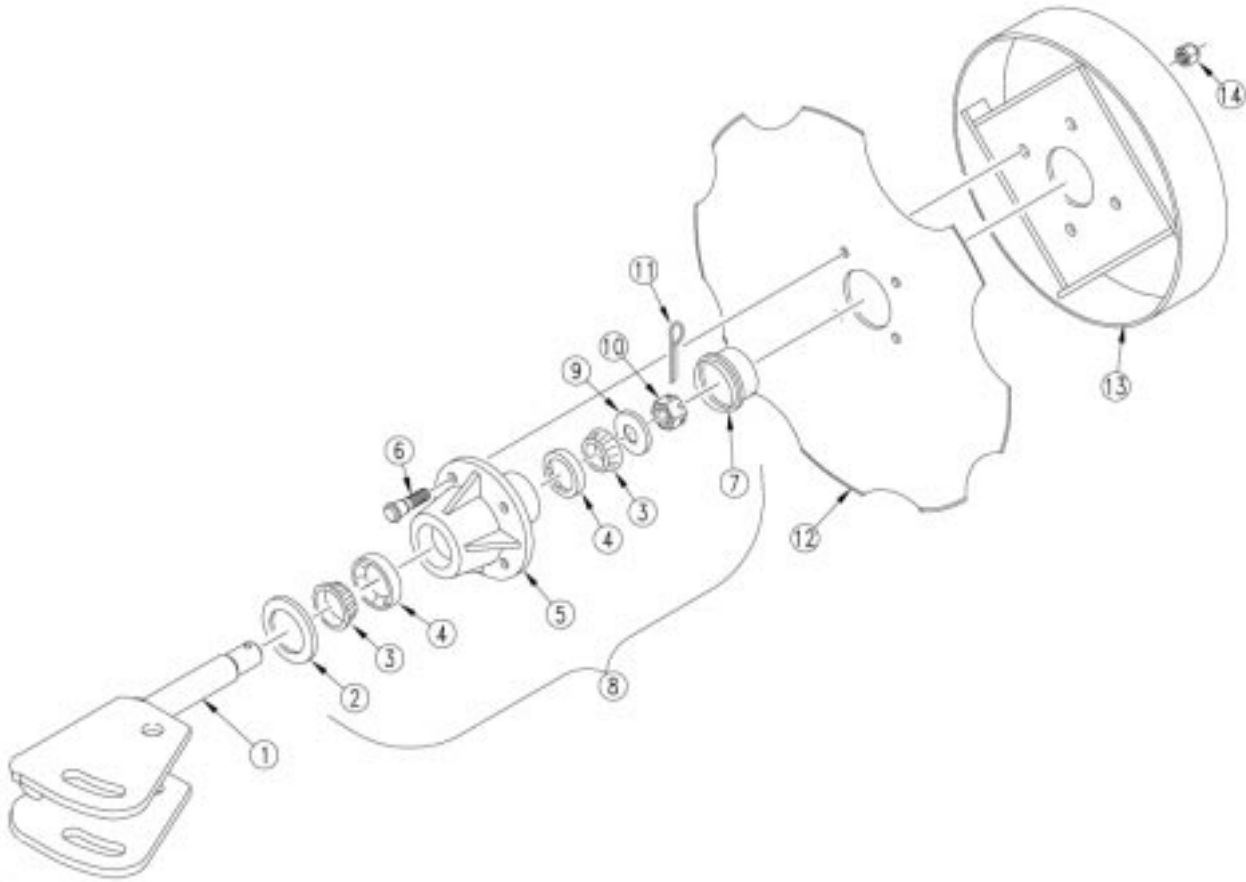

Marker Disk And Hub (113-563S)

Ref.	Part No.	Part Description	Comments
1.	113-562H	1 SPINDLE MARKER WELDMENT	
2.	816-014C	TINE GAUGE WHEEL HUB SEAL	
3.	822-030C	BEARING CONE L44643	
4.	822-080C	BEARING CUP L44610	
5.	1-100-02-00	RELIABLE HUB 4 BOLT	
6.	B0-47	NEILSON STUD 1/2-20UNFX1 13/16	
7.	890-614C	GREASE CAP #1505	
8.	815-001C	GW HUB	Includes 2,3,4,5 & 7
9.	804-025C	WASHER FLAT 3/4 SAE PLT	
10.	803-053C	NUT HEX SLOTTED 3/4-16	
11.	805-019C	PIN COTTER 5/32 X 1 PLT	
12.	820-094C	16 4-BOLT NOTCHED MARKER DISK	
13.	113-369H	DEPTH BAND 10 4-BOLT 4B.C.	
14.	803-159C	NUT LUG 1/2-20 X 60 DEG PLT	

Flat Fold Dual Marker Hydraulics

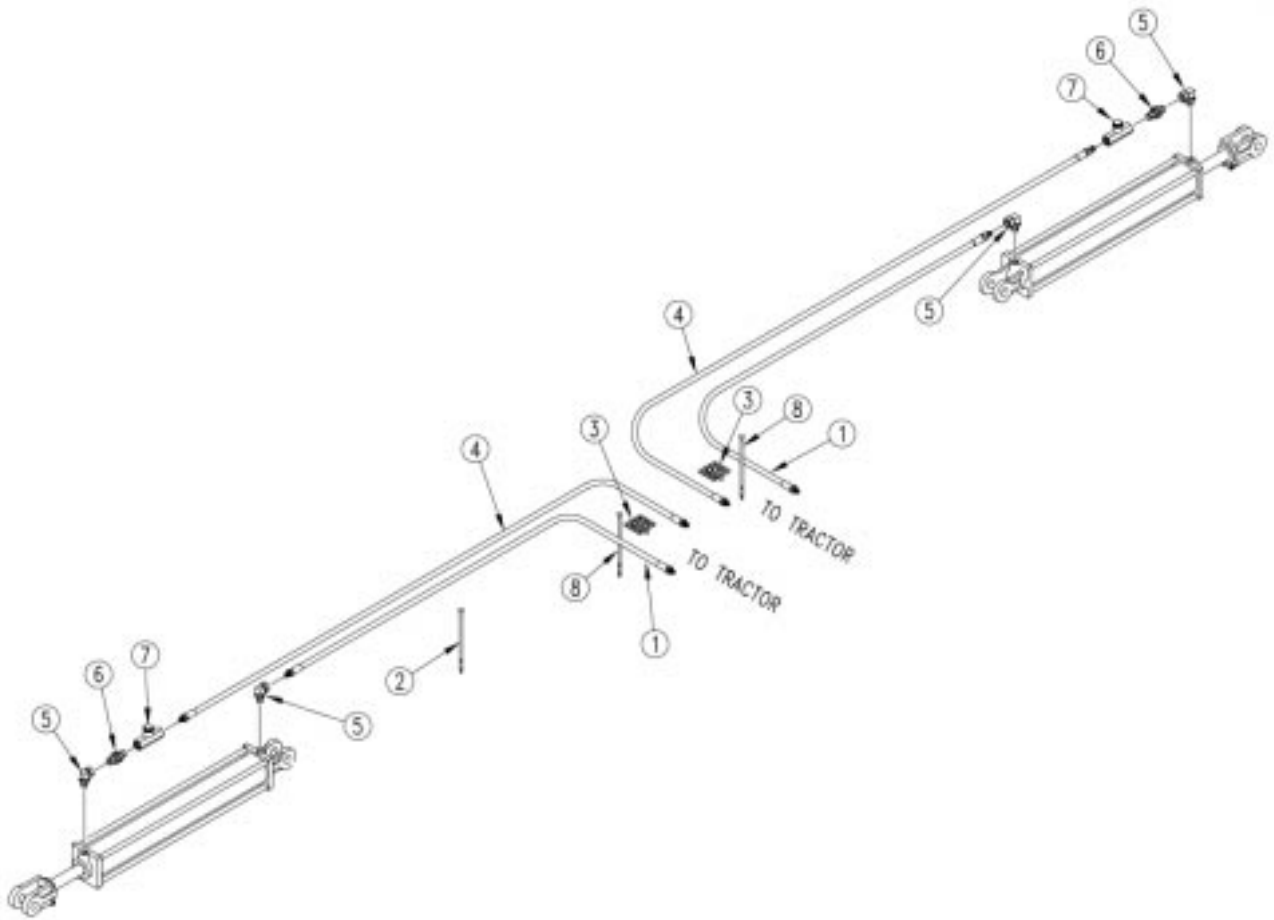

Flat Fold Dual Marker Hydraulics

Ref.	Part No.	Part Description	Comments
1.	811-297C	SP HH1/4R1 212 3/8MNPT-W/AD	
2.	800-082C	CABLE TIE .31X21.5 6DIA 120LB	
3.	817-348C	PLASTIC HOSE LABEL	
4.	811-129C	HH1/4R1 234 3/8MNPT 1/2MNPT	
5.	811-281C	EL 3/8FNPT 9/16MORB	
6.	811-044C	AD 3/8MNPT	
7.	810-058C	VALVE 3/8 NEEDLE	
8.	800-300C	CABLE TIE 2 DIA MIN - ORG	

Flat Fold Marker Sequence Valve Hydraulics

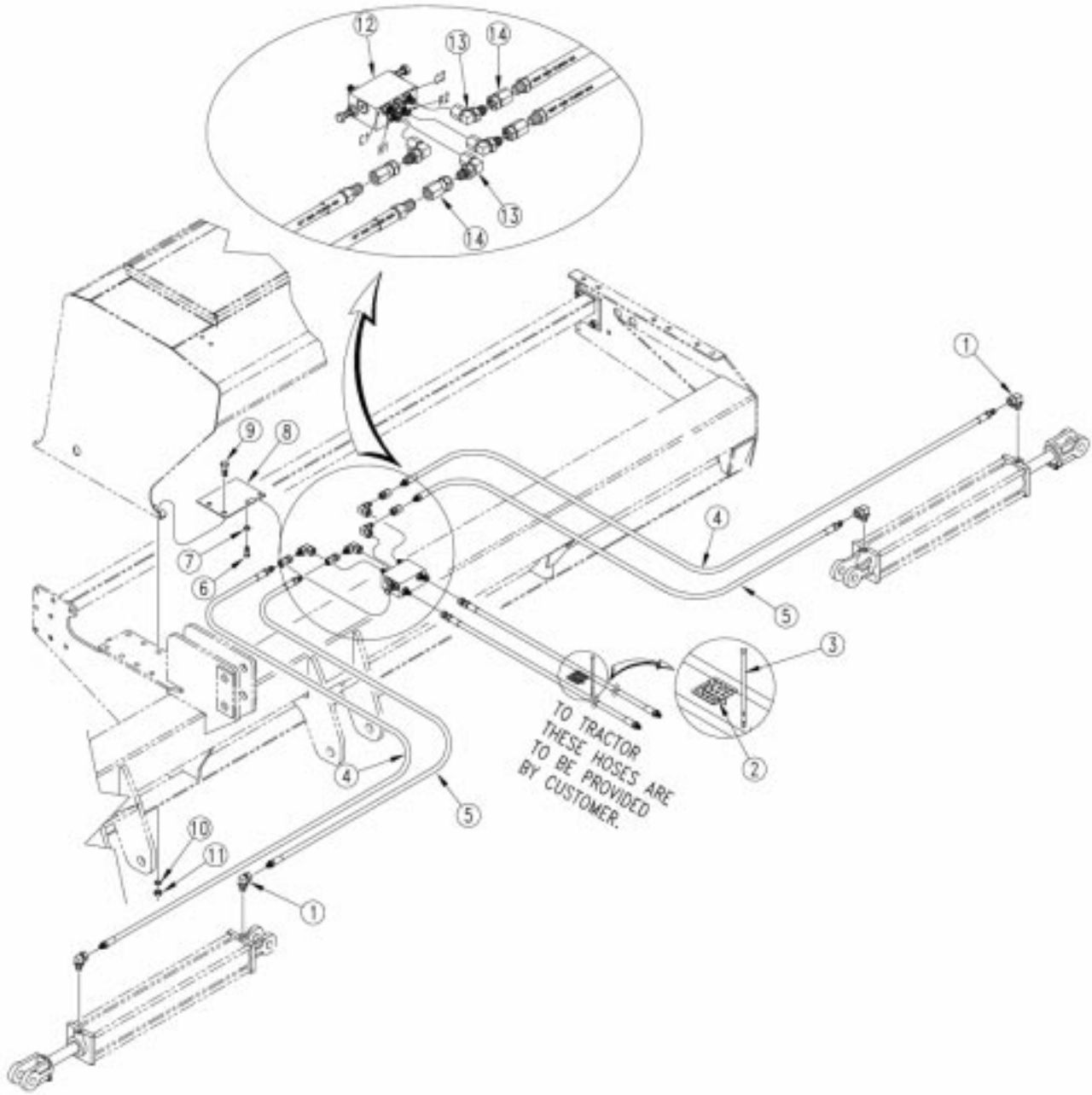

Flat Fold Marker Sequence Valve Hydraulics

Ref.	Part No.	Part Description	Comments
1.	811-281C	EL 3/8FNPT 9/16MORB	
2.	817-348C	PLASTIC HOSE LABEL	
3.	800-300C	CABLE TIE 2 DIA MIN - ORG	
4.	811-129C	HH1/4R1 234 3/8MNPT 1/2MNPT	
5.	811-297C	SP HH1/4R1 212 3/8MNPT-W/AD	
6.	802-014C	HHCS 3/8-16X3/4 GR5	
7.	804-013C	WASHER LOCK SPRING 3/8 PLT	
8.	113-488D	SEQUENCE VALVE MOUNT BRACKET	
9.	802-034C	HHCS 1/2-13X1 1/4 GR5	
10.	804-015C	WASHER LOCK SPRING 1/2 PLT	
11.	803-020C	NUT HEX 1/2-13 PLT	
12.	810-197C	VALVE,SEQUENCE SHOEMAKER	Refer to page 8-11 for breakdown.
13.	811-169C	EL 9/16MJIC 9/16FJIC	
14.	811-440C	AD 1/2FNPT X 9/16FJICS	

Hydraulic Cylinder 2 x 20 x 1.12 (810-205C)

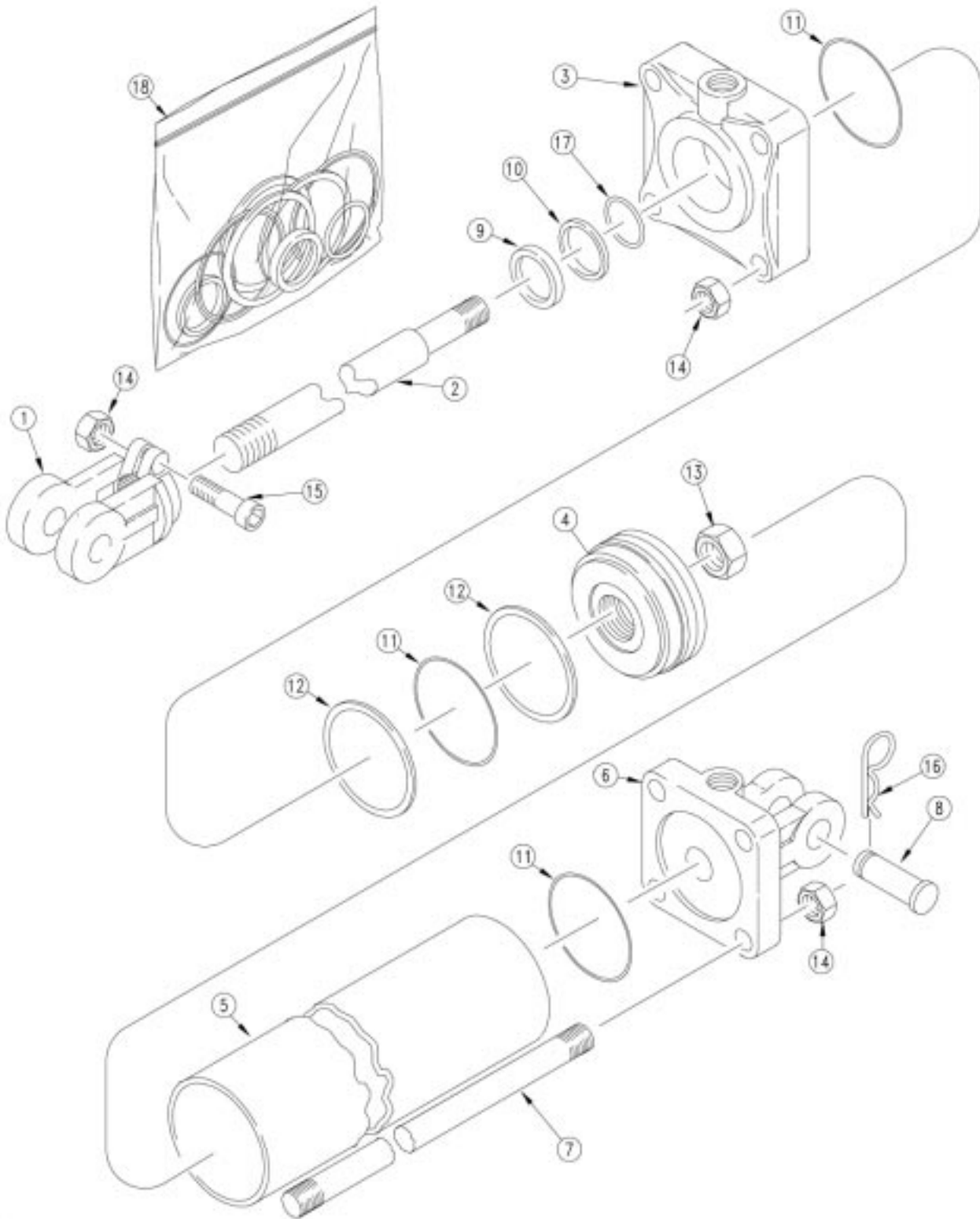

12224

Hydraulic Cylinder 2 x 20 x 1.12 (810-205C)

Ref.	Part No.	Part Description	Comments
1.	1M6006	MW ROD CLEVIS	
2.	2M2326	MW ROD	
3.	3M2310	MW HEAD	
4.	4M2102	MW PISTON	
5.	5M2128	BARREL	
6.	6M2170	MW BASE	
7.	7M2328	MW TIE ROD	
8.	2A0206	MW PIN SHORT	
9.		WIPER SEAL	Only available in seal kit item 18.
10.		BACK-UP	Only available in seal kit item 18.
11.		O-RING	Only available in seal kit item 18.
12.		BACK-UP	Only available in seal kit item 18.
13.	2A0022	MW NUT, PISTON	
14.	2A0012	MW NUT CLEVIS & TIE ROD	
15.	2A0006	MW CAPSCREW	
16.	2A0132	MW PIN CLIP	
17.		O-RING	Only available in seal kit item 18.
18.	810-187C	SEAL KIT CROSS 2 CYL 1C4623	

Sequence Valve (810-197C)

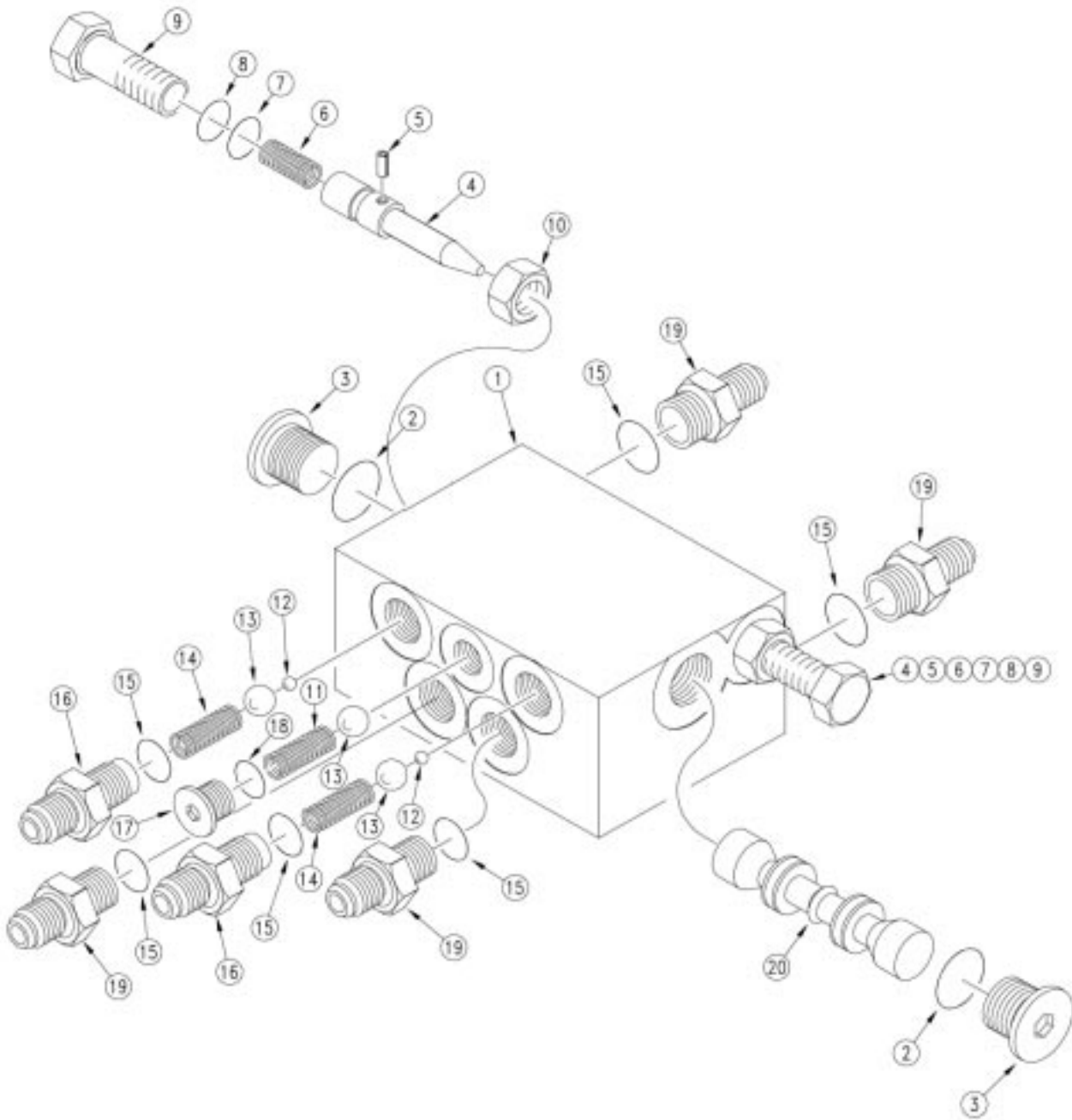

Sequence Valve (810-197C)

Ref.	Part No.	Part Description	Comments
1.	3089	SHOEMAKER BODY MKR SEQ VALVE	
2.	1088-908	SHOEMAKER O-RING	
3.	1132-08	SHOEMAKER PLUG, HEX SOCKET	
4.	1179	SHOEMAKER NEEDLE, FLOW CONTROL	
5.	1217	SHOEMAKER .125 SPRING PIN	
6.	1211	SHOEMAKER SPRING COMPRESSION	
7.	1088-011	RPBY 1100-011	
8.	1089-011	SHOEMAKER TEFLON BACK UP RING	
9.	1180	SHOEMAKER SCREW, FLOW CON. ADJ.	
10.	1218	SHOEMAKER HEX, JAM NUT Z PLTD.	
11.	1099	SHOEMAKER SPRING DETENT	
12.	1087-250	BALL, STEEL 1/4 DIAMETER	
13.	1087-437	SHOEMAKER 7/16 DIA STEEL BALL	
14.	1042	SPRING	
15.	1088-906	SHOEMAKER O-RING	
16.	1182	SHOEMAKER FITTING PORT ADPT.	
17.	1132-05	SHOEMAKER HEX, SKT O-RING PLUG	
18.	1088-905	SHOEMAKER O-RING	
19.	1092-6-6	SHOEMAKER SAE #6 TO #6 STRGHT	
20.	2153	SHOEMAKER SPOOL, MKR SEQ. .055	

Harrow

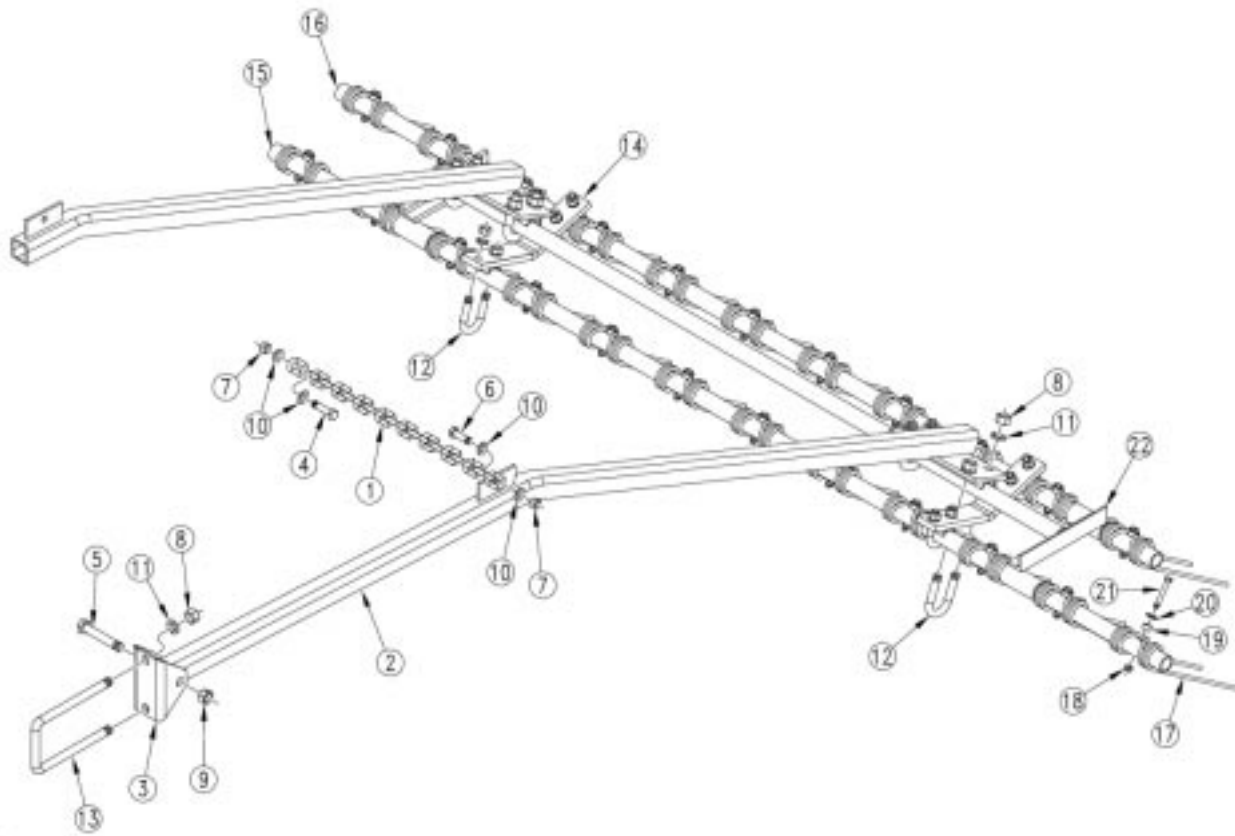

Harrow

Ref.	Part No.	Part Description	Comments
1.	116-191D	3-PT SUPPORT CHAIN LONG	
2.	116-202H	HARROW ARM WELDMENT - 80 INCH	
3.	116-226D	HARROW HINGE BRACKET, 3 IN TB	
4.	802-022C	HHCS 3/8-16X1 1/2 GR5	
5.	802-039C	HHCS 1/2-13X3 GR5	
6.	802-079C	HHCS 3/8-16X1 1/4 GR5	
7.	803-013C	NUT LOCK 3/8-16 PLT	
8.	803-020C	NUT HEX 1/2-13 PLT	
9.	803-147C	NUT HEX NYLOCK 1/2-13	
10.	804-012C	WASHER FLAT 3/8 SAE PLT	
11.	804-015C	WASHER LOCK SPRING 1/2 PLT	
12.	806-046C	U-BOLT 1/2-13 X 1 3/8X2 3/4 LG	
13.	806-122C	U-BOLT 1/2-13 X 3 1/32 X 6	
14.	116-062H	CENTER BRACE WELDMENT	
15.	116-114D	15' TINE TUBE	
16.	116-116D	14' TINE TUBE	
17.	807-079C	HARROW DBL TORSION SPRG 11 IN	
18.	803-084C	NUT HEX NYLOCK 5/16-18 PLT	
19.	890-351C	BUSHING 5/8 OD X 11/32 ID	
20.	804-010C	WASHER FLAT 5/16 USS PLT	
21.	802-138C	HHCS 5/16-18X2 1/4 GR5	
22.	116-065H	15' FRAME WELDMENT	

Monitor (S/N 10681C-)

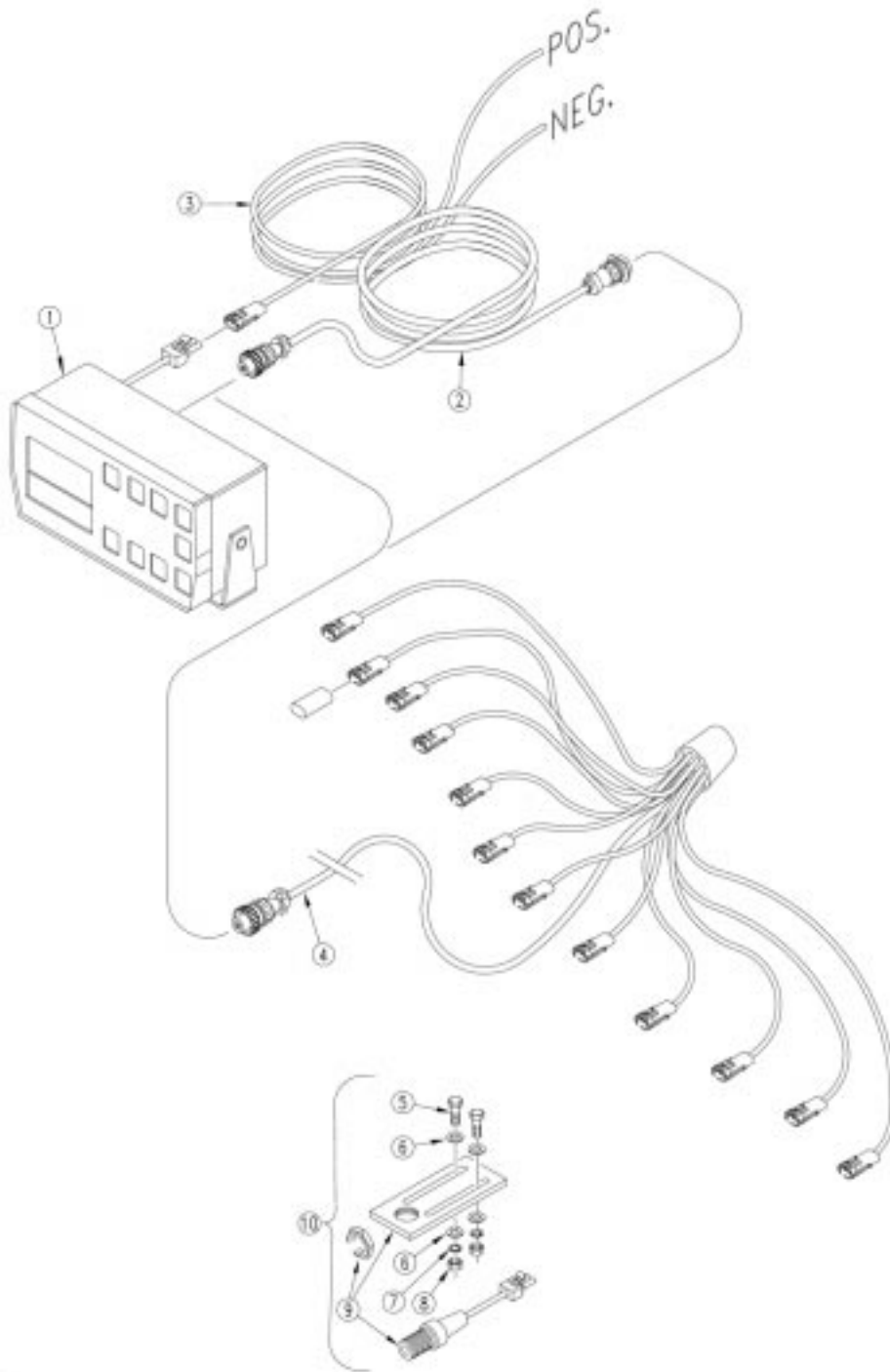

Monitor (S/N 10681C-)

Ref.	Part No.	Part Description	Comments
1.	833-169C	CONSOLE ASSY, DJ 3000	
2.	833-183C	DJ CABLE EXTENSION 15 FT	Use with No-Till Hitches.
3.	833-189C	WIRING HARNESS, BATTERY LEADS	
4.	833-223C	15P 7.5" MONITOR HARNESS	
	833-224C	15P 10" MONITOR HARNESS	
	833-225C	15P 15" MONITOR HARNESS	
5.	802-004C	HHCS 1/4-20X3/4 GR5	
6.	804-007C	WASHER FLAT 1/4 SAE PLT	
7.	804-006C	WASHER LOCK SPRING 1/4 PLT	
8.	803-006C	NUT HEX 1/4-20 PLT	
9.	833-200C	DJ MAGNETIC PICKUP	Includes pickup, jam nut, & plate.
10.	402-151K	MAG PICKUP KIT 10P & 20P	Includes 5,6,7,8 & 9

Monitor 833-279C 7.5" Spacing (S/N 10682C+)

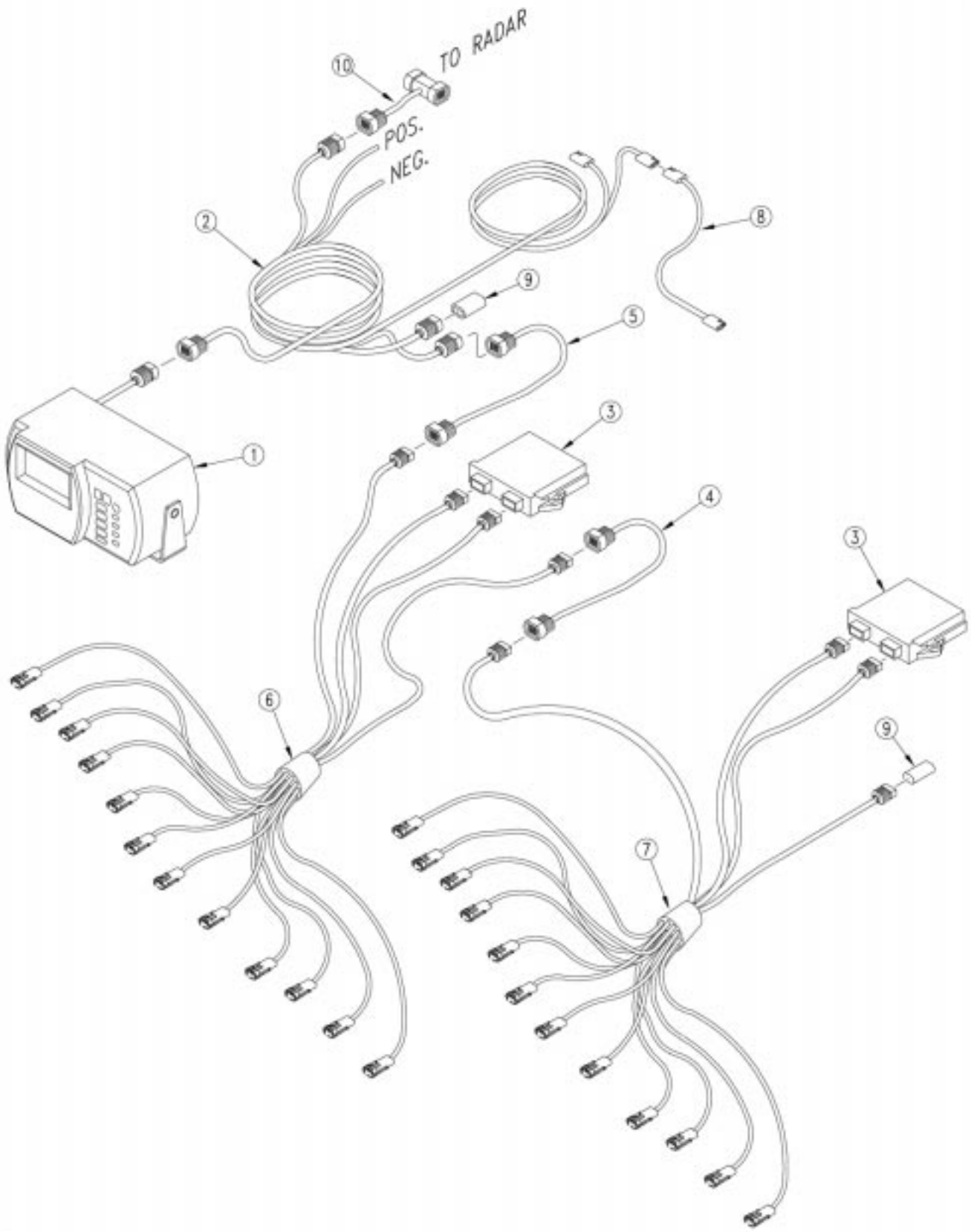

21535

Monitor 833-279C 7.5" Spacing (S/N 10682C+)

Ref.	Part No.	Part Description	Comments
1.	466822000S1	DJ CONSOLE SEED MANAGER SE	
2.	466820134S1	DJ HARNESS EXT PRIMARY SMSE	
3.	467751130S1	DJ MATERIAL FLOW MODULE 16-ROW	
4.	467751200S1	DJ HARNESS EXTENSION 4' SM	
5.	467751206S1	DJ HARNESS EXTENSION 30' SMSE	
6.	467751430S1	DJ HARN, 12R 15P 7.5 LH	
7.	467751431S1	DJ HARN, 12R 15P 7.5 RH	
8.	466820835S1	DJ HARN, EXT 30', 2 PIN	
9.	464211340	DJ DUST CAP, CONN 6 PIN	
10.	833-197C	DJ Y-CABLE CNH MAGNUM	
	833-198C	DJ Y-CABLE MAGNAVOX ADAPTER	
	833-199C	DJ Y-CABLE GENESIS	
	833-195C	DJ Y-CABLE CAT 65,75 A & B	
	833-196C	DJ Y-CABLE CAT 35-55-65-95E	

Monitor 833-280C 10" Spacing (S/N 10682C+)

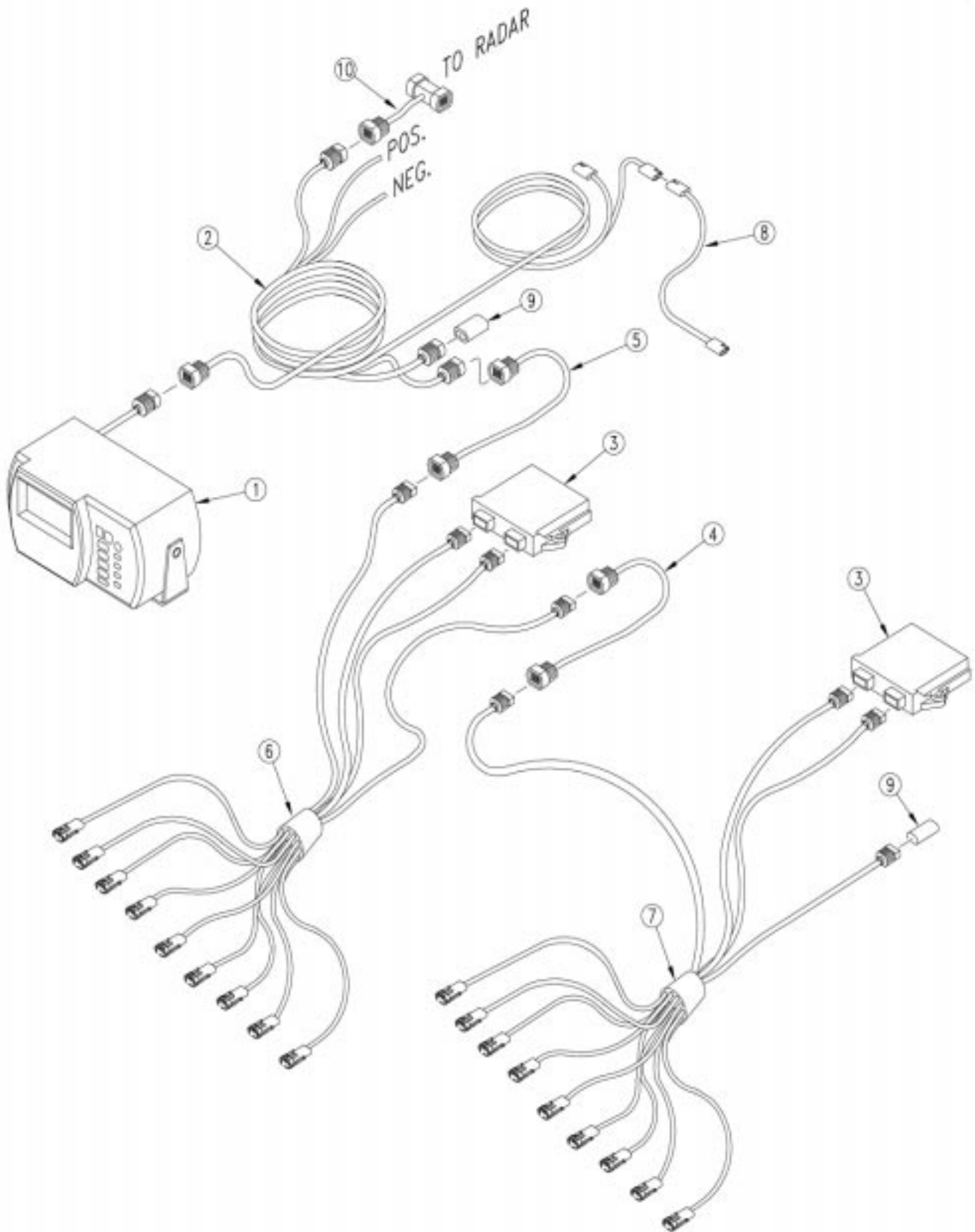

21536

Monitor 833-280C 10" Spacing (S/N 10682C+)

Ref.	Part No.	Part Description	Comments
1.	466822000S1	DJ CONSOLE SEED MANAGER SE	
2.	466820134S1	DJ HARNESS EXT PRIMARY SMSE	
3.	467751130S1	DJ MATERIAL FLOW MODULE 16-ROW	
4.	467751200S1	DJ HARNESS EXTENSION 4' SM	
5.	467751206S1	DJ HARNESS EXTENSION 30' SMSE	
6.	467751410S1	DJ HARN 9R 12P 10 LH	
7.	467751411S1	DJ HARN 9R 12P 10 RH	
8.	466820835S1	DJ HARN, EXT 30', 2 PIN	
9.	464211340	DJ DUST CAP, CONN 6 PIN	
10.	833-197C	DJ Y-CABLE CNH MAGNUM	
	833-198C	DJ Y-CABLE MAGNAVOX ADAPTER	
	833-199C	DJ Y-CABLE GENESIS	
	833-195C	DJ Y-CABLE CAT 65,75 A & B	
	833-196C	DJ Y-CABLE CAT 35-55-65-95E	

Monitor 833-281C 15" Spacing (S/N 10682C+)

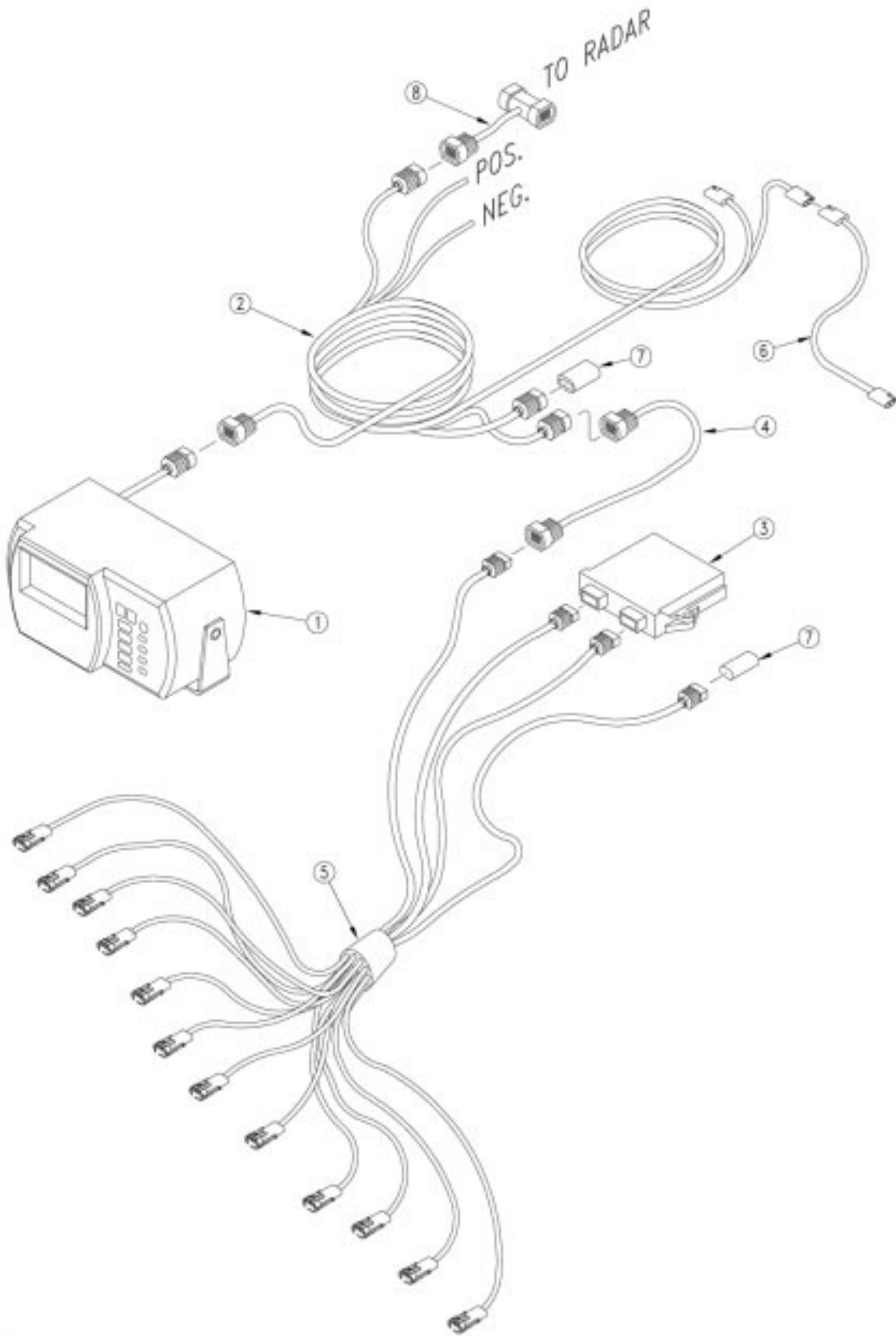

Monitor 833-281C 15" Spacing (S/N 10682C+)

Ref.	Part No.	Part Description	Comments
1.	466822000S1	DJ CONSOLE SEED MANAGER SE	
2.	466820134S1	DJ HARNESS EXT PRIMARY SMSE	
3.	467751130S1	DJ MATERIAL FLOW MODULE 16-ROW	
4.	467751206S1	DJ HARNESS EXTENSION 30' SMSE	
5.	467751432S1	DJ HARN, 12R 12P 15	
6.	466820835S1	DJ HARN, EXT 30', 2 PIN	
7.	464211340	DJ DUST CAP, CONN 6 PIN	
8.	833-197C	DJ Y-CABLE CNH MAGNUM	
	833-198C	DJ Y-CABLE MAGNAVOX ADAPTER	
	833-199C	DJ Y-CABLE GENESIS	
	833-195C	DJ Y-CABLE CAT 65,75 A & B	
	833-196C	DJ Y-CABLE CAT 35-55-65-95E	

Twin Row Baffle

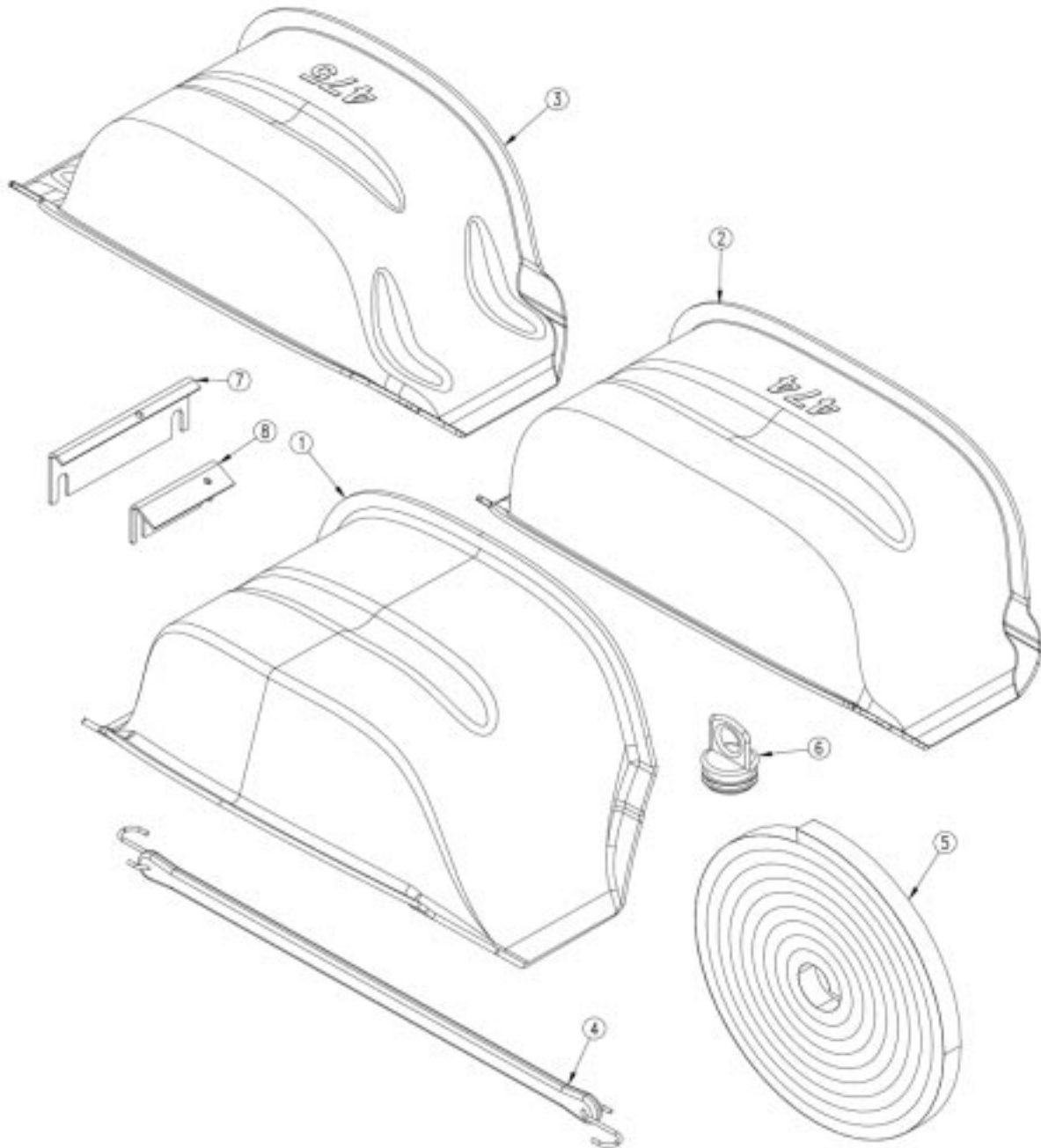

Twin Row Baffle

11

Ref.	Part No.	Part Description	Comments
1.	817-466C	TWIN ROW METER COVER	
2.	817-474C	7 1/2 TO 30IN SPACING COVER	
3.	817-475C	10-30IN SPACING COVER	
4.	816-369C	TARP STRAP 20 WITH HOOKS	
5.	890-750C	FOAM SEAL 1/2 X 3/4 X 204	
6.	816-366C	SEEDTUBE CORK	
7.	118-597D	OUTER BOX END CLIP	
8.	118-596D	INNER BOX END CLIP	

Legend: ● = 1st revision; ● = 2nd revision; ● = 3rd revision; ● = use up existing stock; ⊗ = not interchangeable; ⊗ ① ● = for example: revision 2 is not interchangeable w/revision 1

Microband Twin Row Components (S/N 10513C-)

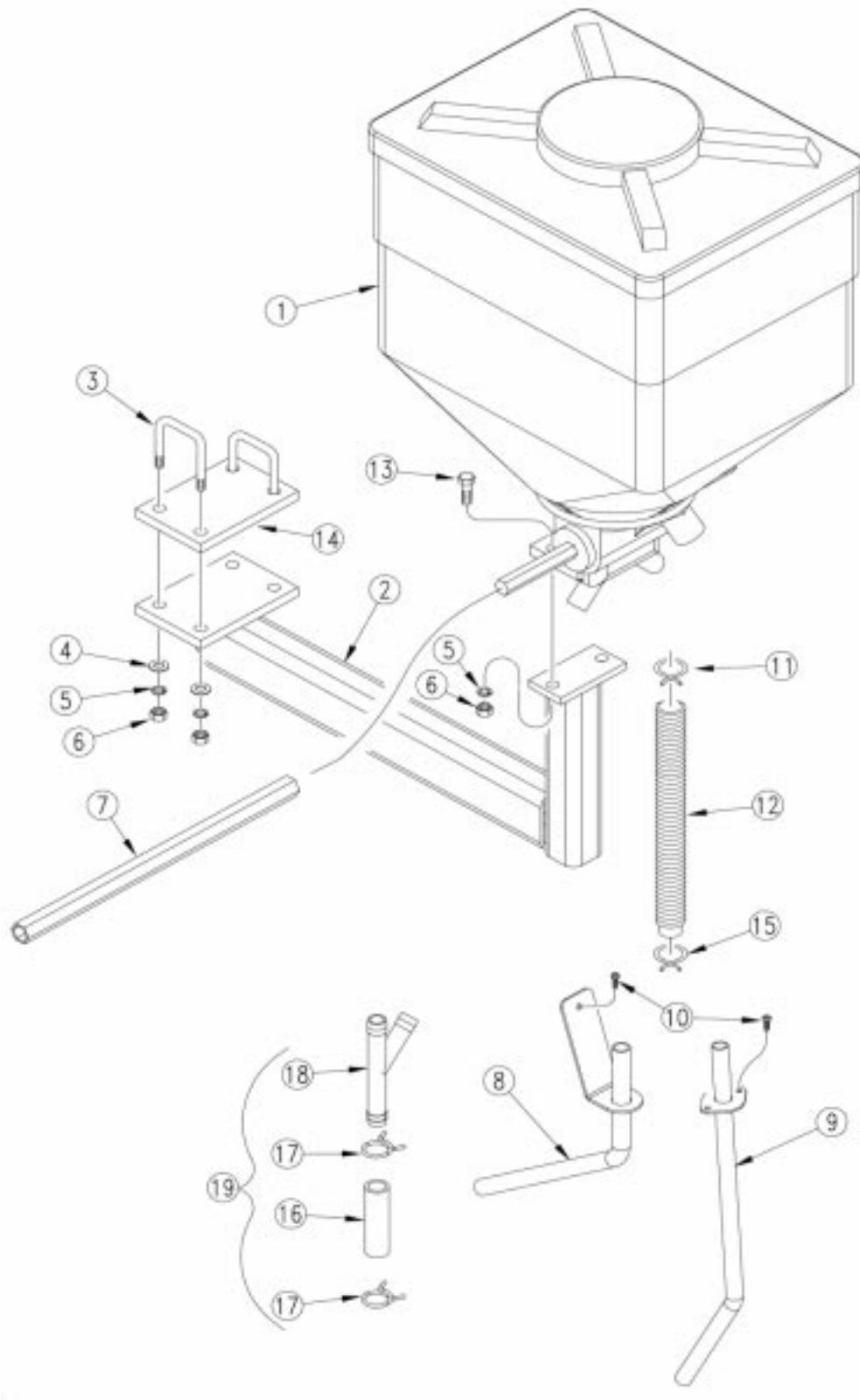

Microband Twin Row Components (S/N 10513C-)

12

Ref.	Part No.	Part Description	Comments
1.	817-464C	MICROBAND 2 OUTLET HOPPER	
2.	116-218H	HOPPER MOUNT ARM	
3.	806-092C	U-BOLT 1/2-13 X 2 X 4	
4.	804-017C	WASHER FLAT 1/2 USS PLT	
5.	804-015C	WASHER LOCK SPRING 1/2 PLT	
6.	803-020C	NUT HEX 1/2-13 PLT	
7.	116-248D	MB CONNECTOR TUBE 21"	
8.	116-221H	20 SERIES INSECTICIDE TUBE	
9.	116-220H	10 SERIES INSECTICIDE TUBE	
10.	801-002C	SCREW HEX SLT10-16X3/8P.THD CT	
11.	800-323C	CLAMP HOSE 1 1/16 NO. 17	
12.	116-247D	MB INSECTICIDE HOSE	
13.	802-091C	HHCS 1/2-13X1 1/2 GR5	
14.	116-232D	MB SPACER PLATE	
15.	800-321C	HOSE CLAMP NO.12 3/4 ID	
16.	133-064D	Y-TUBE CONNECTOR HOSE	
17.	800-029C	CLAMP HOSE GRASS SEED	
18.	817-481C	HOSE BARB Y-5/8"X5/8"X5/8	
19.	133-192V	SMLS DS WITH MICROBAND Y-TUBE	Only with small seeds option

Legend: ● = 1st revision; ● = 2nd revision; ● = 3rd revision; ● = use up existing stock; ⊗ = not interchangeable; ⊗ ① ● = for example: revision 2 is not interchangeable w/revision 1

Microband Every Row Components (S/N 10513C-)

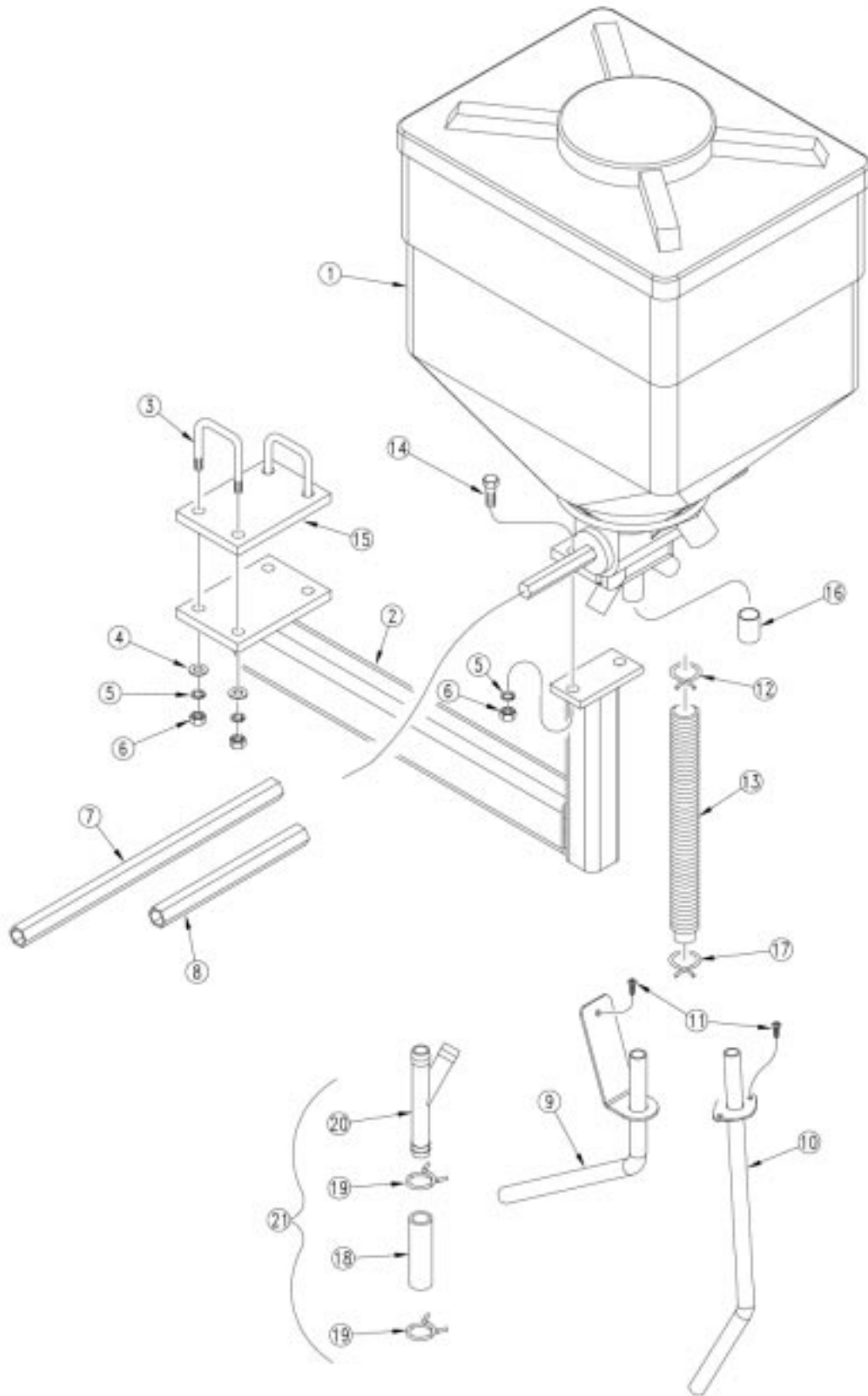

Microband Every Row Components (S/N 10513C-)

Ref.	Part No.	Part Description	Comments
1.	817-465C	MICROBAND 3 OUTLET HOPPER	
2.	116-218H	HOPPER MOUNT ARM	
3.	806-092C	U-BOLT 1/2-13 X 2 X 4	
4.	804-017C	WASHER FLAT 1/2 USS PLT	
5.	804-015C	WASHER LOCK SPRING 1/2 PLT	
6.	803-020C	NUT HEX 1/2-13 PLT	
7.	116-249D	MB CONNECTOR TUBE 13 1/2"	
8.	116-250D	MB CONNECTOR TUBE 10"	
9.	116-221H	20 SERIES INSECTICIDE TUBE	
10.	116-220H	10 SERIES INSECTICIDE TUBE	
11.	801-002C	SCREW HEX SLT10-16X3/8P.THD CT	
12.	800-029C	CLAMP HOSE GRASS SEED	
13.	116-247D	MB INSECTICIDE HOSE	
14.	802-091C	HHCS 1/2-13X1 1/2 GR5	
15.	116-232D	MB SPACER PLATE	
16.	817-136C	CAPLUG 3/4 VINYL # VC 750	
17.	800-321C	HOSE CLAMP NO.12 3/4 ID	
18.	133-064D	Y-TUBE CONNECTOR HOSE	
19.	800-029C	CLAMP HOSE GRASS SEED	
20.	817-481C	HOSE BARB Y-5/8"X5/8"X5/8	
21.	133-192V	SMLS DS WITH MICROBAND Y-TUBE	Only with small seeds option

Legend: ● = 1st revision; ● = 2nd revision; ● = 3rd revision; ● = use up existing stock; ⊗ = not interchangeable; ⊗ ① ● = for example: revision 2 is not interchangeable w/revision 1

Microband Components (S/N 10542C+)

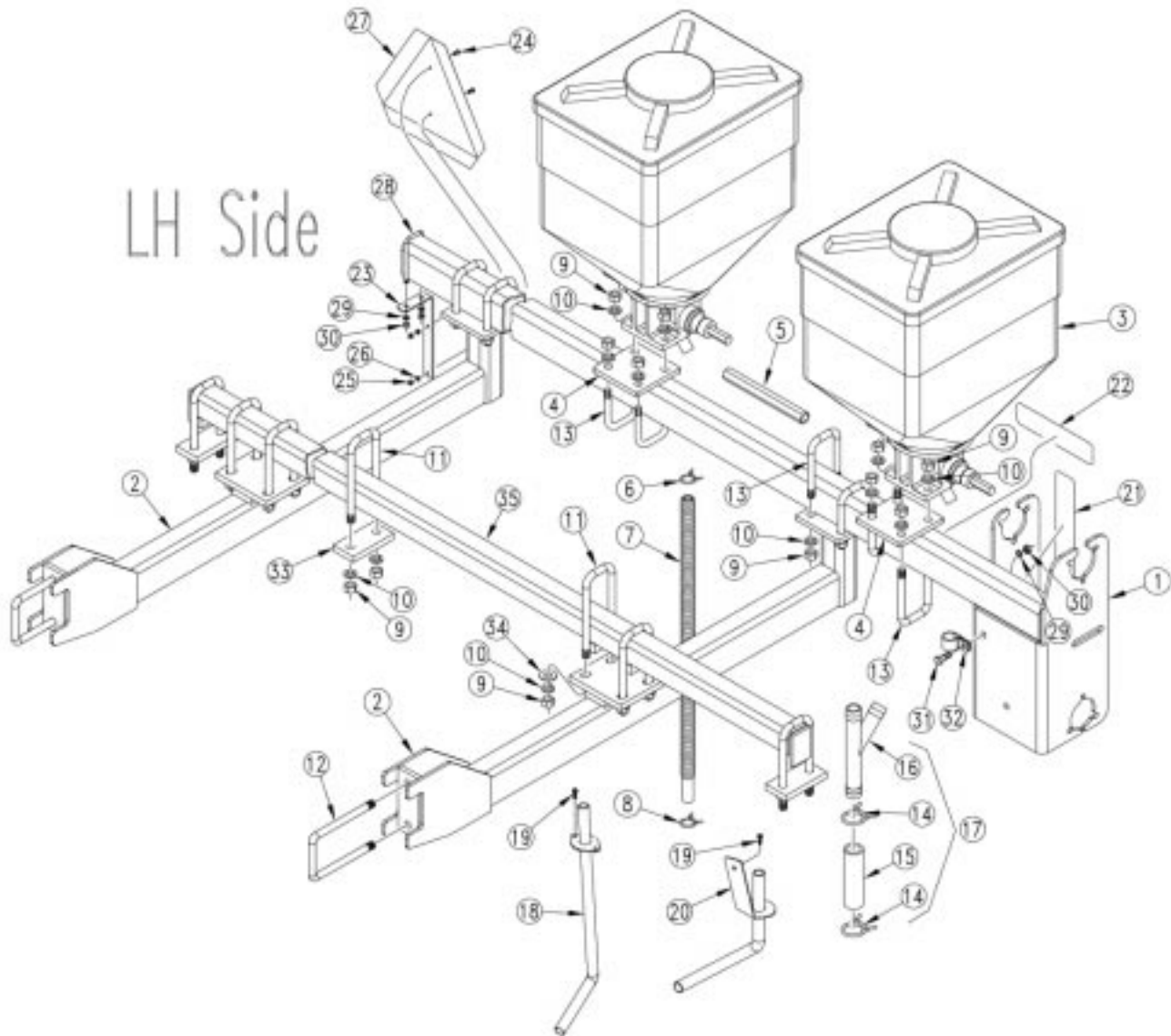

Microband Components (S/N 10542C +)

Ref.	Part No.	Part Description	Comments
1.	116-244H	15' MB LH DRIVE	Shown.
	116-245H	15' MB RH DRIVE	
2.	116-243H	MB HOPPER MOUNT ARM	
3.	817-464C	MICROBAND 2 OUTLET HOPPER	
	817-465C	MICROBAND 3 OUTLET HOPPER	
4.	116-272D	MB HOPPER MOUNTING PLATE	
5.	116-248D	MB CONNECTOR TUBE 21"	
	116-249D	MB CONNECTOR TUBE 13 1/2"	
	116-250D	MB CONNECTOR TUBE 10"	
	116-281D	MB CONNECTOR TUBE 6 3/4"	
	116-282D	MB CONNECTOR TUBE 18"	
6.	800-323C	CLAMP HOSE 1 1/16 NO. 17	
	800-029C	CLAMP HOSE GRASS SEED	
7.	116-247D	MB INSECTICIDE HOSE	
8.	800-321C	HOSE CLAMP NO.12 3/4 ID	
9.	803-020C	NUT HEX 1/2-13 PLT	
10.	804-015C	WASHER LOCK SPRING 1/2 PLT	
11.	806-163C	U-BOLT 1/2-13 X 2 1/32 X 6 1/2	
12.	806-122C	U-BOLT 1/2-13 X 3 1/32 X 6	
13.	806-168C	U-BOLT 1/2-13 X 2 1/32 X 4 1/2	
14.	800-029C	CLAMP HOSE GRASS SEED	
15.	133-064D	Y-TUBE CONNECTOR HOSE	
16.	817-481C	HOSE BARB Y-5/8"X5/8"X5/8	
17.	133-192V	SMLS DS WITH MICROBAND Y-TUBE	Used with small seeds option.
18.	116-220H	10 SERIES INSECTICIDE TUBE	
19.	801-002C	SCREW HEX SLT10-16X3/8P.THD CT	
20.	116-221H	20 SERIES INSECTICIDE TUBE	
21.	838-266C	DECAL REFLECTOR RED 1 1/2X9	
22.	838-267C	DECAL REFLECTR DAYTIME 1 1/2X9	
23.	133-060D	SMV MOUNT BRACKET	
24.	801-018C	SCREW RD HD 1/4-20 X 5/8	
25.	803-006C	NUT HEX 1/4-20 PLT	
26.	804-006C	WASHER LOCK SPRING 1/4 PLT	
27.	818-055C	DECAL SLOW MOVING-GALV. BACKED	
28.	806-001C	U-BOLT 3/8-16 X 2 X 4	
29.	804-013C	WASHER LOCK SPRING 3/8 PLT	
30.	803-014C	NUT HEX 3/8-16 PLT	
31.	802-079C	HHCS 3/8-16X1 1/4 GR5	
32.	800-064C	HOSE CLIP 13/16 ID	
33.	116-290D	MB TRUSS BOLT PLATE	
34.	804-016C	WASHER FLAT 1/2 SAE PLT	
35.	116-262H	15' MB TUBE TRUSS	

Legend: ● = 1st revision; ● = 2nd revision; ● = 3rd revision; ● = use up existing stock; ⊗ = not interchangeable; ⊗ ① ● = for example: revision 2 is not interchangeable w/revision 1

Microband Hopper Components

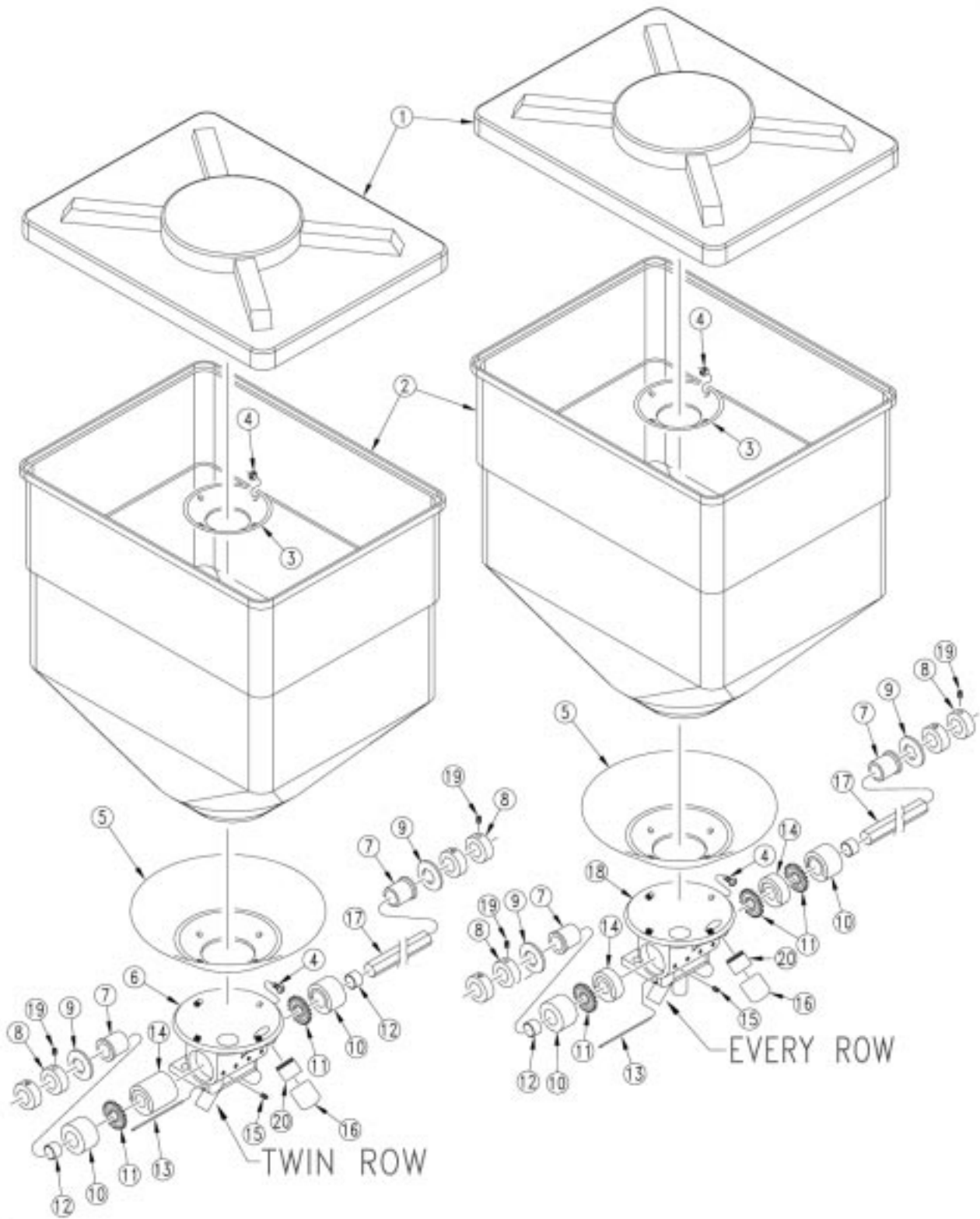

Microband Hopper Components

Ref.	Part No.	Part Description	Comments
1.	200084	MB 35 LTR RECTANGULAR HPPR LID	
2.	200083	MB 35 LITRE RECTANGULAR HPPR	
3.	001029	MB HOPPER CLAMPING RING	
4.	301041	MB RND HD BOLT M6 X 25 C/W NUT	
5.	098016	MB HOPPER GASKET	
6.	003010	MB BODY HOUSING - 2 OUTLET	
7.	004001	MB ADAPTOR BUSH	
8.	160011	MB HEXAGON SHAFT COLLAR	
9.	018028	MB RUBBER SHAFT SEALING WASHER	
10.	003018	MB HOUSING BEARING ASSEMBLY	
11.	094008	MB 8MM (5/16") ROTOR (18-FLTD)	
12.	038004	MB OILITE BEARING BUSH	
13.	095003	MB WEAR STRIP	
14.	006094	MB 20MM SPACER (3/4")	
15.	302010	MB HA SCR M8 X 8 (PLAIN POINT)	
16.	075020	MB DRAIN CAP	
17.	012114	MB HEX DRV SHFT 0.6" A/F X305	
18.	003029	MB BODY HOUSING - 3 OUTLET	
19.	302009	MB HA SCR M8 X 8 KNURLED POINT	
20.	137084	MB DRAIN TUBE	

Legend: ● = 1st revision; ● = 2nd revision; ● = 3rd revision; ● = use up existing stock; ⊗ = not interchangeable; ⊗ ① ● = for example: revision 2 is not interchangeable w/revision 1

Microband Drive (S/N 10513C-)

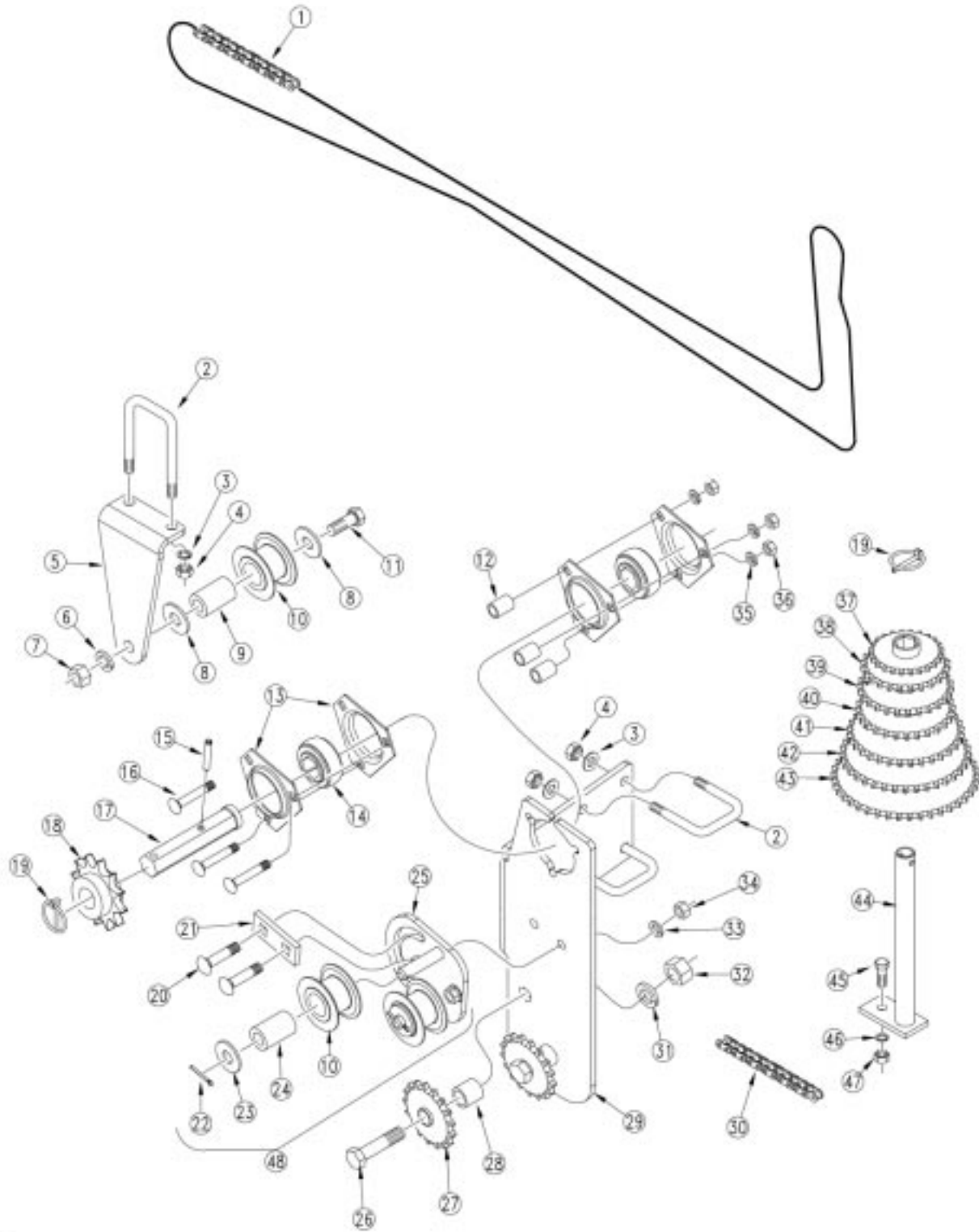

Microband Drive (S/N 10513C-)

Ref.	Part No.	Part Description	Comments
1.	136-184D	CHAIN RL #40 347 PITCHES	
2.	806-004C	U-BOLT 3/8-16 X 2 X 2 3/4	
3.	804-013C	WASHER LOCK SPRING 3/8 PLT	
4.	803-014C	NUT HEX 3/8-16 PLT	
5.	116-241D	MB IDLER MOUNT	
6.	804-015C	WASHER LOCK SPRING 1/2 PLT	
7.	803-020C	NUT HEX 1/2-13 PLT	
8.	804-017C	WASHER FLAT 1/2 USS PLT	
9.	120-306D	TUBE RND 1 OD X 7/32W X 2.13	
10.	817-456C	IDLER SPOOL #50 2.38X1.01X1.31	
11.	802-099C	HHCS 1/2-13X3 1/4 GR5	
12.	116-239D	MB BEARING MOUNT SPACER	
13.	822-175C	FLANGETTE 52 3-BOLT PLT	
14.	822-195C	BRG.7/8HEX 52MM SPHR OD PEER	
15.	805-180C	PIN ROLL 1/4 X 1 1/2 LG PLT	
16.	802-199C	RHSNB 5/16-18X2 GR5	
17.	116-219H	DRIVE SHAFT COUPLER	
18.	808-219C	SPKT 40C12 X 7/8 HEX BORE	
19.	805-240C	PIN LYNCH 3/16 X 1 9/16 LONG	
20.	802-252C	RHSNB 3/8-16X1 3/4 GR5	
21.	402-242D	IDLER BOLT PLATE	
22.	805-064C	PIN COTTER 7/64 X 1 LONG	
23.	804-017C	WASHER FLAT 1/2 USS PLT	
24.	120-305D	TUBE RND 1 OD X 7/32W X 1.56	
25.	402-126H	OFFSET DOUBLE IDLER WELDMENT	
26.	802-259C	HHCS 5/8-18X2 3/4 GR5	
27.	808-046C	SPKT 40A17 IDLER	
28.	116-240D	MB IDLER SPACER	
29.	116-236D	MB DRIVE MOUNT LH	
30.	136-184D	CHAIN RL #40 347 PITCHES	
31.	804-022C	WASHER LOCK SPRING 5/8 PLT	
32.	803-021C	NUT HEX 5/8-11 PLT	
33.	804-013C	WASHER LOCK SPRING 3/8 PLT	
34.	803-014C	NUT HEX 3/8-16 PLT	
35.	804-009C	WASHER LOCK SPRING 5/16 PLT	
36.	803-008C	NUT HEX 5/16-18 PLT	
37.	808-148C	SPKT 40C17 X 7/8 HEX BORE	
38.	808-151C	SPKT 40C24 X 7/8 HEX BORE	
39.	808-153C	SPKT 40C26 X 7/8 HEX BORE	
40.	808-154C	SPKT 40C27 X 7/8 HEX BORE	
41.	808-223C	SPKT 40C32 X 7/8 HEX BORE	
42.	808-251C	SPKT 40C36 X 7/8 HEX BORE	
43.	808-224C	SPKT 40C41 X 7/8 HEX BORE	
44.	402-022H	SPRKT STORAGE WELD	
45.	802-022C	HHCS 3/8-16X1 1/2 GR5	
46.	804-013C	WASHER LOCK SPRING 3/8 PLT	
47.	803-014C	NUT HEX 3/8-16 PLT	
48.	196-249S	DOUBLE IDLER SPOOL ASSY #50	Includes 10,22,23,24 & 25

Legend: ● = 1st revision; ● = 2nd revision; ● = 3rd revision; ● = use up existing stock; ⊗ = not interchangeable; ⊗ ① ● = for example: revision 2 is not interchangeable w/revision 1

Microband Drive (S/N 10542+)

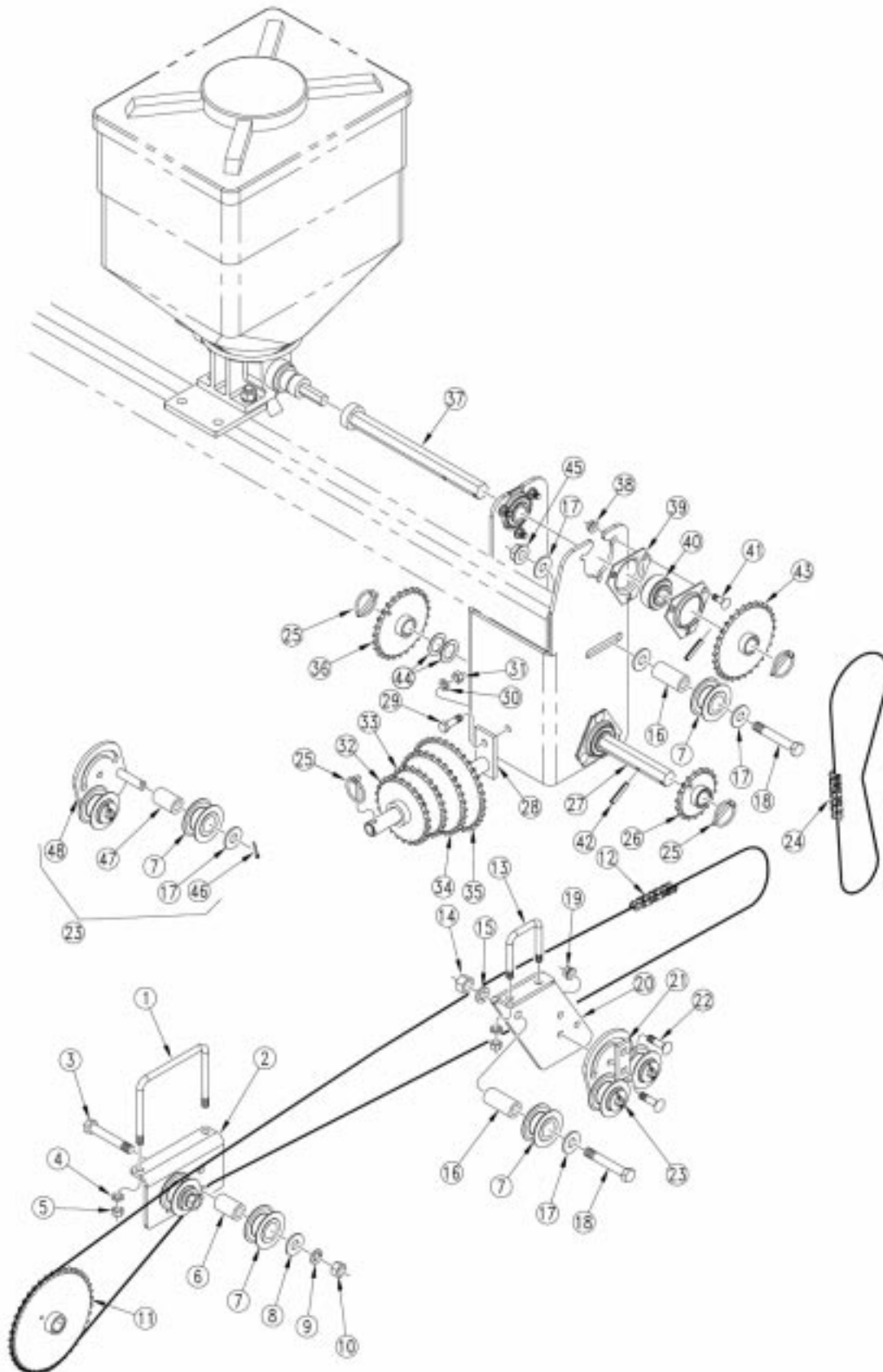

19697

Microband Drive (S/N 10542 +)

Ref.	Part No.	Part Description	Comments
1.	806-165C	U-BOLT 3/8-16 X 5 1/32 X 4 1/4	
2.	116-279D	MB CHAIN IDLER MOUNT	
3.	802-130C	HHCS 1/2-13X2 1/2 GR5	
4.	804-013C	WASHER LOCK SPRING 3/8 PLT	
5.	803-014C	NUT HEX 3/8-16 PLT	
6.	120-305D	TUBE RND 1 OD X 7/32W X 1.56	
7.	817-406C	IDLER 1 PC 2.38X1.01X1.062	
8.	804-017C	WASHER FLAT 1/2 USS PLT	
9.	804-015C	WASHER LOCK SPRING 1/2 PLT	
10.	803-020C	NUT HEX 1/2-13 PLT	
11.	808-224C	SPKT 40C41 X 7/8 HEX BORE	
12.	136-187D	CHAIN RL #40 310 PITCHES W/CON	
13.	806-004C	U-BOLT 3/8-16 X 2 X 2 3/4	
14.	803-020C	NUT HEX 1/2-13 PLT	
15.	804-015C	WASHER LOCK SPRING 1/2 PLT	
16.	120-306D	TUBE RND 1 OD X 7/32W X 2.13	
17.	804-017C	WASHER FLAT 1/2 USS PLT	
18.	802-099C	HHCS 1/2-13X3 1/4 GR5	
19.	803-209C	NUT FLANGE LOCK 3/8-16 PLT	
20.	116-277D	MB DRIVE TENSIONER BRACKET	
21.	402-242D	IDLER BOLT PLATE	
22.	802-453C	RHSNB 3/8-16X1 1/2 GR5	
23.	402-140S	DOUBLE SPOOL IDLER ASSY	Includs 7,17,46,47 & 48
24.	136-113D	CHAIN RL #40 78 PITCHES	
25.	805-240C	PIN LYNCH 3/16 X 1 9/16 LONG	
26.	808-149C	SPKT 40C19 X 7/8 HEX BORE	
27.	116-274D	MB JACK SHAFT	
28.	402-022H	SPRKT STORAGE WELD	
29.	802-079C	HHCS 3/8-16X1 1/4 GR5	
30.	804-013C	WASHER LOCK SPRING 3/8 PLT	
31.	803-014C	NUT HEX 3/8-16 PLT	
32.	808-153C	SPKT 40C26 X 7/8 HEX BORE	
33.	808-154C	SPKT 40C27 X 7/8 HEX BORE	
34.	808-223C	SPKT 40C32 X 7/8 HEX BORE	
35.	808-251C	SPKT 40C36 X 7/8 HEX BORE	
36.	808-151C	SPKT 40C24 X 7/8 HEX BORE	
37.	116-248H	MD DRIVE SHAFT COUPLER	
38.	803-177C	NUT HEX LOCK 5/16-18 FLG.	
39.	822-175C	FLANGETTE 52 3-BOLT PLT	
40.	822-195C	BRG.7/8HEX 52MM SPHR OD PEER	
41.	802-282C	RHSNB 5/16-18X1 GR5	
42.	805-180C	PIN ROLL 1/4 X 1 1/2 LG PLT	
43.	808-156C	SPKT 40C30 X 7/8 HEX BORE	
44.	804-061C	WASHER MACH 1.50 X 1.00 X 18GA	
45.	803-169C	NUT HEX FLG. LOCK 1/2-13 PLT.	
46.	805-064C	PIN COTTER 7/64 X 1 LONG	
47.	120-305D	TUBE RND 1 OD X 7/32W X 1.56	
48.	402-126H	OFFSET DOUBLE IDLER WELDMENT	

Legend: ● = 1st revision; ● = 2nd revision; ● = 3rd revision; ● = use up existing stock; ⊗ = not interchangeable; ⊗ ① ● = for example: revision 2 is not interchangeable w/revision 1

Small Seeds Box Mounting

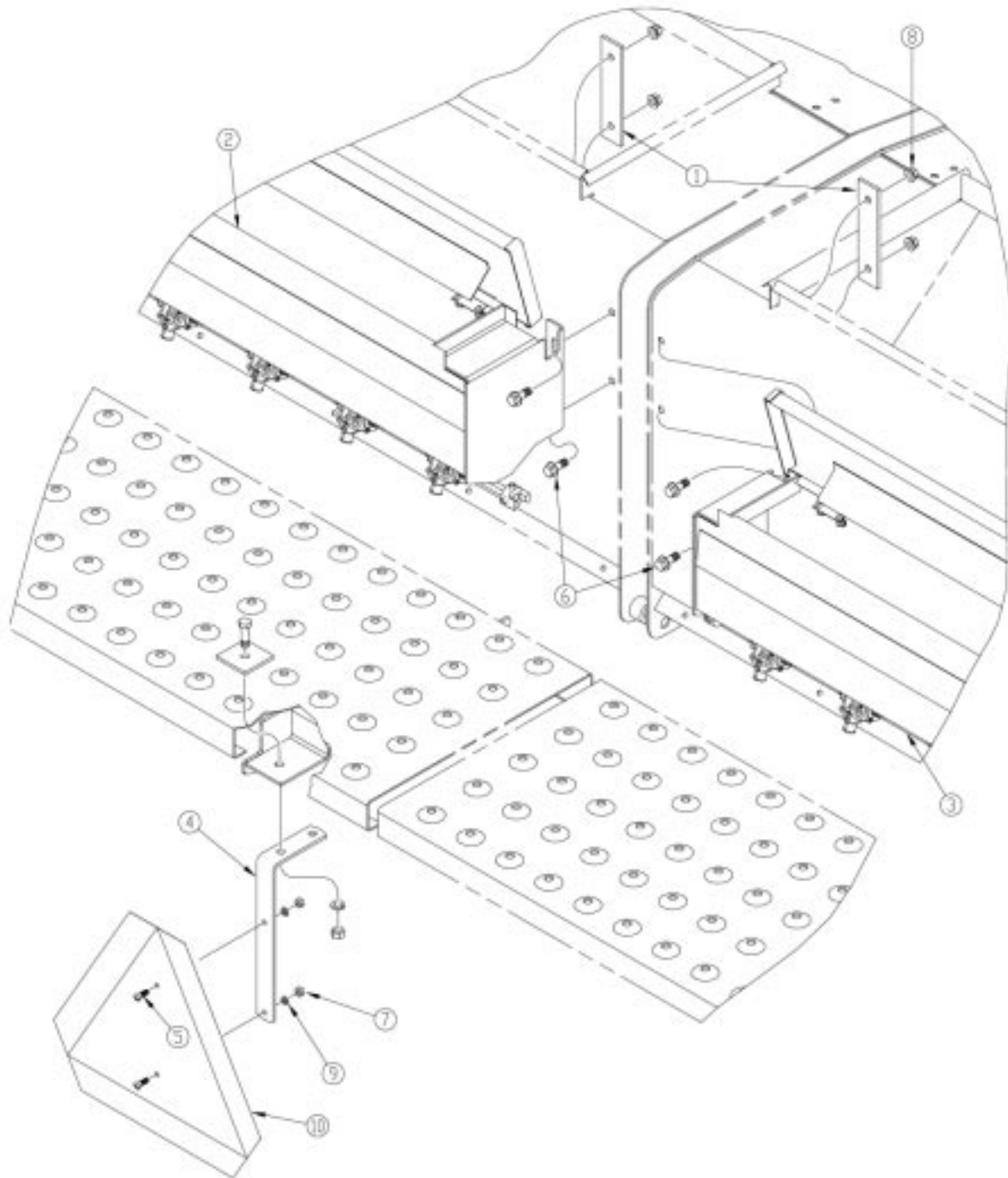

Small Seeds Box Mounting

Ref.	Part No.	Part Description	Comments
1.	123-520D	SEED BOX REINFORCEMENT STRAP	
2.	123-803L	3PT 15'-7.5SML SD BOX ASSY LH	
3.	123-804L	3PT 15'-7.5SML SD BOX ASSY RH	
4.	133-060D	SMV MOUNT BRACKET	
5.	801-018C	SCREW RD HD 1/4-20 X 5/8	
6.	802-388C	HFS 3/8-16X1 GR5	
7.	803-006C	NUT HEX 1/4-20 PLT	
8.	803-209C	NUT FLANGE LOCK 3/8-16 PLT	
9.	804-006C	WASHER LOCK SPRING 1/4 PLT	
10.	818-055C	DECAL SLOW MOVING-GALV. BACKED	

Small Seeds Box Components

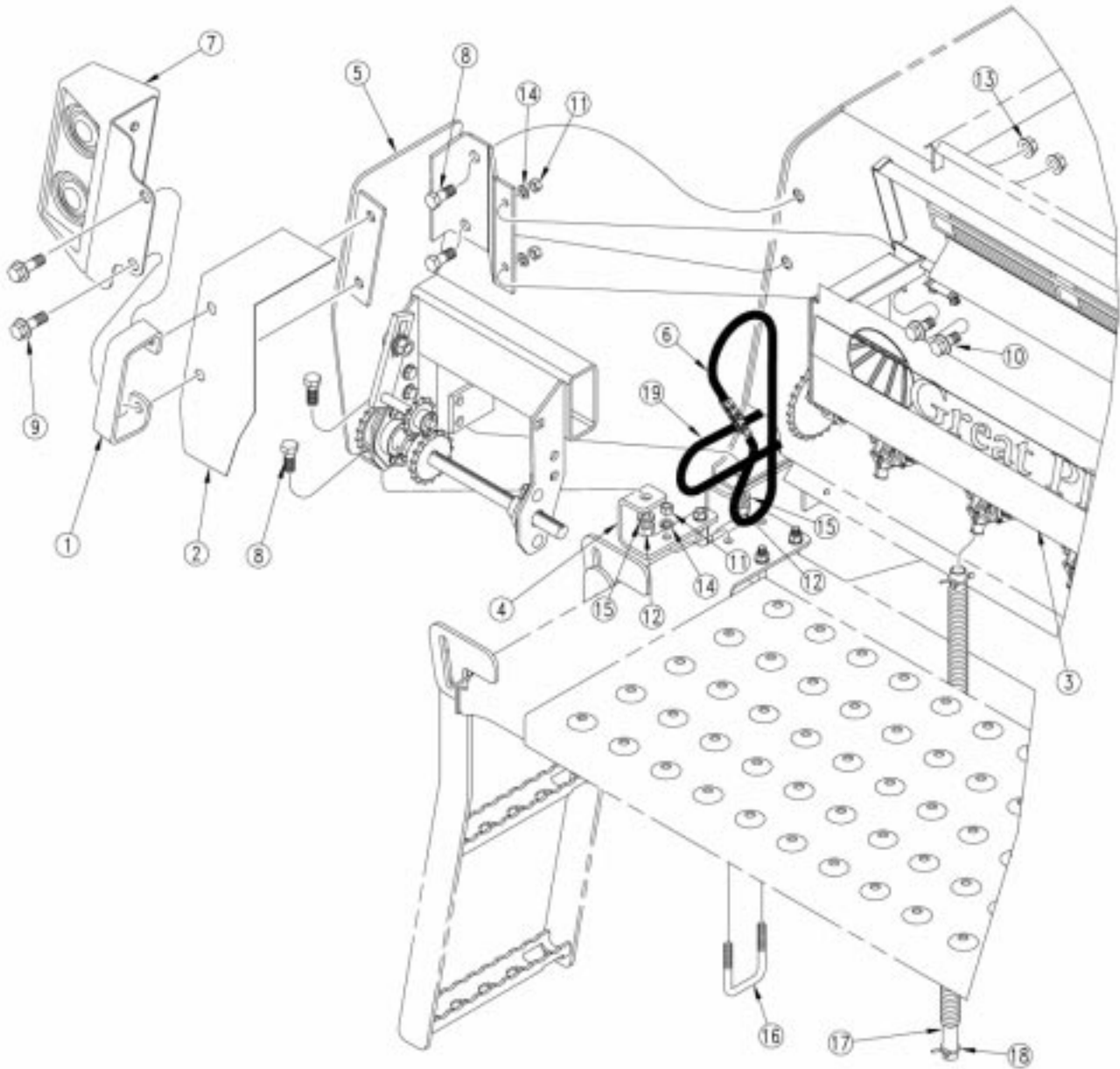

Small Seeds Box Components

Ref.	Part No.	Part Description	Comments
1.	119-190D	HANDLE	
2.	123-491D	HANDLE MOUNT LH CHAIN GUARD	SHOWN
	123-492D	HANDLE MOUNT RH CHAIN GUARD	
3.	123-803L	3PT 15'-7.5SML SD BOX ASSY LH	SHOWN
	123-804L	3PT 15'-7.5SML SD BOX ASSY RH	
4.	133-061D	3PT-P SML SDS MOUNT CHANNEL LH	SHOWN
	133-062D	3PT-P SML SDS MOUNT CHANNEL RH	
5.	133-175K	3PT-P SMLS DS LH MOUNT&DRIVE	
6.	136-093D	CHAIN RL #40 60 PITCHES	
7.	175-177S	LIGHT AND MOUNT SUB ASY LH	SHOWN
	175-178S	LIGHT AND MOUNT SUB ASY RH	
8.	802-034C	HHCS 1/2-13X1 1/4 GR5	
9.	802-203C	HFSS 1/2-13X1 1/2 GR5	
10.	802-388C	HFS 3/8-16X1 GR5	
11.	803-014C	NUT HEX 3/8-16 PLT	
12.	803-020C	NUT HEX 1/2-13 PLT	
13.	803-169C	NUT HEX FLG. LOCK 1/2-13 PLT.	
14.	804-013C	WASHER LOCK SPRING 3/8 PLT	
15.	804-015C	WASHER LOCK SPRING 1/2 PLT	
16.	806-166C	U-BOLT 3/8-16 X 2 1/32 X 3	
17.	816-358C	SGS HOSE 122 RIBS	
18.	800-321C	HOSE CLAMP NO.12 3/4 ID	
19.	136-152D	CHAIN RL #40 96 PITCHES	

Legend: ● = 1st revision; ● = 2nd revision; ● = 3rd revision; ● = use up existing stock; ⊗ = not interchangeable; ⊗ ① ● = for example: revision 2 is not interchangeable w/revision 1

Small Seeds Drive

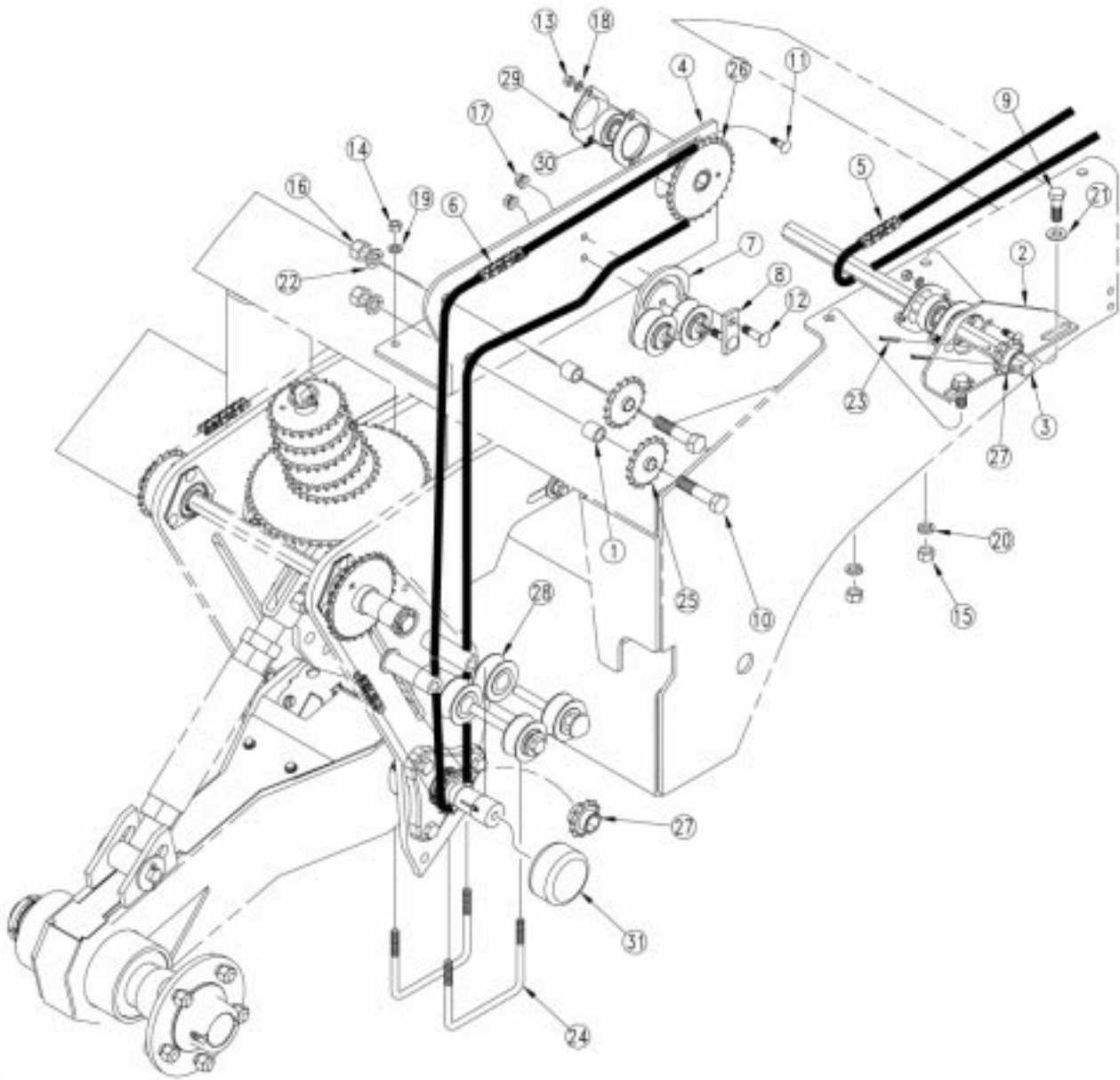

Small Seeds Drive

Ref.	Part No.	Part Description	Comments
1.	116-240D	MB IDLER SPACER	
2.	123-517D	REAR DRIVE BRG MOUNT PLATE LH	SHOWN
	123-518D	REAR DRIVE BRG MOUNT PLATE RH	
3.	133-057D	3PT-P SML SDS JACK SHAFT	
4.	133-058D	3PT-P SML SDS JK SFT MOUNT LH	SHOWN
	133-059D	3PT-P SML SDS JK SFT MOUNT RH	
5.	136-152D	CHAIN RL #40 96 PITCHES	
6.	136-188D	CHAIN RL #40 218 PITCHES W/CON	
7.	402-140S	DOUBLE SPOOL IDLER ASSY	
8.	402-242D	IDLER BOLT PLATE	
9.	802-091C	HHCS 1/2-13X1 1/2 GR5	
10.	802-281C	HHCS 5/8-11X2 3/4 GR5	
11.	802-282C	RHSNB 5/16-18X1 GR5	
12.	802-453C	RHSNB 3/8-16X1 1/2 GR5	
13.	803-008C	NUT HEX 5/16-18 PLT	
14.	803-014C	NUT HEX 3/8-16 PLT	
15.	803-020C	NUT HEX 1/2-13 PLT	
16.	803-021C	NUT HEX 5/8-11 PLT	
17.	803-209C	NUT FLANGE LOCK 3/8-16 PLT	
18.	804-009C	WASHER LOCK SPRING 5/16 PLT	
19.	804-013C	WASHER LOCK SPRING 3/8 PLT	
20.	804-015C	WASHER LOCK SPRING 1/2 PLT	
21.	804-016C	WASHER FLAT 1/2 SAE PLT	
22.	804-022C	WASHER LOCK SPRING 5/8 PLT	
23.	805-024C	PIN ROLL 3/16X 1 1/2 PLT	
24.	806-165C	U-BOLT 3/8-16 X 5 1/32 X 4 1/4	
25.	808-046C	SPKT 40A17 IDLER	
26.	808-168C	SPKT 40B29 X 7/8 HEX BORE & SS	
27.	808-219C	SPKT 40C12 X 7/8 HEX BORE	
28.	817-406C	IDLER 1 PC 2.38X1.01X1.062	
29.	822-032C	FLANGETTE 52 MST	
30.	822-119C	BRG.7/8HEX BR 52MM SPHRICAL OD	
31.	890-673C	ACREMETER 15-P 9.5LX15 383 REV	

Legend: ● = 1st revision; ● = 2nd revision; ● = 3rd revision; ● = use up existing stock; ⊗ = not interchangeable; ⊗ ① ● = for example: revision 2 is not interchangeable w/revision 1

Small Seeds 10 Series Seed Tube

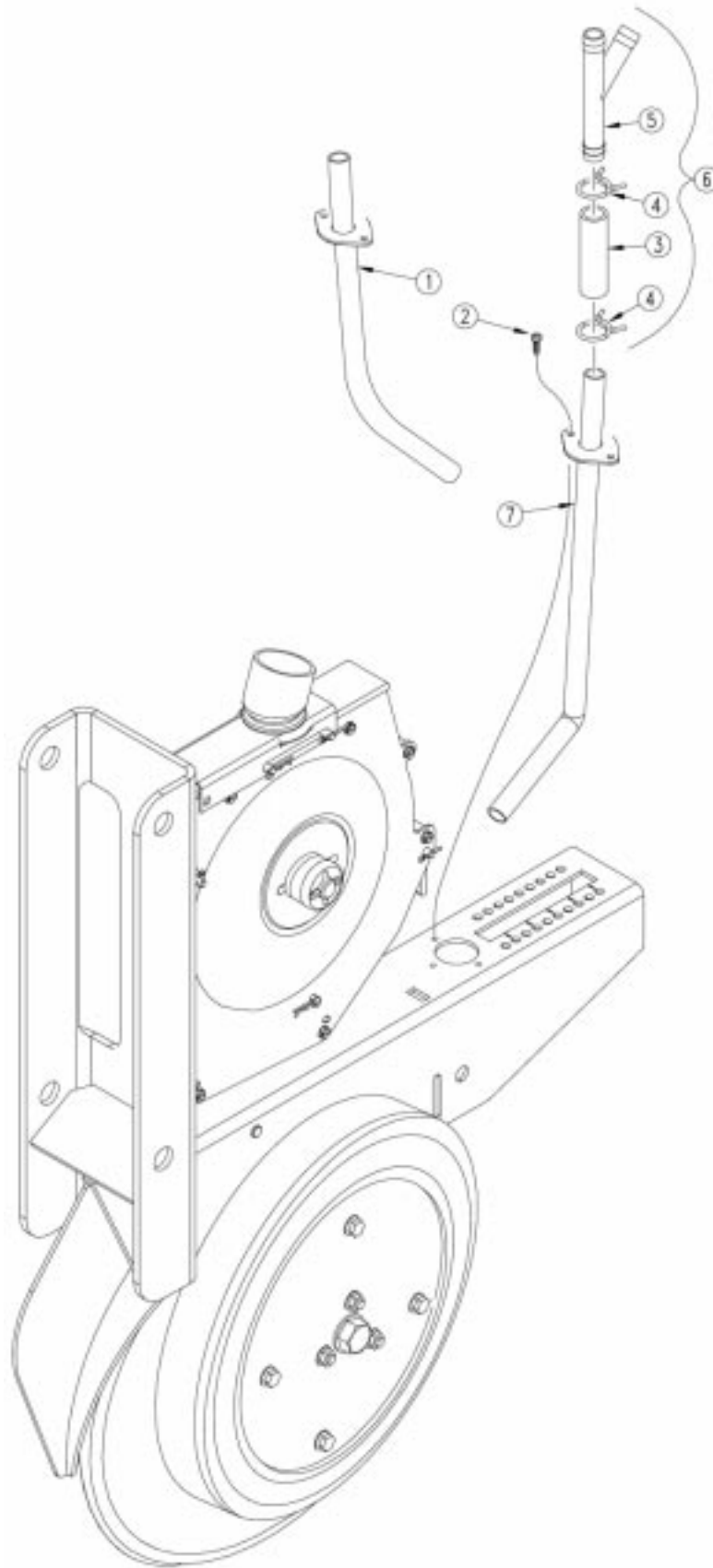

19637

Small Seeds 10 Series Seed Tube

Ref.	Part No.	Part Description	Comments
1.	133-193H	10 SERIES P SMLS DS TUBE W LDMNT	
2.	801-002C	SCREW HEX SLT10-16X3/8P.THD CT	
3.	133-064D	Y-TUBE CONNECTOR HOSE	
4.	800-029C	CLAMP HOSE GRASS SEED	
5.	817-481C	HOSE BARB Y-5/8"X5/8"X5/8	
6.	133-192V	SMLS DS WITH MICROBAND Y-TUBE	Only with MICROBAND option
7.	116-220H	10 SERIES INSECTICIDE TUBE	

Legend: ● = 1st revision; ● = 2nd revision; ● = 3rd revision; ● = use up existing stock; ⊗ = not interchangeable; ⊗ ① ● = for example: revision 2 is not interchangeable w/revision 1

Small Seeds 20 Series Seed Tube

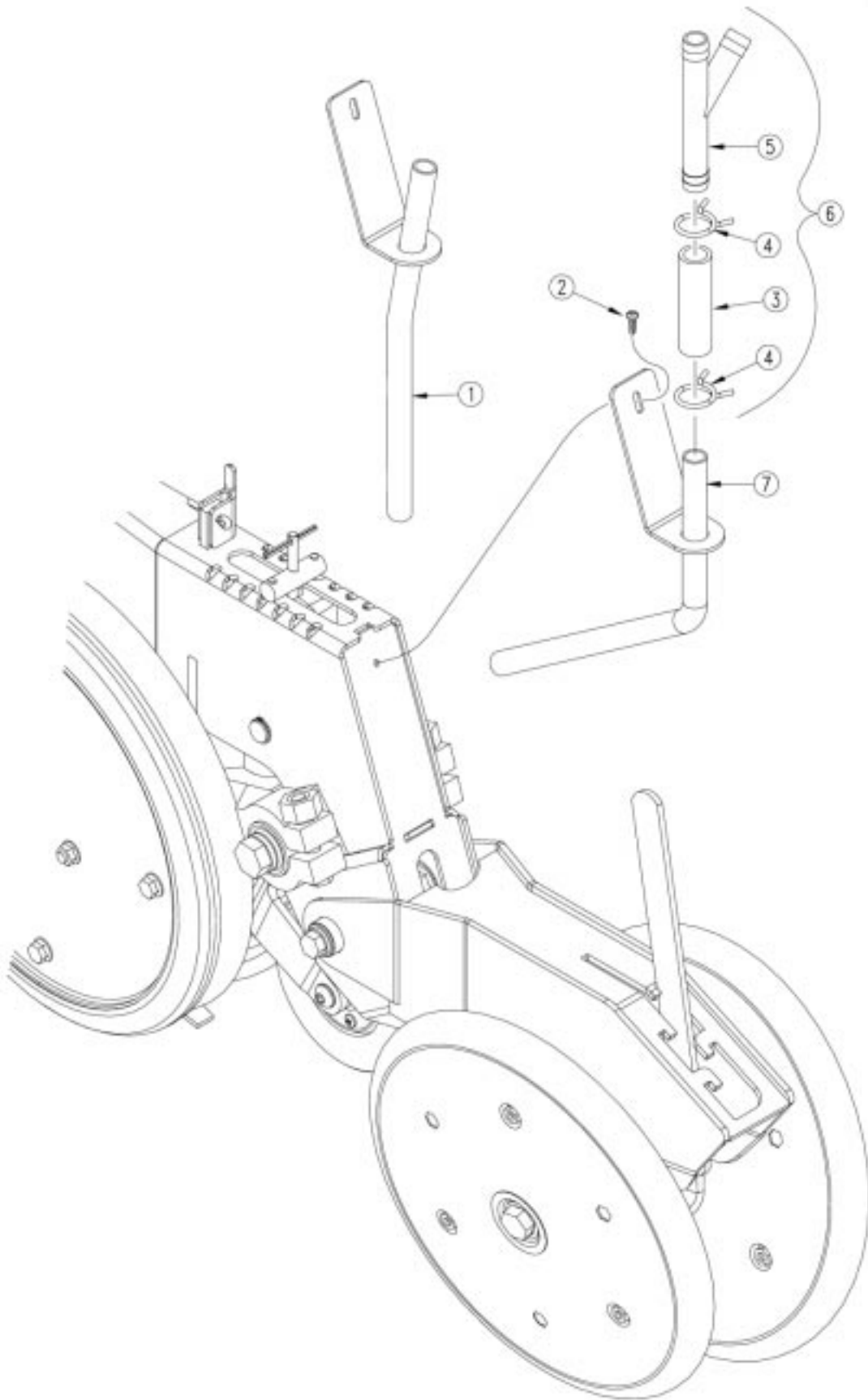

19636

Small Seeds 20 Series Seed Tube

Ref.	Part No.	Part Description	Comments
1.	133-188H	20 SERIES SMLS DS TUBE WELDMNT	
2.	801-002C	SCREW HEX SLT10-16X3/8P.THD CT	
3.	133-064D	Y-TUBE CONNECTOR HOSE	
4.	800-029C	CLAMP HOSE GRASS SEED	
5.	817-481C	HOSE BARB Y-5/8"X5/8"X5/8	
6.	133-192V	SMLS DS WITH MICROBAND Y-TUBE	Only with MICROBAND option
7.	116-221H	20 SERIES INSECTICIDE TUBE	

Legend: ● = 1st revision; ● = 2nd revision; ● = 3rd revision; ● = use up existing stock; ⊗ = not interchangeable; ⊗ ① ● = for example: revision 2 is not interchangeable w/revision 1

Small Seeds Decal Placement

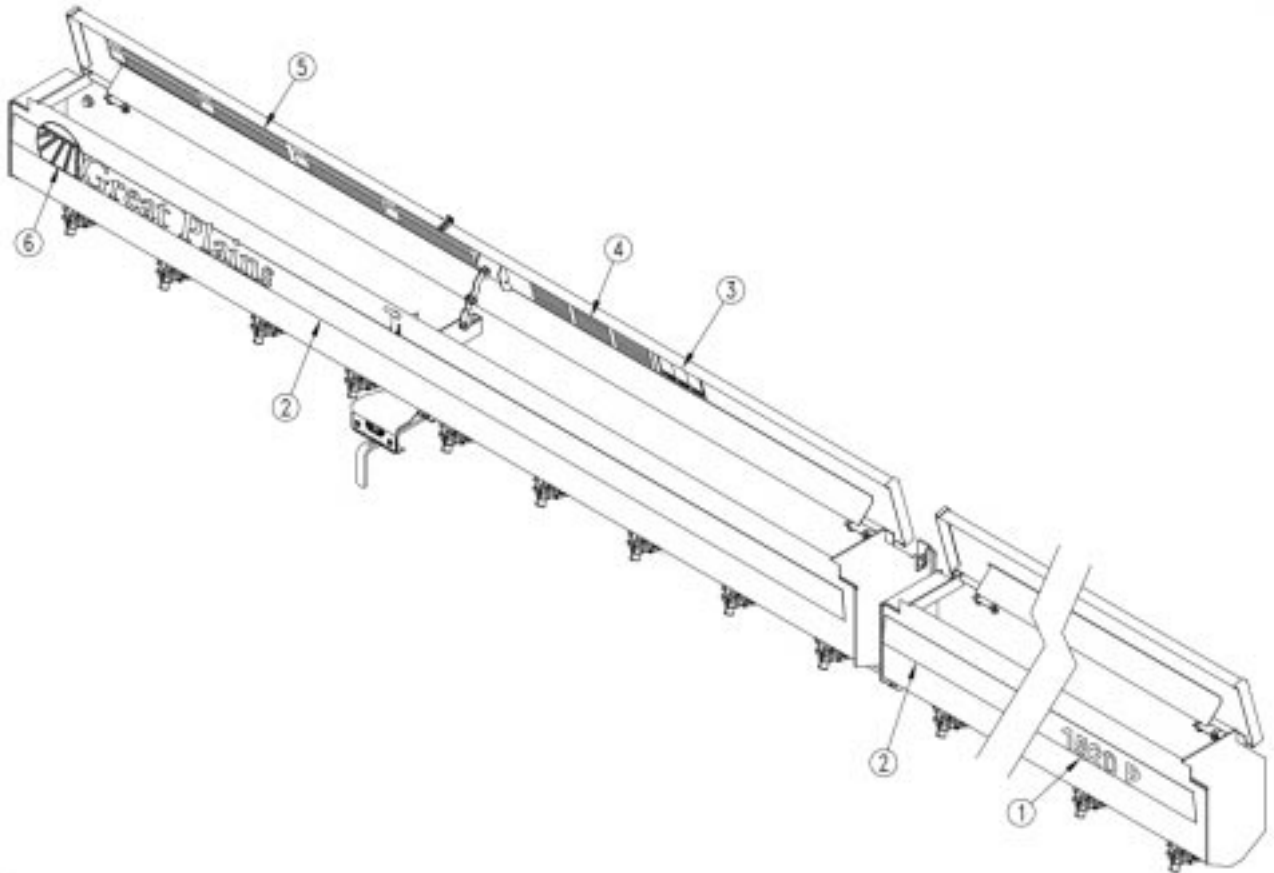

Small Seeds Decal Placement

Ref.	Part No.	Part Description	Comments
1.	838-127C	DECAL 1520 P	
	838-126C	DECAL 1510 P	
2.	838-160C	DECAL 3 COLOR STRIPE 2.50 WIDE	
3.	838-467C	DECAL SMALL SEEDS DANGER	
4.	818-207C	DECAL-GRSSDR SD RATE ADJ INST	
5.	818-245C	GRASS SEEDER SEED RATE	
6.	838-161C	DECAL LOGO&GP F/STRIPE 4 X 24	

Legend: ● = 1st revision; ● = 2nd revision; ● = 3rd revision; ● = use up existing stock; ⊗ = not interchangeable; ⊗ ① ● = for example: revision 2 is not interchangeable w/revision 1

Veris Drive To Frame

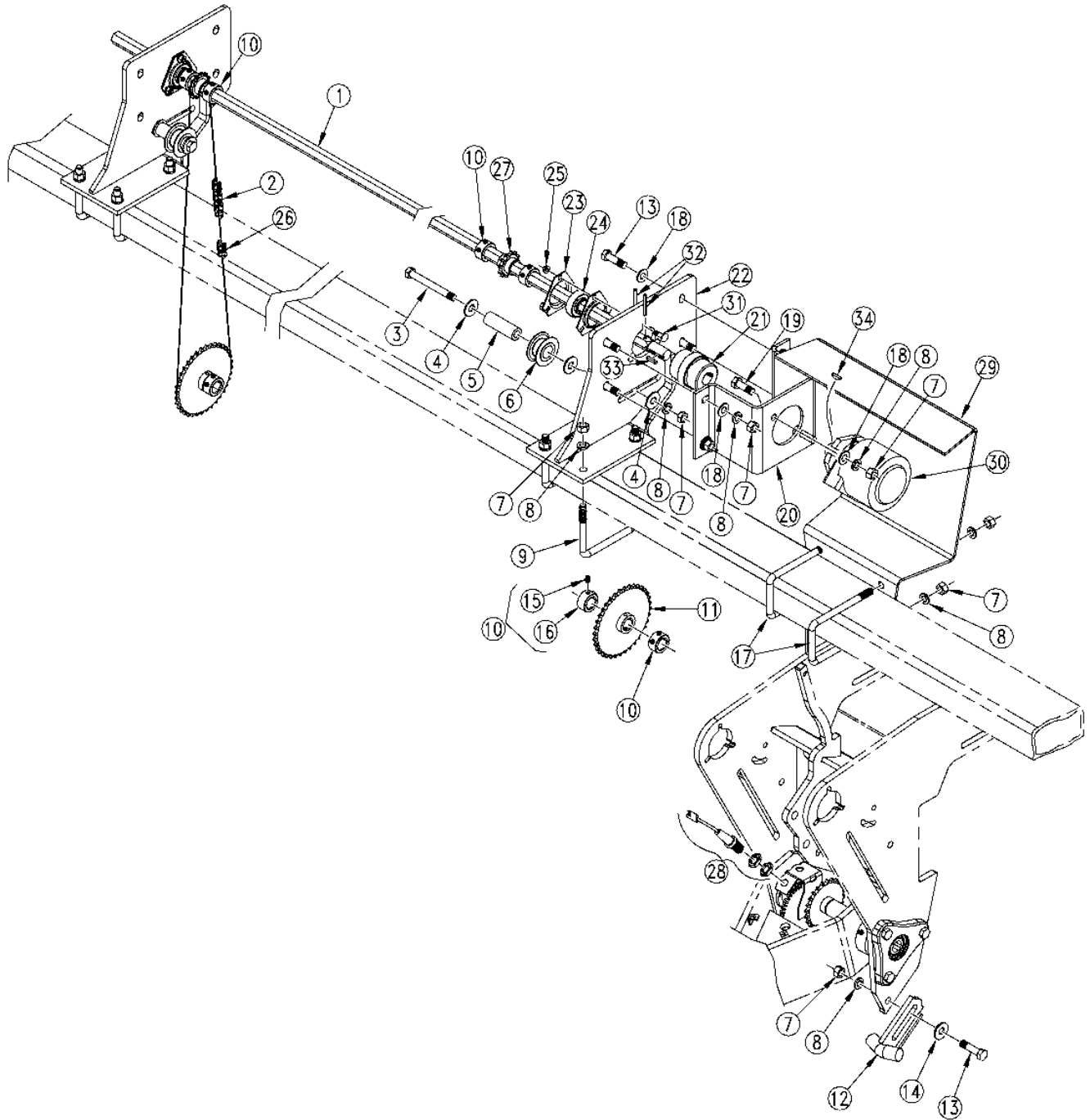

Veris Drive To Frame

Ref.	Part No.	Part Description	Comments
1.	120-320D	SHAFT 7/8 HEX VARI DRIVE 15P	
2.	136-157D	CHAIN RL #40 135 PITCHES	
3.	802-672C	HHCS 1/2-13X4 1/2 GR5 SPTH	
4.	804-113C	WASHER FLAT 1/2 USS HARD PLT	
5.	120-293D	TUBE RND DOM. 1 OD X 7/32WX3.0	
6.	817-406C	IDLER 1 PC 2.38X1.01X1.062	
7.	803-020C	NUT HEX 1/2-13 PLT	
8.	804-015C	WASHER LOCK SPRING 1/2 PLT	
9.	806-159C	U-BOLT 1/2-13 X 5 1/32 X 4 1/2	
10.	402-025S	LOCK COLLAR, 7/8 HEX W/ SET SC	
11.	808-251C	SPKT 40C36 X 7/8 HEX BORE	
12.	120-211H	GAUGE WHEEL BRAKE	
13.	802-082C	HHCS 1/2-13X1 3/4 GR5	
14.	804-017C	WASHER FLAT 1/2 USS PLT	
15.	801-035C	SCREW SET 5/16-18 SKT KP X 3/8	
16.	402-058D	COLLAR LOCK 7/8 HEX	
17.	806-122C	U-BOLT 1/2-13 X 3 1/32 X 6	
18.	804-016C	WASHER FLAT 1/2 SAE PLT	
19.	802-091C	HHCS 1/2-13X1 1/2 GR5	
20.	120-319D	MOTOR ADAPTOR SAE A 2 BOLT	
21.	802-082C	HHCS 1/2-13X1 3/4 GR5	
22.	826-350C	CONFLEX COUPLING #3R 1BX7/8 B	
23.	120-294H	DRIVE BRACKET	
24.	822-175C	FLANGETTE 52 3-BOLT PLT	
25.	822-119C	BRG.7/8HEX BR 52MM SPHRICAL OD	
26.	803-177C	NUT HEX LOCK 5/16-18 FLG.	
27.	809-070C	CHAIN CONNECTOR LINK #40 OFFST	
28.	808-219C	SPKT 40C12 X 7/8 HEX BORE	
29.	833-200C	DJ MAGNETIC PICKUP	
30.	VER-19517	VERIS CONTROL MODULE MT 15/24	
31.	VER-18468	VERIS MOTOR HYD 5.4 CIR W/ENC	
32.	802-282C	RHSNB 5/16-18X1 GR5	
33.	805-180C	PIN ROLL 1/4 X 1 1/2 LG PLT	
34.	800-269C	CABLE TIE 33LG	
35.	VER-20317	KEY WOODRUFF #808 1/4X1	

Legend: ● = 1st revision; ● = 2nd revision; ● = 3rd revision; ● = use up existing stock; ⊗ = not interchangeable; ⊗ ① ● = for example: revision 2 is not interchangeable w/revision 1

Veris Drive Components

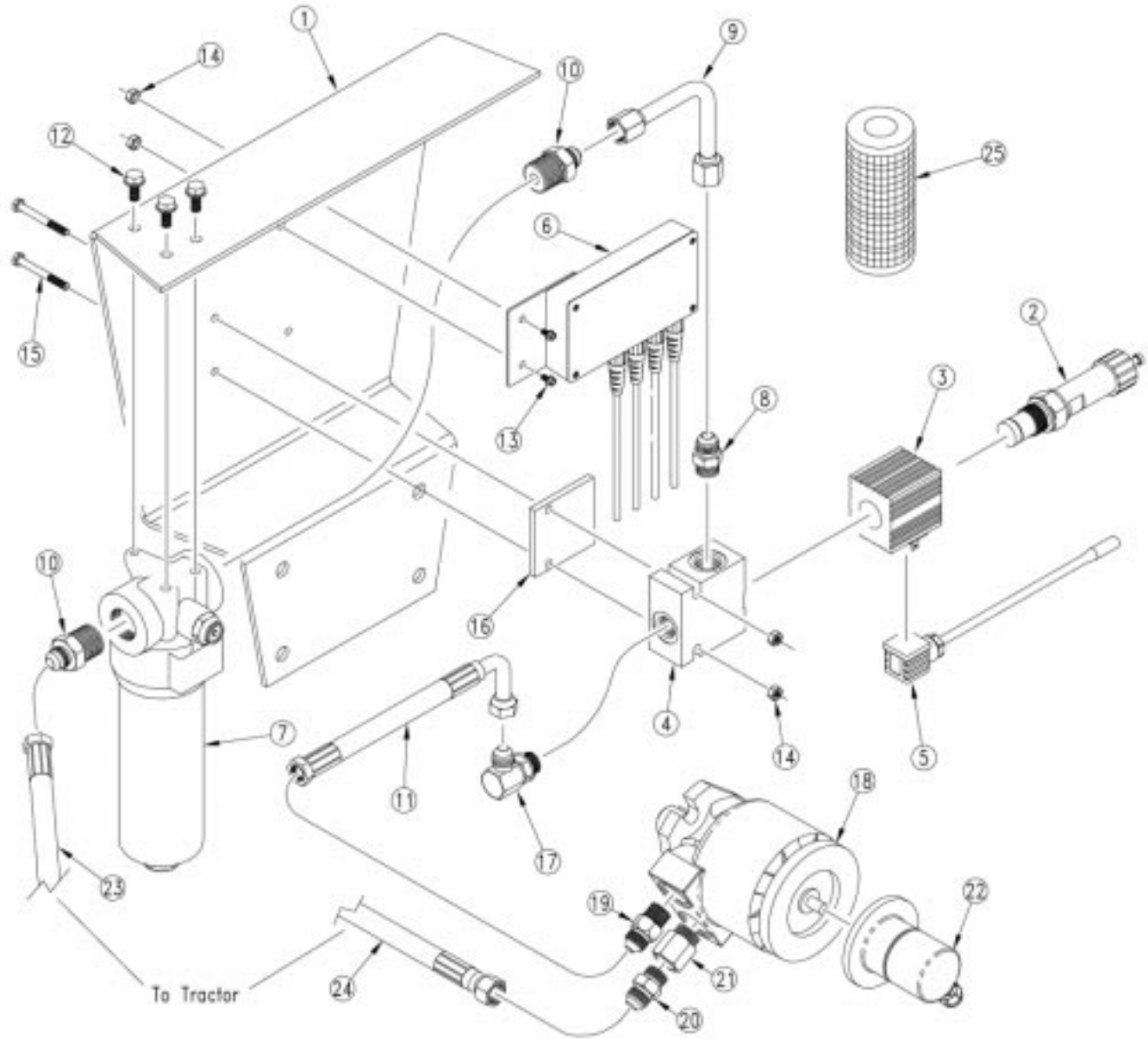

Veris Drive Components

Ref.	Part No.	Part Description	Comments
1.	VER-19517	VERIS CONTROL MODULE MT 15/24	
2.	VER-19798	VERIS VLV PROPORTIONAL CARTRID	
3.	VER-19799	VERIS COIL 12V WATERMAN CARTRI	
4.	VER-19800	VERIS VLV BODY SAE-12-2X SAE-8	
5.	VER-18375	VERIS SOLENOID CABLE	
6.	VER-21568	VERIS EXT. CONTROL	10/1/2002+
	VER-18360	VERIS CONTROLLER ASM	9/30/2002-
7.	VER-18574	VERIS FILTER 3000 PSI	
8.	811-088C	AD 3/4MORB 3/4MJIC	
9.	VER-5211	VERIS HYD LINE STL	
10.	811-205C	AD 3/4MJIC 1 1/16MORB	
11.	VER-19620	VERIS HOSE8M3K-8FJX90S-8FJX 28	
12.	VER-18548	BOLT FLG SERR 8.8 M8-1.25X16MM	
13.	802-004C	HHCS 1/4-20X3/4 GR5	
14.	803-088C	NUT HEX LOCK 1/4-20 FLG	
15.	802-551C	HHCS 1/4-20X2 1/4 GR5	
16.	VER-20129	VERIS CONTRLLER VLV BODY SPACR	
17.	811-063C	EL 3/4MJIC 3/4MORB	
18.	VER-18468	VERIS MOTOR HYD 5.4 CIR W/ENC	
19.	811-192C	AD 3/4MJIC 7/8MORB	
20.	VER-19554	VERIS VLV IN-LINE CHECK	
21.	811-564C	AD 3/4FORB 7/8MORB	
22.	VER-18382	VERIS ENCODER W/ CABLE	
23.	VER-18577	VERIS HOSE8M3K-8KJX90S-8MB 312	Used with no-till drills
	VER-19625	VERIS HOSE8M3K-8FJX90S-8MB 126	Used with mounted drills
24.	VER-19621	VERIS HOSE8M3K-8FJX90S-8MB 290	Used with no-till drills
	VER-19626	VERIS HOSE8M3K-8FJX90S-8MB 104	Used with mounted drills
25.	VER-19856	FILTER ELEMENT PALL 6 MICRON	

Veris Drive Controller

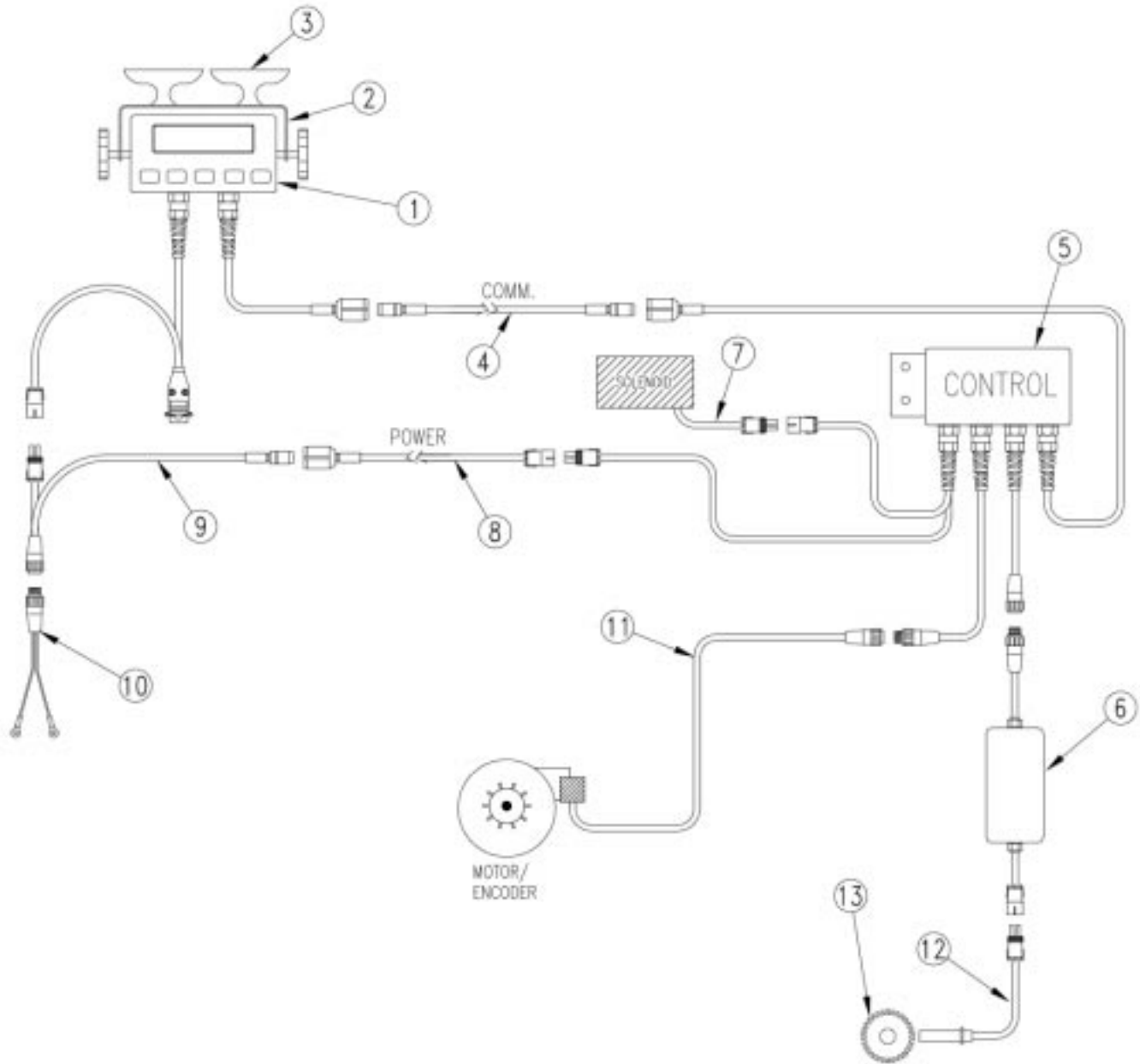

Veris Drive Controller

Ref.	Part No.	Part Description	Comments
1.	VER-21567	VERIS USER INTERFACE ASM	10/1/2002+
	VER-18363	VERIS USER INTERFACE ASM	9/30/2002-
2.	VER-19516	VERIS MOUNT	
3.	VER-19579	VERIS SUCTION CUP	
4.	VER-18377	VERIS COMMUNICATION CABLE 26FT	Used with no-till drills
	VER-19679	VERIS COMMUNICATION CABLE-10.5F	Used with mounted drills
5.	VER-18360	VERIS CONTROLLER ASM	
6.	VER-19677	VERIS RELUCTANC SNSR ADAPTR MOD	
7.	VER-18375	VERIS SOLENOID CABLE	
8.	VER-18376	VERIS POWER SOURCE CABLE 26FT	Used with no-till drills
	VER-19683	VERIS POWER SOURCE CABLE-10.5F	Used with mounted drills
9.	VER-19676	VERIS POWER PORT ADAPTER	
10.	VER-19729	POWER PORT ADAPTER-HYD DRIVE---GP BREAKOUT	
11.	VER-18382	VERIS ENCODER W/ CABLE	
12.	833-200C	DJ MAGNETIC PICKUP	
13.	120-309D	SENSOR DISC, 42T 5.3 DIA PLTD	