

GERINGHOFF

Operating instructions

Rota – Disc*

Corn header

Carl Geringhoff – Vertriebsgesellschaft mbH & Co. KG
Gersteinstraße 18, D – 59227 Ahlen
Tel. ++49-2382-9814-0, Fax ++49-2382-981440

E-Mail: info@geringhoff.de Internet: www.geringhoff.de

General

Certificate of conformity EC	02 / 000
General safety arrangements	01 / 020
Introduction	01 / 000
To the customer	01 / 010
Warning label (pictograms)	01 / 030

Corn header

Contrate gearing speed change	09 / 600
Couplers between the stripping plates	09 / 640
Corn header to mount	09 / 120
Corn header drive	09 / 160
Corn header to unpack	09 / 000
Cross belt auger / feeding	09 / 720
Cut-off block	10 / 210
Divider noses to mount	09 / 320
Drive coupler folding corn headers	09 / 280
Gathering chains	09 / 520
Gearing and oil control	09 / 560
Hydraulic connections to mount	09 / 200
Hydraulic function of folding corn headers	09 / 240
Mounting arrangements on combine	09 / 080
Operation and function of monitor	09 / 440
Overload protections and sliding clutches	09 / 800
Stripping plate adjustment	09 / 480
Trial run	09 / 680
Weights	09 / 040

Rota Disc* Corn header

Knife disk shaft	10 / 100
Stripping rotors	10 / 200
Stubble cutter / stripper	10 / 000

Maintenance and Care

Maintenance and care	10 / 300
----------------------	----------

Help in case of malfunctions

Cross belt auger	10 / 915
Drive	10 / 905
Hydraulics	10 / 900
Stripping unit	10 / 910

Special equipment

Corn ear saver	35 / 050
Change speed gear	35 / 010
Change speed gear	35 / 005
Lodged maize augers	
Sunflower harvester	35 / 000

Special tools

Chain tension tool	36 / 000
Starting torque for screws	36 / 100
Puller for rotor bearing	36 / 000

Wiring diagrams etc.

Wiring diagram combine lighting	36 / 500
Wiring diagram hydraulics folding headers	36 / 300

Introduction

These operating instructions describe the most essential working steps for a safe handling and use of the Geringhoff products.

Read these instructions and observe the safety notes.

A regular maintenance and care will help to keep the value of the product and to ensure a trouble-free use over many years to your benefit.

Tell us about your experience made with the machine to enable us to put it into practice. The partnership with our customers is very important to us and will contribute to our common success.

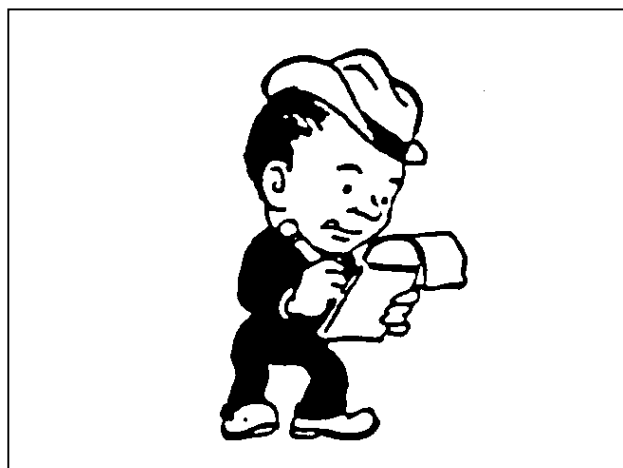

We thank you for the confidence placed in us on the purchase of a Geringhoff product.

Hereunder you'll find some important information for the use of these operating instructions:

- When using the operating instructions, we recommend using also the spare part catalogue for gaining an in-depth understanding of essential details.
- Note the most important data of your machine in the fields provided. That makes it easier to you answering the questions of your supplier.

Machine no.: _____

Machine type.: _____

Year of construction: _____

Row distance: _____

Working width/ Number of row units: _____

Combine type.: _____

- The series no. is on the typeplate left on the supporting frame.
- The operating instructions contain the international standard SI-measures.
- Right and left means always towards travel and/or working direction.
- If you are in need for spare parts, keep the required data available and get in touch with your dealer.
- Do only use **original Geringhoff spare parts**.
- Send the completed consignment note directly to the manufacturer. This information is very important for potential guarantee claims. Failing which, these potential claims cannot be handled.
- Do not make any modifications on important, load-bearing and safety-relevant elements. The manufacturer does not assume any guarantee for damages resultant therefrom.

To prevent accidents, follow strictly these operating instructions and warning notes on the machine.

Before starting the machine, check it for operational dependability and traffic safety!

Apart from these operating instructions, follow also the current safety instructions!

The warning signs and labels give important notes for the safe operation of the machine and serve to your and the health of others!

Prior to starting the works, make yourself familiar with all operating elements and functions.

Check the driving characteristics, steering and braking behaviour.

No riders unless sitting on the provided places.

When working on the machine, the provided supporting devices must be used.

Admissible axle loads and total weight must absolutely be observed.

Before the start-up, all guards and maintenance holes to close.

Whilst the machine is running, keep off the dangerous area.

Maintenance and repairing works to be performed only with Diesel motor cut off.

On public roads the legal provisions to observe.

All machines have a valid ABE or EBE governing the road transport licensing regulations.

If required, additional headlights for the road transport to mount.
(see road transport licensing regulations)

The instructions of the combine manufacturer for the operation with headers to follow.



ISO 11684

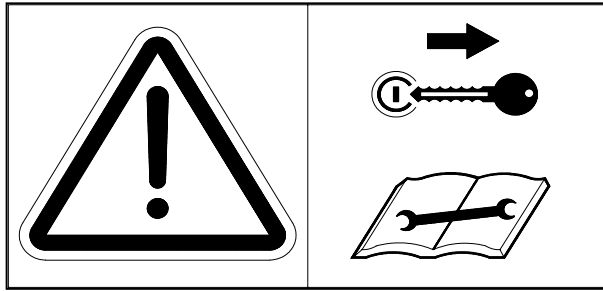

Prior to performing maintenance and repairing works, the motor to turn off and the key to withdraw!

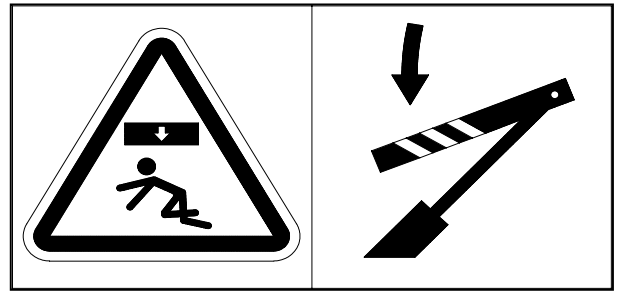

It's only allowed to go into the dangerous zone when the lifting cylinder safety is put in!

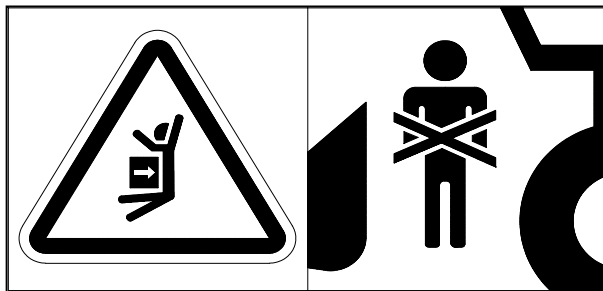

Keep off the dangerous zone between header and machine!

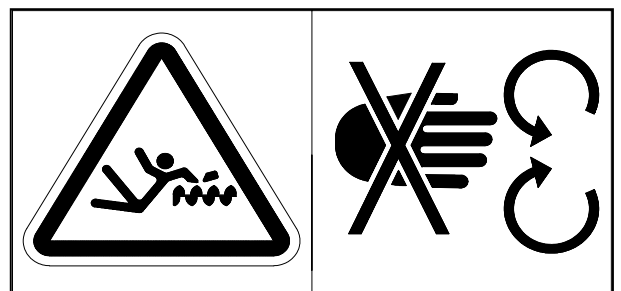

During the operation guards must not be opened or removed!

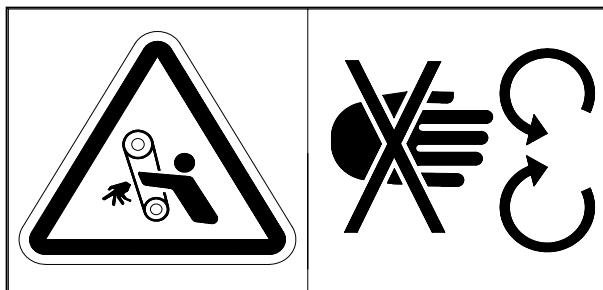

Whilst motor is running, guards never to open or remove!

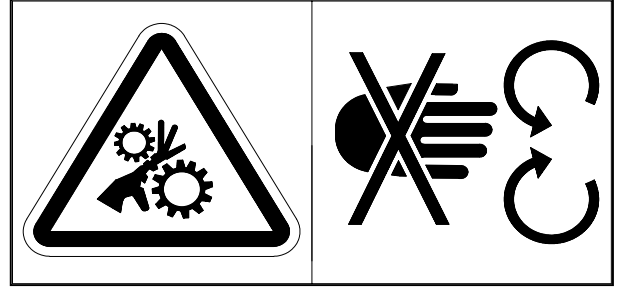

Whilst the motor is running, guards must not be opened or removed!

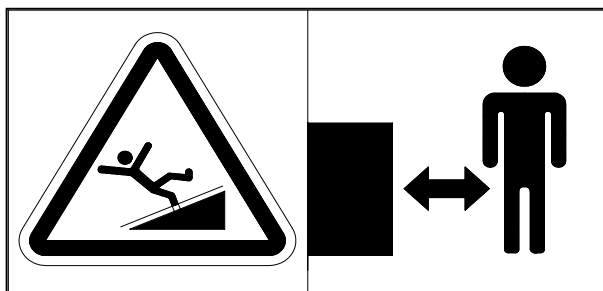

Keep a sufficient safety distance to the header. Prior to maintenance works or clearing of cloggings header to switch off, motor to stop and key to withdraw!

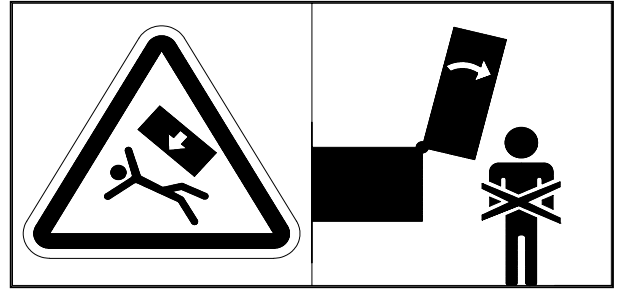

Never go into the slewing range of the machine!

02 / 000

EC Declaration of Conformity
according to Directive 89/392/EEC



We

**Carl Geringhoff
Vertriebsgesellschaft mbH & Co.
Gersteinstraße 18
D-59227 Ahlen**

declare under our sole responsibility, that the product

Geringhoff Maize Snapperhead system ROTA DISC*
of the models
RD300, RD400, RD500, RD600, RD700B, RD800B, RD900B, RD1200B, RD1800

to which this declaration relates corresponds to the relevant
basic safety and health requirements of
the Directive 89/392/EEC.

For the relevant implementation of the safety and health requirements
mentioned in the Directives,
the following standards have been respected:

prEN 632 (June 1994); EN 294 (1992); EN 292-1 (November 1991);
EN 292-2 (November 1991)

Wolfgang Dreuer
Product Manager

Ahlen, 17.03.2000

EC Declaration of Conformity
according to Directive 89/392/EEC



We

**Carl Geringhoff
Vertriebsgesellschaft mbH & Co.
Gersteinstraße 18
D-59227 Ahlen**

declare under our sole responsibility, that the product

Geringhoff Maize Snapperhead system ROTA DISC*
of the models
RD600F, RD800FB, RD900FB, RD1200FB

to which this declaration relates corresponds to the relevant
basic safety and health requirements of
the Directive 89/392/EEC.

For the relevant implementation of the safety and health requirements
mentioned in the Directives,
the following standards have been respected:

prEN 632 (June 1994); EN 294 (1992); EN 292-1 (November 1991);
EN 292-2 (November 1991)

Wolfgang Dreuer
Product Manager

Ahlen, 17.03.2000

EG-Konformitätserklärung

GERINGHOFF

Rota – Disc*

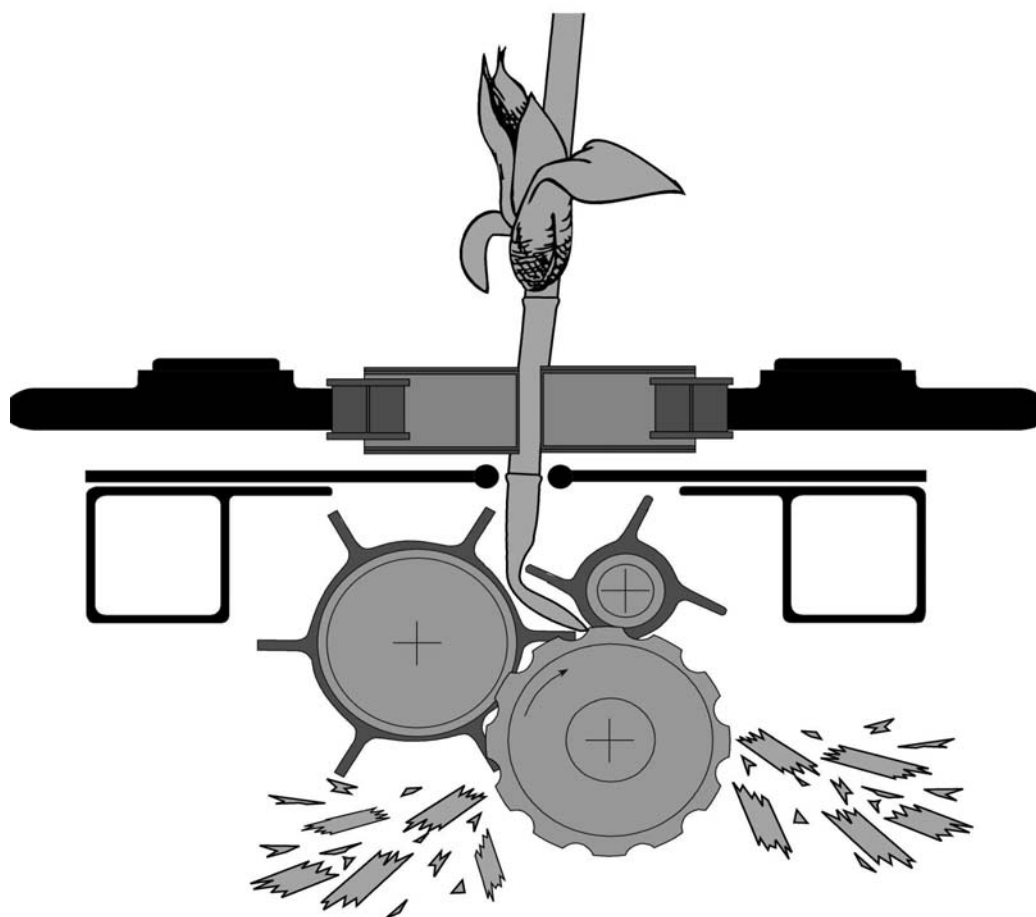

We reserve the right of making modifications for the sake of progress.

Sizes and weights are approximate values and refer each to the standard versions of the different header types.

Due to the great number of header models and combines this list cannot show all the different illustrated variants. For this reason, we hope you will understand the general sense of the wordings, which requires a sufficient basic knowledge of the carrier machine.

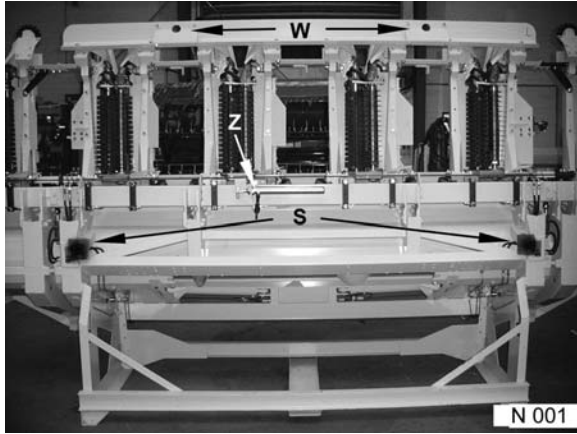

Scope of supply / state at time of supply

Subject to model and type the header can be supplied in horizontal position or upright on a shipping crate. Each consignment is accompanied by a detailed and type-referred packing list.

Packages attached to the header to remove. Check the scope of supply!

Check the supplied row distance!

Ensure the safe standing of the machine!



Remove the shipping crate

Extend the supports (S). Move the hoist to the bottom side of the header.

Suitable chains or belts to attach to the drawbar eyes (W), slightly to lift and hoist slowly to move away from the header.

Header carefully to lower considering the tilting angle.



**Use hoist, which is strong enough!
Do not go into the dangerous zone!
Follow the instructions for hoists!**

Remove screws (B) and shipping crate.

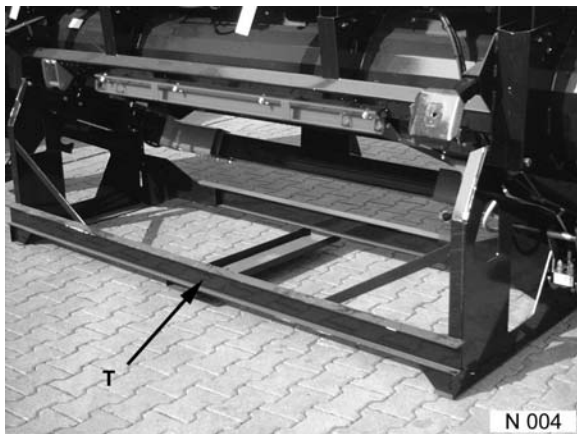
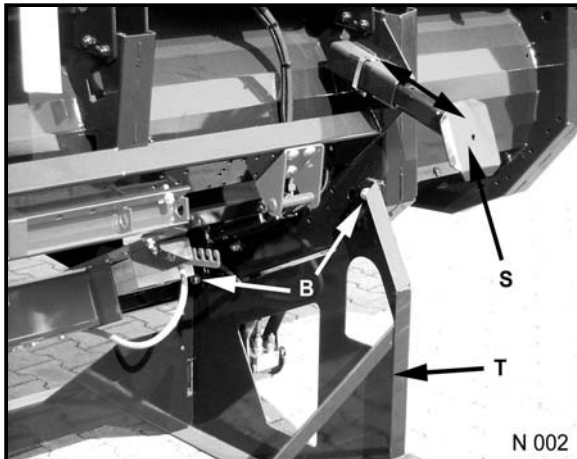

Further use of the trestle

The trestle (T) is recommended to be stored for a later use.

Possible after-season and service works are to be performed easier with the machine standing in upright position.

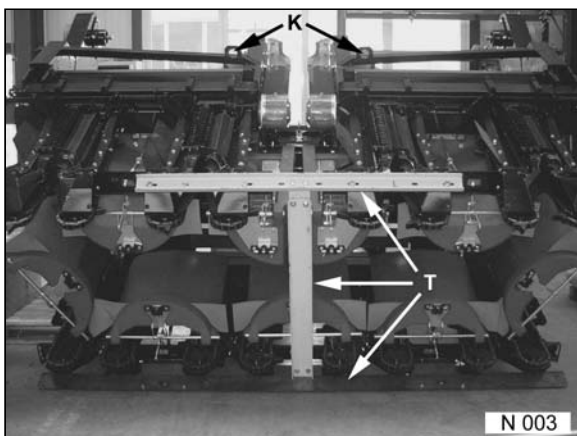

Folding corn headers to lift by crane

Folding headers are possibly supplied without shipping crate (T).

For the transport with hoists only provided eyes (L) and location on the front transport angle (S) to be used. If required, transport protection to remount.

Before mounting the header to the combine, transport protection to remove (S).

Protection to remove only when the header stands on firm ground.

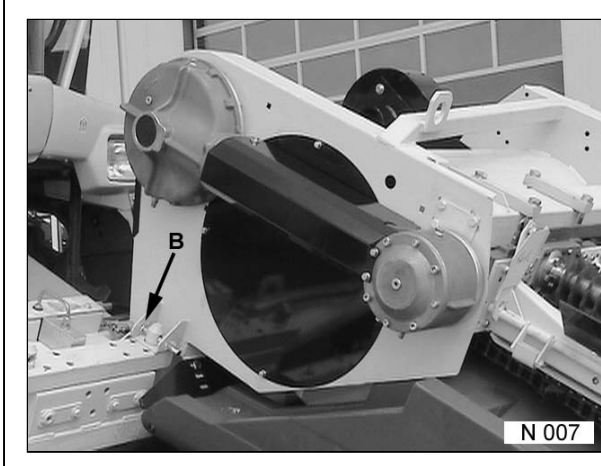

Transport protection folding corn headers

Apart from the transport protection as shown in picture N 003, folding corn headers from 8 rows are fitted with an additional protection (B) on the frame.



Bolts (B) not to remove before definite placing down of the header and removing of the hoist.

When using the hoist again, locking bolt (B) must be put in before.

Corn header	Approximate weight in kg
4-rows	1290
5-rows	1640
6-rows	1975
6-rows (folding)	2250
7-rows (folding)	2400
8-rows	2520
8-rows (folding)	3025
9-rows	2750
9-rows (folding)	3250
12-rows	3650
12-rows (folding)	4150

Take a hoist, which is strong enough

The weight of the different header models to be learnt from the opposite table.

Follow the instructions for the use of hoists!

The exact weight of the different headers is indicated well visible on the typeplate of each machine!



Front protection on gathering channel

The standard front protection (S) on top of the feeding chain and the stripping angles (A) on the gathering channel front are to be dismantled.

The corn header itself is fitted with a special front protection.



When working on the combine, the Diesel motor must be turned off!

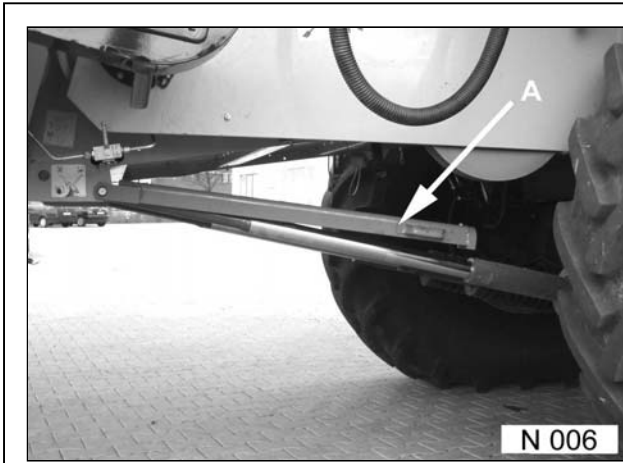

Assembly preparations gathering channel

The feeding chain, its tension and the distance to the channel bottom is to be adjusted according to the instructions of the manufacturer.
(See combine manual)

Prior to the first mounting of the header, the anti-lowering device of the gathering channel to check. Never to perform works on the header without using this device.



On all service works on the mounted header, lowering lock to activate!

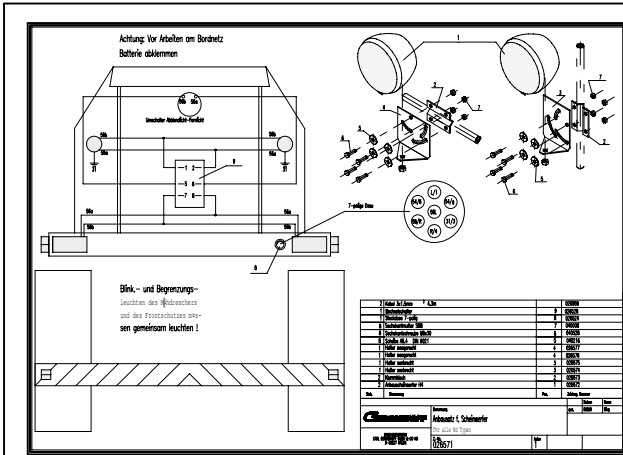

Additional headlights

Some combine models require to mount additional headlights for the road travel, see the scope of supply of the header.

A wiring diagram is enclosed to the headlight set. A position switch must be used for changing between standard and additional headlights!

Instructions of the TÜV-expertise to observe!

General terminal connecting diagram on page 36 / 500

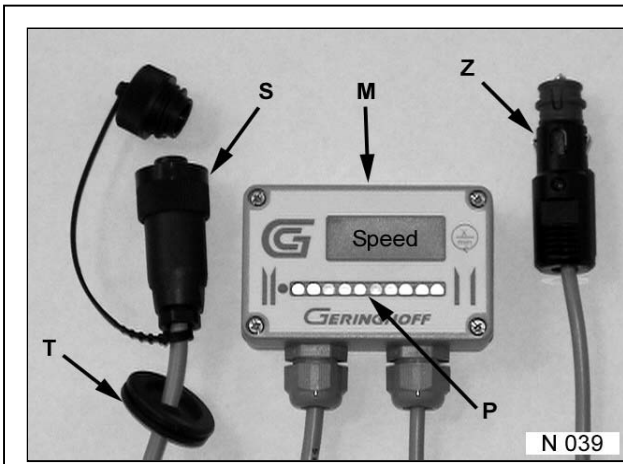

Monitor

Display unit (M) to mount well readable but without visual obstruction on top of the fittings.

The 12 V current is supplied independent of the ignition lock via the plug (Z). (fuse max. 10 Amp.).

Connecting cable (S) right below with seal (T) to lead out of the cabin bottom. Ensure that the cable is long enough outside the cabin.

The monitor reads both the speed of the header and the position of the stripping plates (P) via a changing number of diodes.

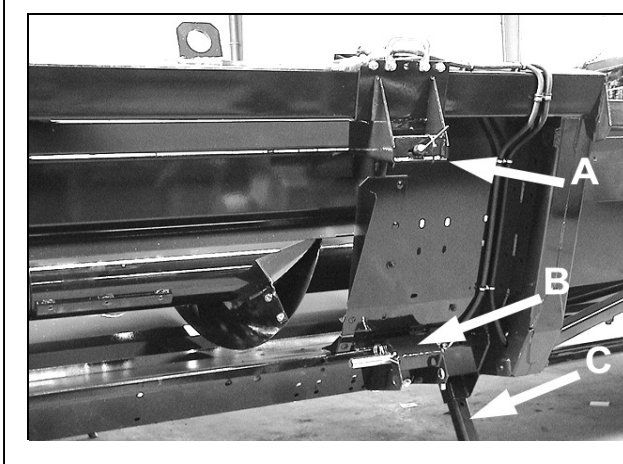

Adaptation to the combine

The corn header is to be placed down on the supports (C). Check the correctness of the adaptation parts. For further information, see spare part catalogue 3061000 from picture table 60/..

Combine to move to the header.

Header with the gathering channel to lift.
Correct seat of the adaptation parts (A) to check.



Persons are not allowed to stay between comb between combine and header during the mounting process.

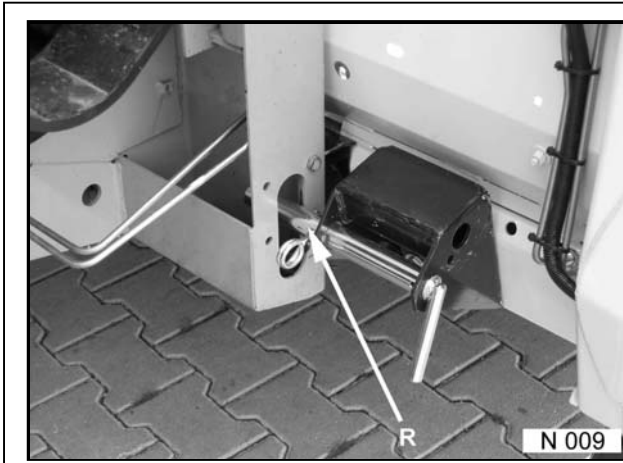

Corn header to lock on gathering channel



**Corn header to secure against unwanted lowering!
Use locking mechanism on the hydraulic cylinders!**

The header (R) to be mounted to the points and devices of the combines as provided.

Corn headers always slowly to lower to the ground to keep unwanted forces away from the locking.

Follow the instructions of the combine manufacturer!

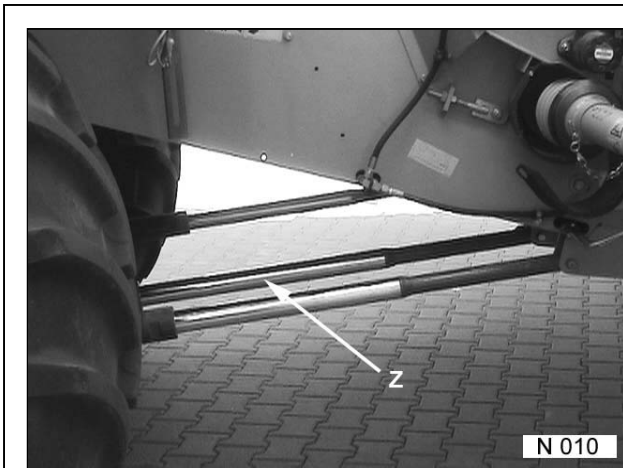

Additional lifting cylinder

Subject to the size and weight of the corn header, one or two additional hydraulic cylinders (Z) may be required.

The combine manufacturer holds the corresponding kits ready.

Subject to the design of the corn header and carrying capacity of the different combines, the steering axle may require using additional weights and the tires being filled with water.

Follow the instructions of the combine manufacturer and TÜV-expertise



Additional counterweights

Subject to the weight of the mounted corn header, additional loading weights may be required for being mounted to the steering axle of the combine.

The dimensions of these additional weights are to be learnt from the road permit, combine manual or TÜV-expertise of the corn header.



The road transport licensing roads must regulations must absolutely be followed.

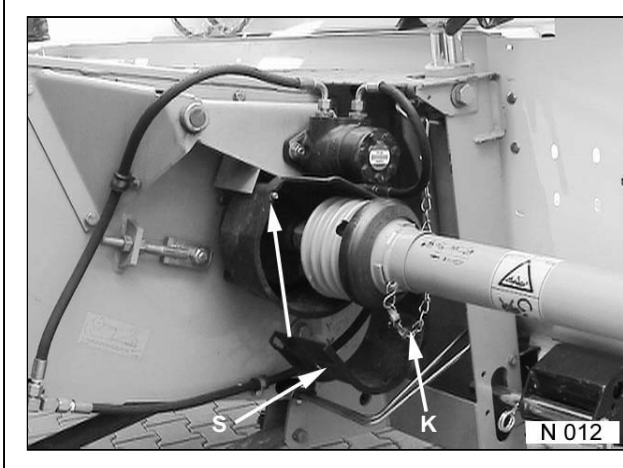

Drive with PTO-shaft

Unfolding corn heads are driven by a simple PTO-shaft on the right side.

Subject to the combine models, they can also be driven on the left side, e.g. machines > 6 rows.

PTO-shaft protection to prevent from turning via chain (K).

If the combine is fitted with a pivoting shield, overlapping to be checked in extended state.



Protective devices (S) to be checked prior to start-up. Do not open or remove them during operation.



Folding headers with PTO-shaft coupler

Check the PTO-shaft between coupler and channel connection for sufficient overlapping. If required, pivoting shield to actuate.



The heel compensation of some models requires to be blocked.

On RD600F / RD800FB e.g. to John Deere series 20... / 22... + WTS / STS / CTS with PTO-shaft coupler, the pivoting shield must be blocked (follow the instructions).

Hillside combines cannot be operated with automatic PTO-shaft coupler.

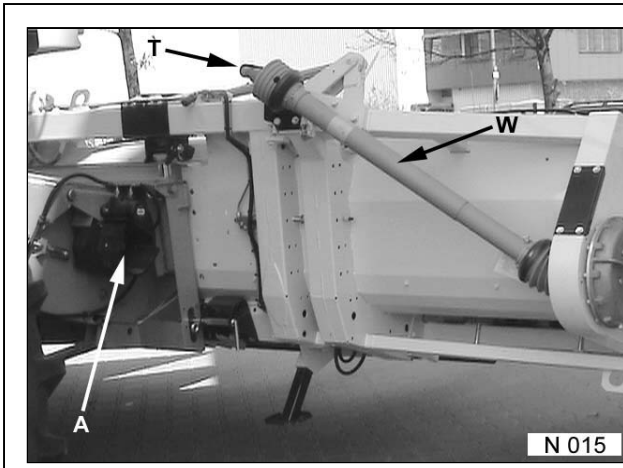

Drive for hillside combines

All hillside combines are directly driven by PTO-shafts (W) to be slipped on by hand.

Certain combine-header combinations require wide angle or even special PTO-shafts.

Instructions absolutely to follow and PTO-shaft design to consider.



Prior to start up, check pivoting range and PTO-shaft length. Check for sufficient overlapping.

The fastening (T) of the PTO-shaft is for transport.

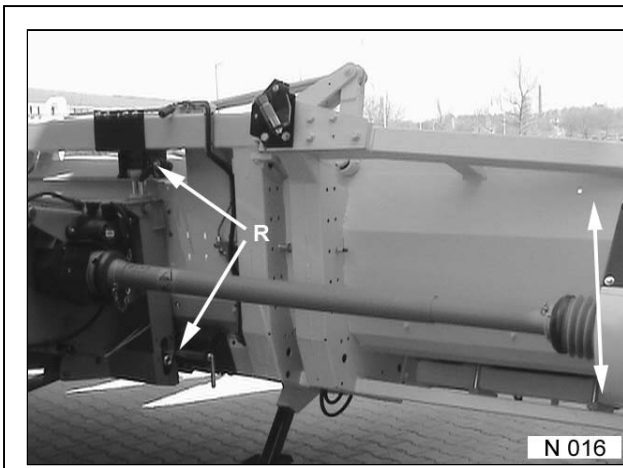

Use of the pivoting shield (heel compensation)

On principle, the pivoting shield of the combine can be used combined with the majority of the corn headers without any limitation, unless otherwise specified.

The instructions of the combine manufacturer to follow!

PTO-shaft length to check in all positions.

If required, special locks (R) to mount to upper adapter frame and secure.

Always trial run to conduct!

Instructions for PTO-shaft drives to observe!



Multicoupler

If the combine is fitted with a multicoupler (optional), the header should be fitted likewise.

The suitable coupler (optional) can be added to the supply.

The operation to be made according to the instructions of the combine manufacturer.



**When checking the functions, keep off the dangerous zone.
Tightness to check!
In case of leakages the conditions for environmental protection to follow !**



Connection via control valve coupler

Some combine makes require using a control valve coupler (M) for connecting the header.

The respective headers are fitted accordingly as standard.

The operation to be made according to the instructions of the combine manufacturer.



**When checking the functions, keep off the dangerous zone.
Tightness to check!
In case of leakages the conditions for environmental protection to follow!**

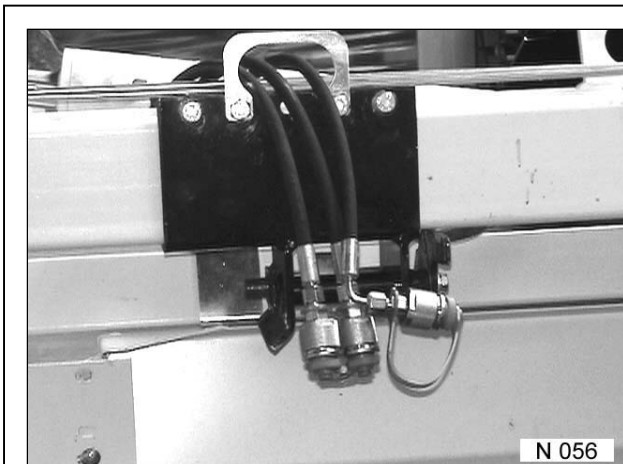

Connection via simple screw and/or slip-on couplers

If only simple slip-on and/or screw couplings are available, first double and simple-acting lines are to mark.

The simple-acting line is to connect to the line of the stripping plate adjustment.

The double-acting lines serve to the control of the folding process of the respective headers.

Establish a safe connection to allow the oil flowing !

Lines to mark and always immediately to connect so that the working purpose remains unchanged!

Hydraulic actuation of the folding process

Reel:

“Lifting and lowering ” = stripping plates “ open and closed ”

Reel horizontal adjustment: (optional)

“ forward and backward ” = folding process “ open and closed ”



**When checking the functions, keep off the dangerous zone.
Tightness to check!
In case of leakages the conditions for environmental protection to follow.**

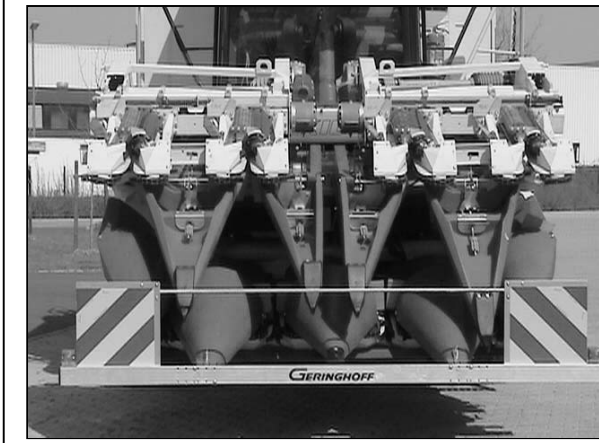

Folding process (from transport in working position)

Reel horizontal adjustment of the combine to actuate until the header has reached its working position.



**Keep off the dangerous zone!
Keep off the working range of the header!**

Valve actuation not to finish until 10 seconds after complete closing of the cover shields (to assure the locking function).

Machine to run idle to get the drive coupler engaged.

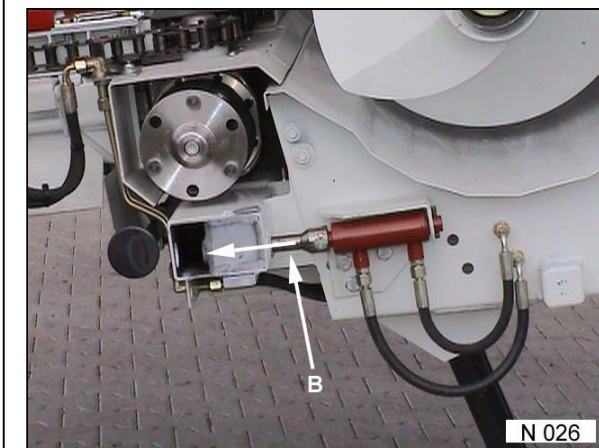

Locking

Once the header is completely open in working position, the locking (B) is automatically activated.

If the header is not completely open in working position, to troubleshoot.

(see help in case of malfunctions, page 10 / 900)

There are possibly foreign substances hindering the function.

Bolt (B) must completely extend in locked state.

Check drive coupler! Cams are spring-loaded and turn off unless cam and opening in driving plate are not in line!

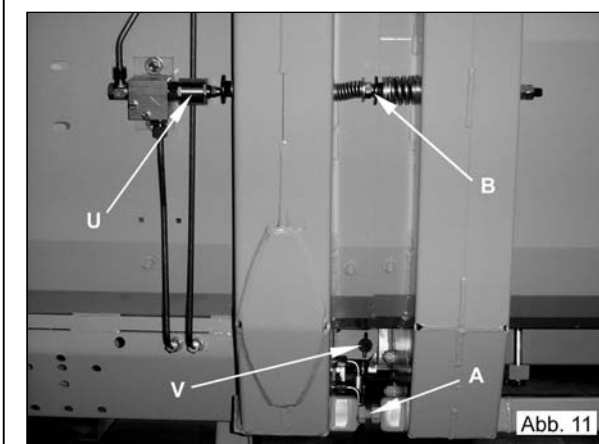

Control valve for locking

The locking (V) is triggered by the valve (U) and closes only if the header has really reached its working position.

If the locking is not activated despite of sitting closely on the stop screws (A), on-off valve (U) to readjust with screw (B), if required!

If required, stop screws on the bottom frame and locking bolts (V) to readjust.

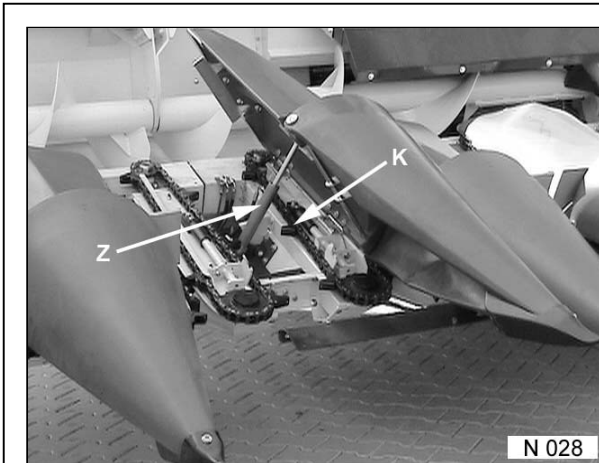

Automatically closing cover shields

Cover shields (A) close only after complete extension of the locking bolt.

Failing which, to troubleshoot.

Factory adjustment has been checked. Corrections are in general not required.

Folding process is not finished until the cover shields are completely closed.

Attention!

Machine not to run with opened shields. Hydraulic cylinder (Z) would get in contact with the gathering chain.

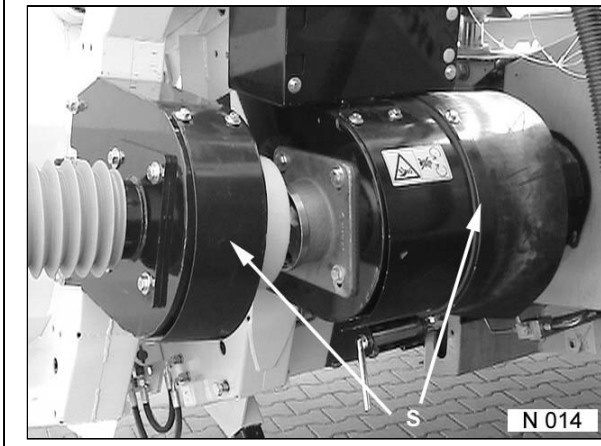

Drive coupler folding headers

The drive coupler, if any, ensures an automatic coupling of the PTO-shaft drive.

Prior to start-up and then in regular intervals the correct position of the coupling halves to check.

Check the protective devices (S) for correct fitting.

Machine always to let idle.



Persons to keep off the dangerous zone!

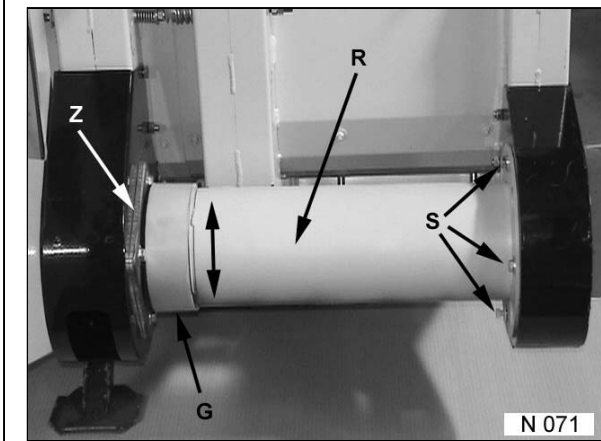

Drive coupler 6-row folding headers

The coupling half mounted to the folding element is adjusted only via the protective tube (R).

If the coupling halves must be readjusted, screws (S) to loosen and protective tube to displace accordingly.

Parallel fitting of the coupling halves absolutely to assure.

The coupling halves to axially regulate only via spacers (Z) below the bearing.

Correct fitting of the protective ring (G) to ensure.

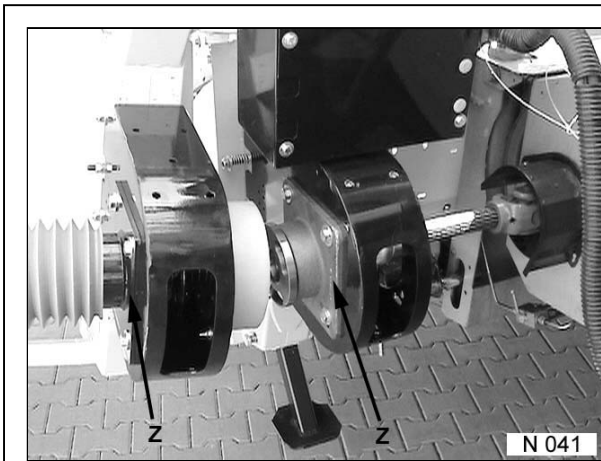

Header with drive couplers on both sides

From a certain number of rows the headers are fitted with a both-sided drive.

If the coupling halves require an axial regulation, spacers (Z) only to use on the marked positions.

The radial adjustment is made on the bearing points by displacing the bearings into the bores provided.

The parallel fitting of the coupling halves absolutely to ensure.

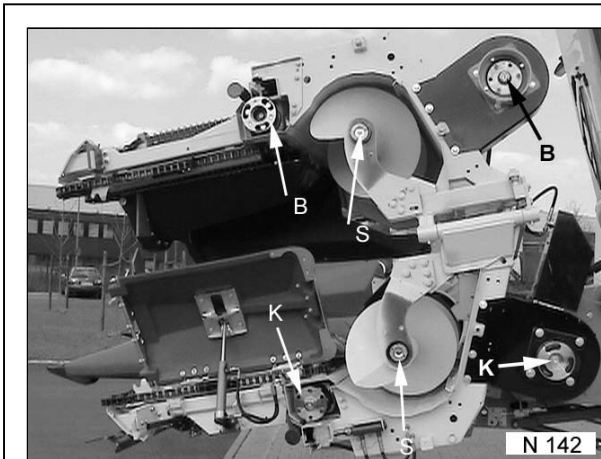

Maintenance and care

Coupling washers (S + B + K) to be slightly greased in regular intervals.

Sliding parts of the respective coupling halves once to dismount prior to start working and sliding parts to grease.

Axial fastening screw carefully to tighten with standard torque.

Header drive not to set into operation if the header is in collapsed state.



Risk of accident on the coupling halves!

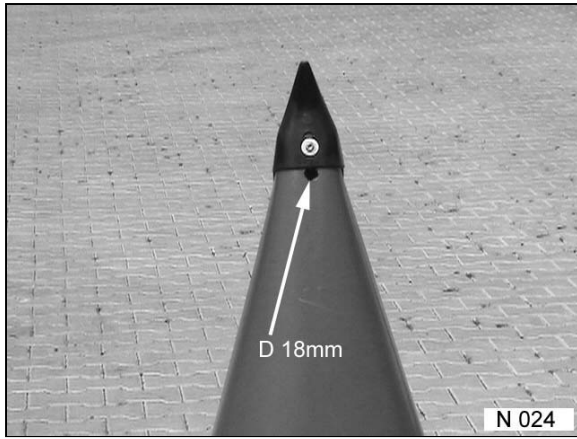

Selection of the divider noses for mounting

Divider noses with bore (D)

The supplied center divider noses differ only by a bore (D) about 18 mm Ø if the header has been supplied with a transport protection.

These center divider noses are to mount right and left (T) from the center (M) for receiving the transport protection.

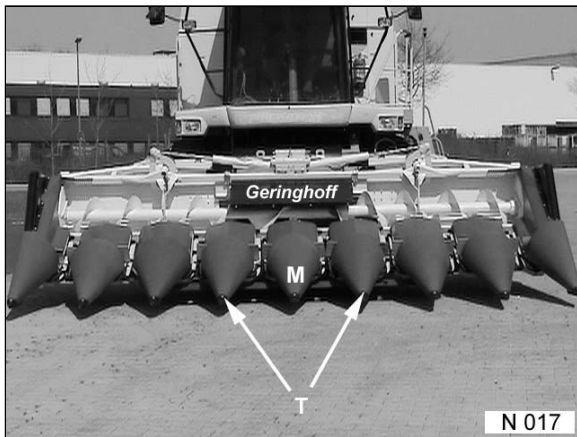

Corn header to lift and secure via support on the lifting cylinders against unwanted lowering!

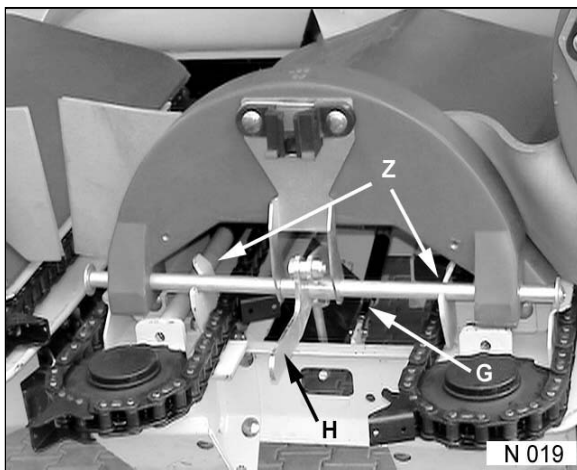

Mounting of the center divider noses

Shield to open by throwing over the lever (H) and slightly to press upwards from the centerings to the stop of the gas pressure spring.



Shields may jump upwards by gas pressure cylinder!

Tube (R) to remove once unscrewed the axial screwing (S). Tube to put in provided bore of the divider nose and shield. Screwing to tighten.

Divider nose to lift and setting bar (E) to hang into the support (A). Safety bolt (B) to mount and secure by cotter pin.

Shield strongly to press down for closing and to check that locking pin hooks in. Via lever (H) shield to close with moderate prestress. If required, locking hook to readjust.

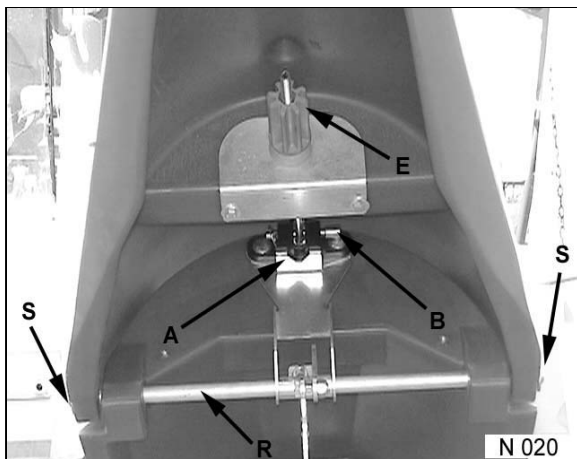

Mounting of outer divider

The same procedures as with the center divider noses.



Risk of bruising when mounting shields and divider noses !

The divider noses are adjusted via the screw (E).

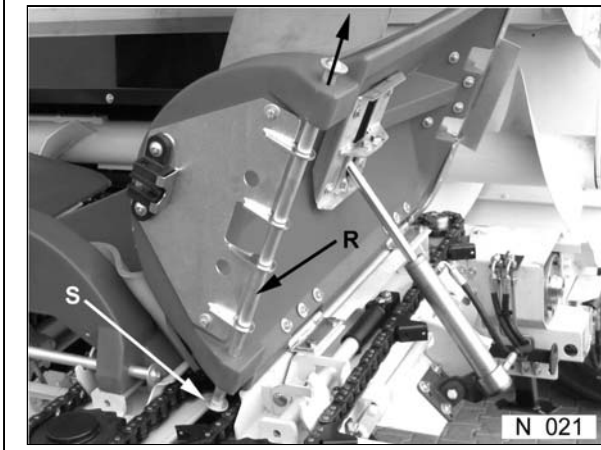

The center divider noses to mount to the shields

Only possible with the hydraulic connection already mounted.

Start folding process. If folding shields are open, procedure to stop.



**Motor to turn off !
Corn header to secure against unwanted lowering!**

Mounting procedure of the divider noses is the same as for the other center noses.

The divider noses are adjusted via the screw (E).

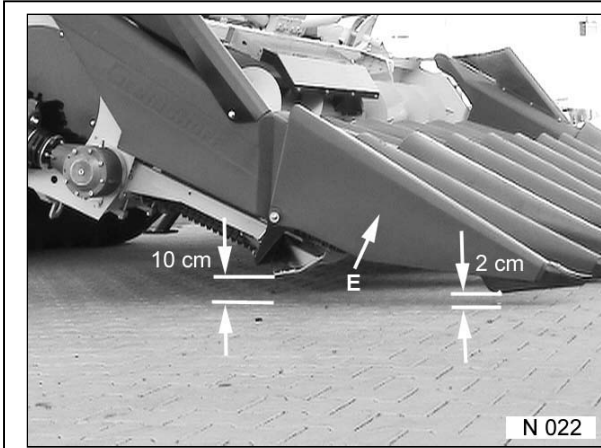

Adjustment of the divider noses

Protection against lowering to remove.

Header to lower to a ground distance of about 10 cm on an even surface.

Divider noses with screw (E) to adjust such that their distance to the ground is 2 cm (normal adjustment).

On the harvest of lodged maize and if the combine sinks into the deep ground, the noses are to lower deeper.

Attention!

In case of an extremely lower adjustment, ensure that the divider noses don't get in touch with the gathering chains!



Mounting of the increased shield

For transport size and package reasons the increased side shield is supplied unpacked.

It is mounted to the outer bodywork into the provided threaded bores (G).

Attention!

All screws of the plastic parts normally to tighten to prevent the bores from being damaged.

The harvest can be made on option even without these increases.

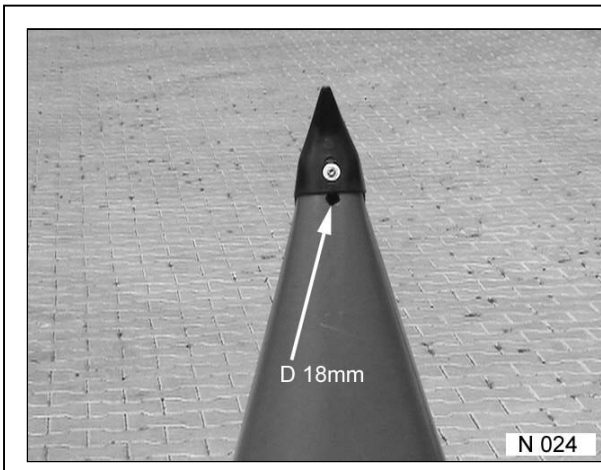

Bores to drill for transport protection

If divider noses have been mixed up on assembly or supply, the required bores can be drilled into the both center divider noses on the site.

Directly behind the divider nose top plate an 18 mm Ø bore to drill only into the upper plastic surface.

The respective center divider noses are selected according to the specifications of the transport protection or to picture N 017 on page 09 / 320.

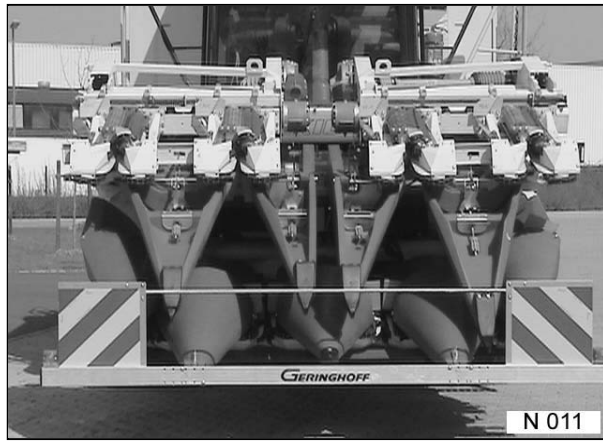

Front protection

Unfolding headers up to a transport width of 3,0 m are fitted with an unlighted transport protection.

All foldable headers up to a transport width of 3,3 m are fitted with a lighted transport protection.

The connection is made via a standard socket which, if not available, must be mounted on or below the driver stand.

The outer unfolding center divider noses are provided with bores for locking the transport protection.

(see page: divider noses to mount, page 09 / 320)

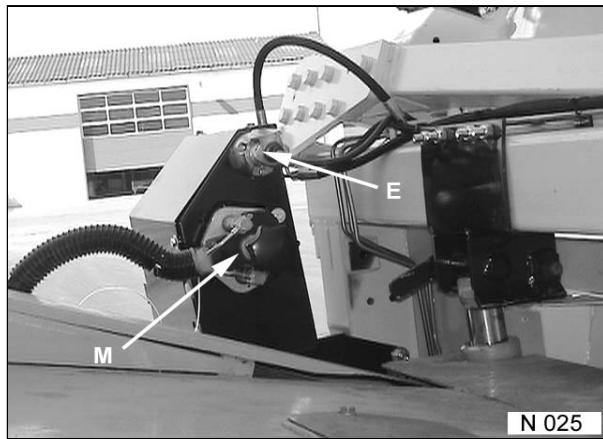

Front protection with lighting connection

on multicoupler and/or control valve unit

In certain combine makes the lighting connection for the front protection is integrated into the general supply line (M) to the header.

- The front connection is then connected to the socket (E).
- If required, the front protection is connected via another individual connection.

Instructions of the combine manufacturer to follow!

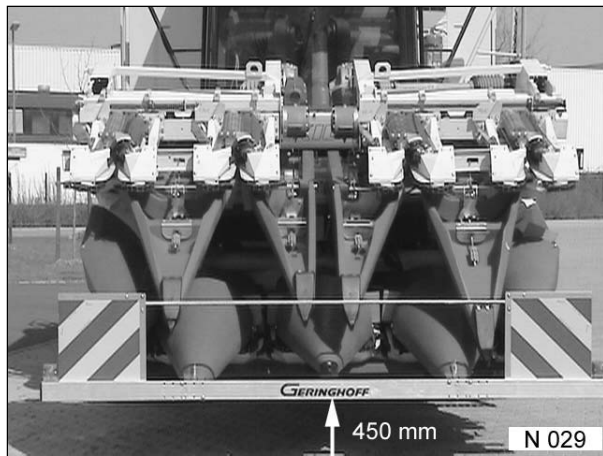

Transport on public roads

It's not allowed to transport the corn header on public roads without transport protection.

The maximum admissible height of the slewing arm of the ejecting channel on the transport on public roads is about 0,45 m as measured on the front protection (H) and is determined for each machine in the separate licensing documents.

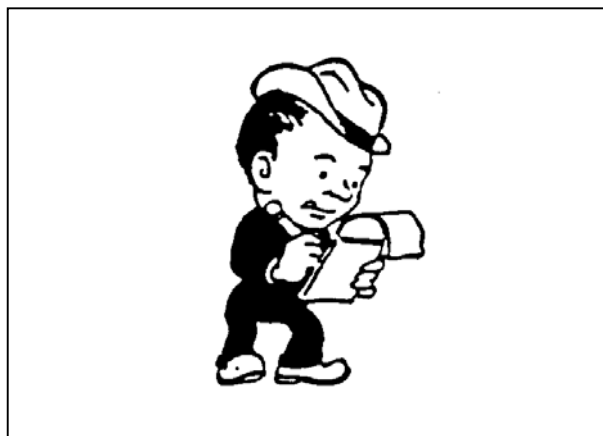

Road transport licensing and TÜV-regulations as well as instructions of the combine manufacturer absolutely to observe.

A TÜV-expertise is enclosed to each machine.

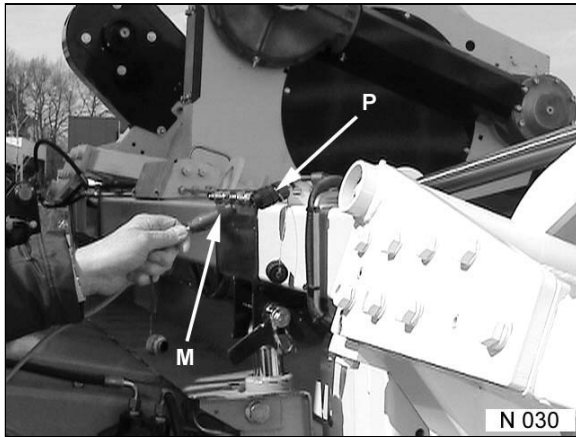

Monitor to connect to the header

Plug-type connector of the monitor cable coming from the driver cabin to connect right with the header coupler.

Current supply to activate as described on page 09 / 080

Speed indication on monitor reads „ 0 “.

If the machine is running on operational conditions, a value of about 720 - 750 r/min is indicated.

The speed indication allows to reliably evaluate the state and load of the combine against the header.

Dropping speeds signal either an insufficient belt tension or overload of the combine drive.

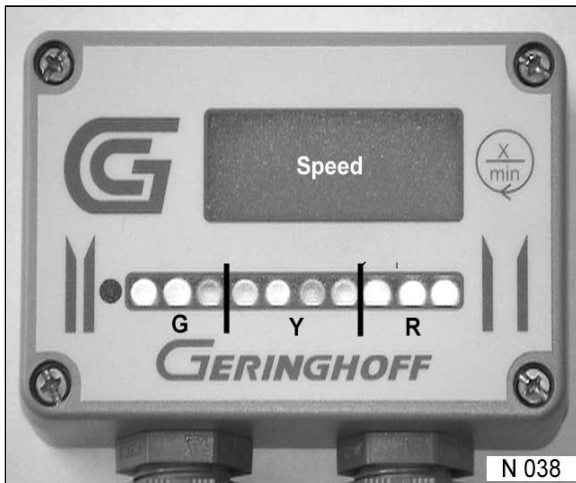

Stripping plate adjustment

Subject to the position of the stripping plates, a certain number of green (G), yellow (Y) or red (R) diodes light up.

The more the stripping plates are open, the more diodes are lighting up.

The number of the flashing diodes is only to be seen on the monitor. Before the start-up, the proportion of the flashing diodes to the position of the stripping plates as a function of the harvest conditions is to be determined.



Prior to checking, Diesel motor to turn off! Keep your hands off the stripping plates!

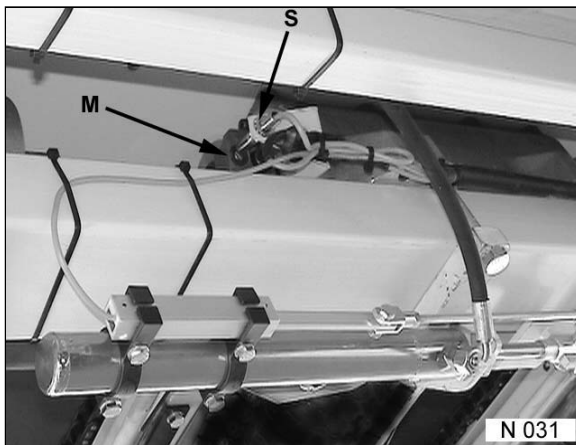

Recording tachometer

The recording tachometer (S) is located between two rows on the drive connection claw of the Centaflex-coupler.

The distance between the magnetic switch (S) to the magnet (M) and/or claw should at least be 1,5 mm and at max. 2,5 mm.

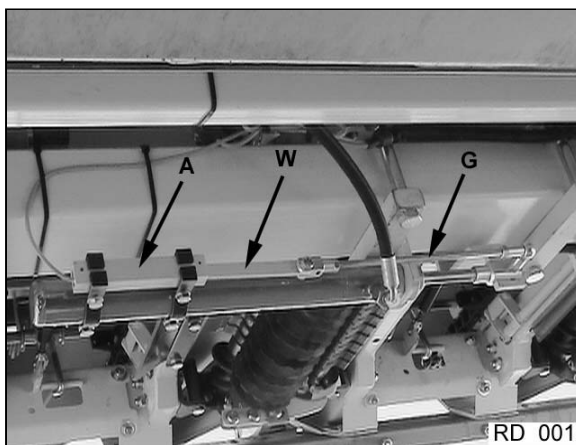

Rheostat of stripping plate adjustment

The rheostat (A) and the slider (W) should be cleaned in regular intervals.

Via the axial adjustment of the spindle (G) and by displacing the position of the rheostat (A), the indication of the diodes allows individually to be changed.

Electric supply lines to be checked in regular intervals.



Prior to checking, Diesel motor to turn off!

Header to be secured against unwanted lowering!

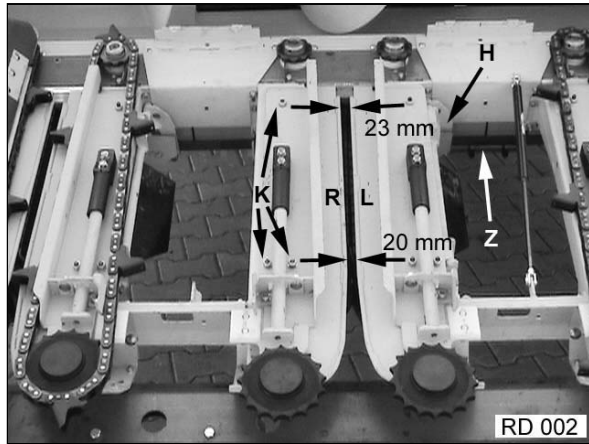

Function and basic adjustment

The basic front adjustment is 20 mm and the rear one 23 mm in position „ narrow “. That means, the stripping plates are pushed together as far as possible.

The wedge-shaped adjustment is of essence for the function of the header.

These values are set via the screwed down stripping plate (R) and the screws (K).

For the harvest, the stripping plates are operated hydraulically via „reel to lift and lower“.

The average corn ear diameter is important for the setting of the stripping plate distance. For this reason, the plates for the harvest works should be opened as far as possible, just as far as to prevent cob losses.

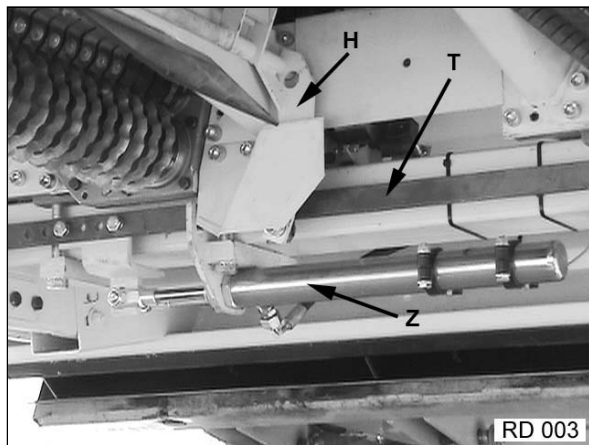

**Prior to checking, Diesel motor to turn off!
Header to secure against unwanted lowering!**

Via the shifting cylinder (Z) the left stripping plates are opened by the sliding bar (T) and lever (H). The plates are closed again by one or several restoring springs.

The regulation of the uniform setting of all stripping plates on the different rows is made by shifting the levers (H) on the sliding bar (T).

Before going to make a readjustment, it is recommended to check the basic adjustment „in front 20 mm, rear 23 mm“.

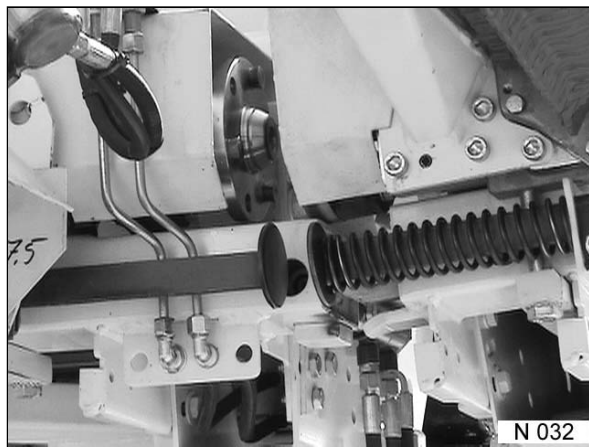

Stripping plate adjustment folding headers

The function and layout is identical to the unfolding machines.

The stripping plates on the folding parts are actuated via the spring-loaded sliding bar contact. Additional, right and left differently mounted restoring springs open the plates on activation of the folding process.

Pressure plates should well overlap.

Adjustment and setting to be made in working position and adequate locking only.

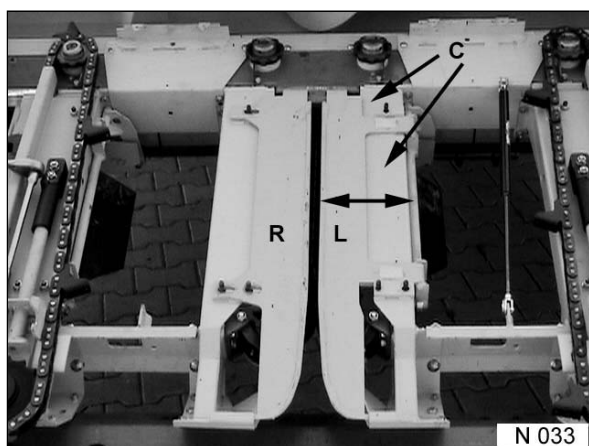

Maintenance and care of the stripping plate adjustment

Impurities are not to exclude. For that reason, at least once the day the stripping plates (L) to open and close several times to assure the free floating and to remove impurities.

Joints to oil every 100 h. Restoring springs to clean.

Once finished the harvest works, bearing (C) of the adjustable stripping plate (L) to clean and to protect against corrosion using adequate means.

Check that the cut-off block is centrally arranged in central working position.

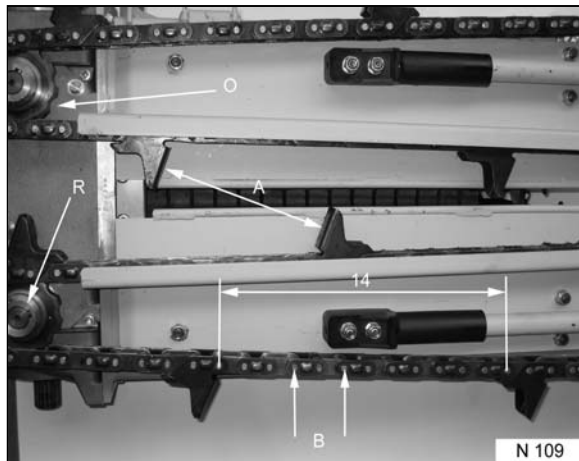

Gathering chains

Special slipping wheels (R) are to secure the gathering chains and to prevent the penetration of foreign substances.

The position of the gathering chain drivers (A) to each other is permanently changing, even on normal harvest operation by response of the slipping function.

When stating a chain elongation (ill. N 107), there is the unique chance of shortening the chain by one outer and inner link plate each (B). The shortening to be made in the area (14) = 14 pcs. link pin distance from driver to driver.

The plastic protective rings (O) beneath the slipping wheels to be checked for good state.



Chain tensioner

The maintenance-free gathering chains are automatically tensioned via constant spring pressure.

The preset chain tension is also to regulate the driving torque of the gathering chain and thus the efficiency of the slipping wheels.

When to change the gathering chains?

A = 83 mm chain in new state

A = 113 mm chain worn-out, replacement required.

Attention!

Consider also the wear of the frontal reversing wheels!

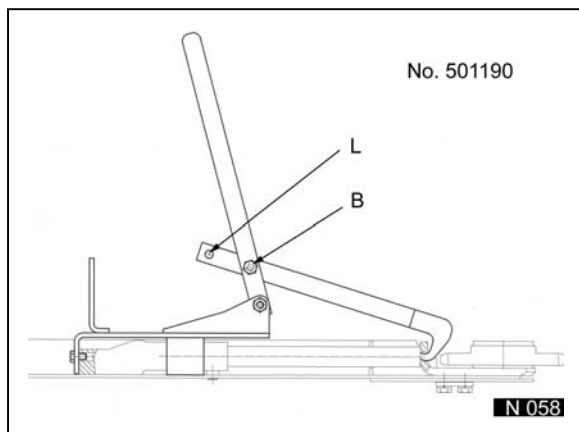

Dismounting of the gathering chains

The chains can be dismounted with ease by using a special tool, spare part no. 501190 attached to the header.



Prior to working on the machine, Diesel engine to turn off. Special tool may jump back!

The gathering chains are recommended to be changed once the year from right to left and viceversa to ensure thus a uniform wear.

Frontal chain reversion to dismount

Tool for chain dismounting to place to pos. (B) as shown in ill. N 058 and N 198 and to pull tight. Lever to secure under hook (E).

The frontal reversing chain wheels to be dismounted in the same way. Special tool to mount into bore (L). Lever to secure under hook (E), then the fastening beneath the reversing wheel to remove and tool slowly and carefully to relieve.

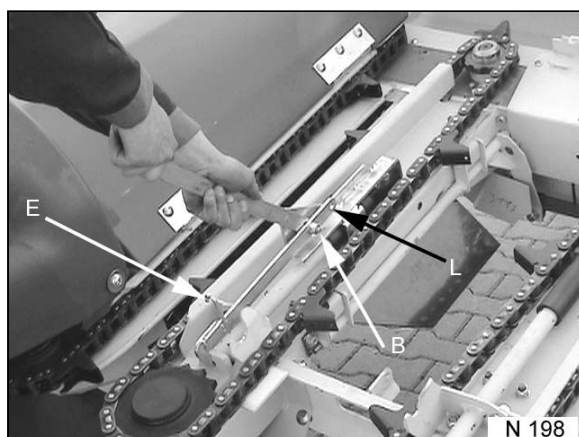

Tool jumps back by ! spring pressure Risk of accident!



Row unit transmission



Corn header to lift to a height of about 1 m to allow the lowering protection to engage. Turn of Diesel engine!

The oil level is controlled by a standard dip stick on the oil filling plug.

Gauge position: Header lifted to about 1 m.

Filling level: 1,5 l gear oil SAE 90 (commercial quality)

Changing interval: 50 h from start-up, then once before each harvest but at latest after 500 h.

Oil drain plug (not visible) is fitted with magnet, which must be cleaned on each oil change.

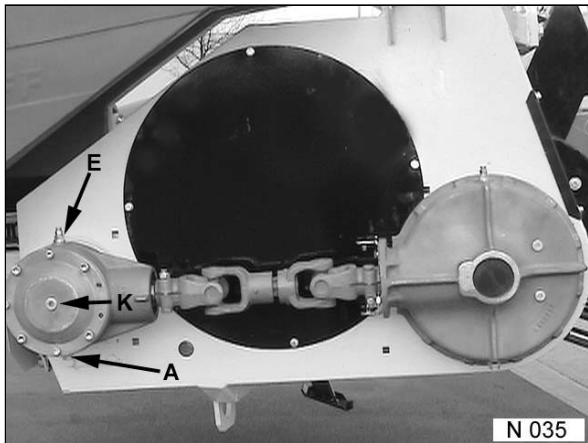

Angular transmission

Oil level control of angular gear via central gauge plug (K).

Filling level: 1,5 l gear oil SAE 90 (commercial quality) to fill to the escape on gauge opening.

Changing interval: 50 h from start-up, then once before each harvest but at latest after 300 h.

Oil drain plug (A) is fitted with magnet, which must be cleaned on each oil change.

In folded state, exhauster (E) to be checked in regular intervals.

Oil level to be checked in regular intervals!

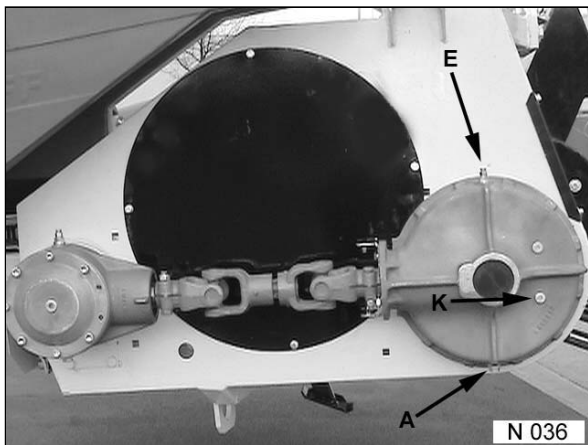

Contrate gear transmission

Oil level control via gauge plug beneath gear center (K).

Filling level: 1,5 l gear oil SAE 90 (commercial quality) To fill up to the escape on the gauge opening.

Changing interval: 50 h from start-up, then once before each harvest but at latest after 200 h.

Oil drain plug (A) is fitted with magnet, which must be cleaned on each oil change.

In folded state, exhauster (E) to be checked in regular intervals.

Oil level to be checked in regular intervals!

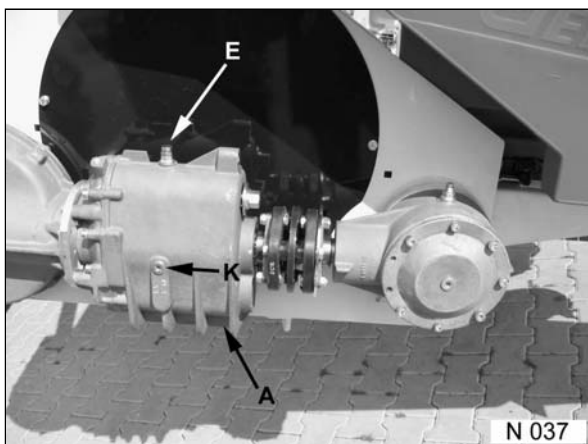

Change speed gear 2, 3 or 5 gears (optional)

Oil level control via gauge plug (K).

Filling level: 1,5 l gear oil SAE 90 (commercial quality) To fill up to the escape on the gauge opening.

Changing interval: 50 h from start-up, then once before each harvest but at latest after 200 h.

Oil drain plug (A) is fitted with magnet, which must be cleaned on each oil change.

In folded state, exhauster (E) to be checked in regular intervals.

Oil level to be checked in regular intervals!

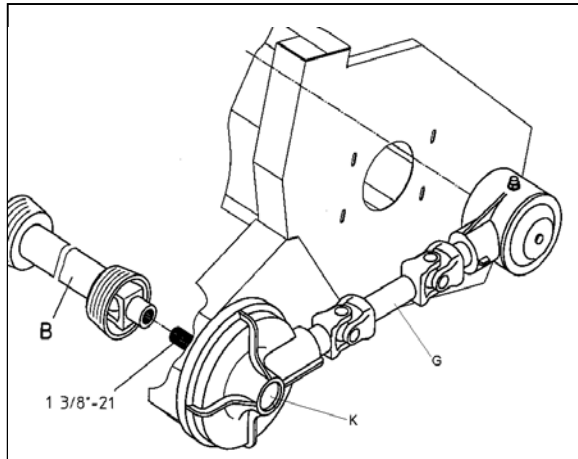

Nominal speed is not reached

Unless reaching the nominal speed of the header of about $n = 720 - 750 \text{ U/min.}$, the speed can be corrected by changing the contrate gear within the transmission (K).

First to check whether the speed of the combine on the PTO-shaft connection (B) in question is in line with the factory specifications.

On the transmission box is marked a number on the pos. (Z) showing the teeth number of the contrate gear.

The following formula allows to calculate the speed:

$$\text{Combine speed} \times \text{teeth number of contrate gear} / 32 = \text{header speed}$$

Change of contrate gear

PTO-shafts (B+G) to remove.

Screws of the transmission fastening on the backside to remove and the complete contrate gear transmission to take off the header.

New contrate gear to get from the manufacturer or dealer.

Attention!

The contrate gears are available only in certain gradations. If intermediate speeds are required or wanted, change speed gear to be mounted (page 35 / 010).

Changed teeth number of the contrate gear to mark on the transmission box!

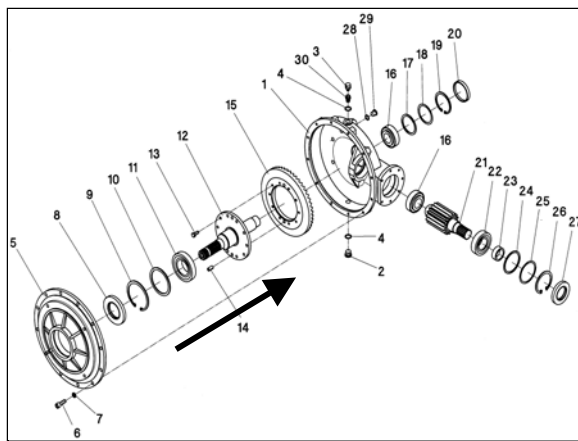
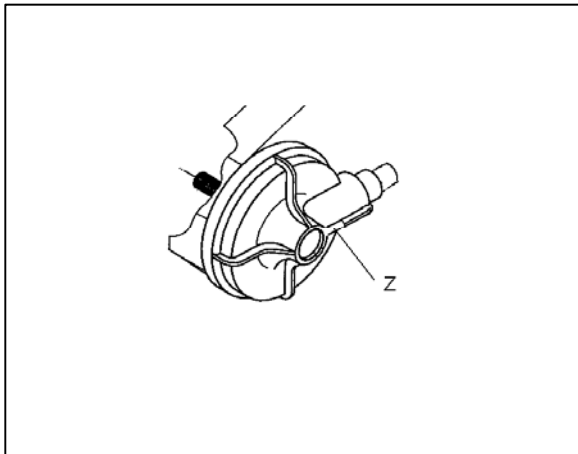

Opening of the transmission

Transmission to put down horizontally to avoid oil losses.

Screws (6) to remove.

Box cover to loosen by knocking with an adequate tool and to take off. Shaft (12) with bearing (11) is still in the cover (5).

Shaft (12) to drive out of the box cover (5) in arrow direction.

Screws (13) to remove and contrate gear (15) to replace.

Works to be performed by an expert only.

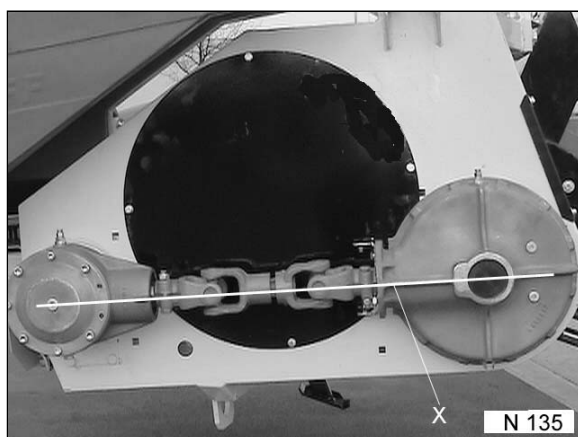

Contrate gear transmission to remount to the header

Contrate gear transmission to mount to the provided place, if required together with PTO-shafts.

Fastening screws slightly to tighten such as to allow the transmission still to be aligned (see white line X).

Only original screw length (6) to use, since longer screws would destroy the transmission housing.

Guards to mount and trial run to conduct. Check the speed!

Oil level to check.

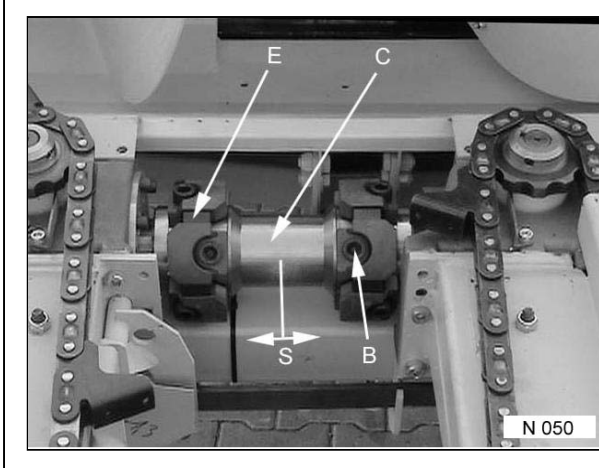

Centaflex-couplers

Centaflex-couplers (C) to be checked in regular intervals for the state of the flexible elements (E) and engaging dogs.

Worn parts to replace immediately.

Axial clearance (S) of 2 mm for the center part (C) absolutely to keep.

Hexagon socket screws (B) to tighten with 140 Nm.

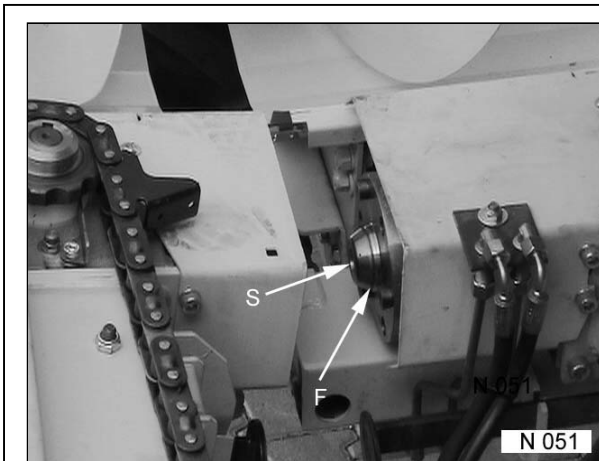

Row unit drive connections on the folding parts

The axial movability of the coupling half (F) to be checked in regular intervals by mounting lever to be pressed in.

If required, axial safety bolt (S) to unscrew, coupling half to pull off, splined shaft section to clean and grease.

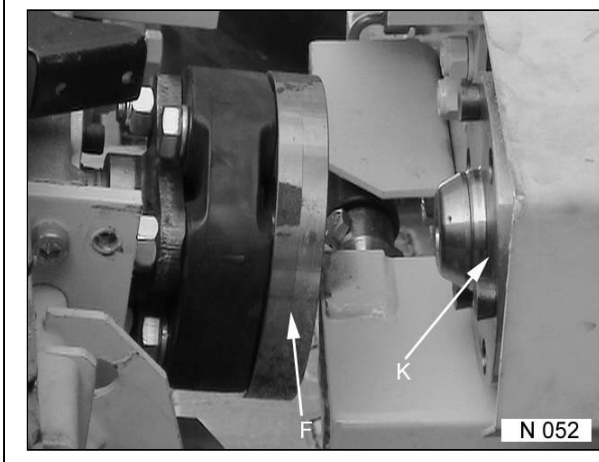

The parallel position of the cam plate (K) towards the punched disk (F) to be checked in regular intervals with the machine put out of operation and the coupler engaged.

Radial differences are to be compensated by readjustments made on the pivot of the folding part suspension.



Drive couplers to get engaged only at minimum speeds.

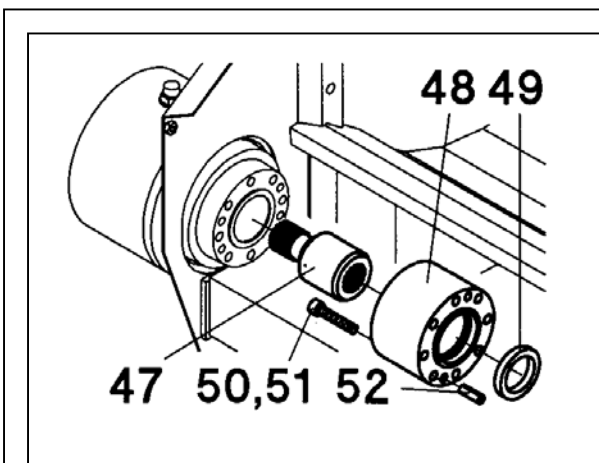

Corn header with shaft extension (optional)

Corn headers with certain row distances can be fitted with a shaft extension on the drive side.

Flange (48) and intermediate shaft (47) are arranged between angular gear and the row unit gear.

The intermediate shaft needs no maintenance at all.



First trial run



Corn header to lower near to the ground. Keep off the dangerous zone. All guards to close!

Machine first to let idle.

Check the smoothness of running.

In case of trouble turn off immediately!
Secure against unwanted lowering!
Troubleshoot!

Check the working speed on the monitor.
(n =720-750 r/min)

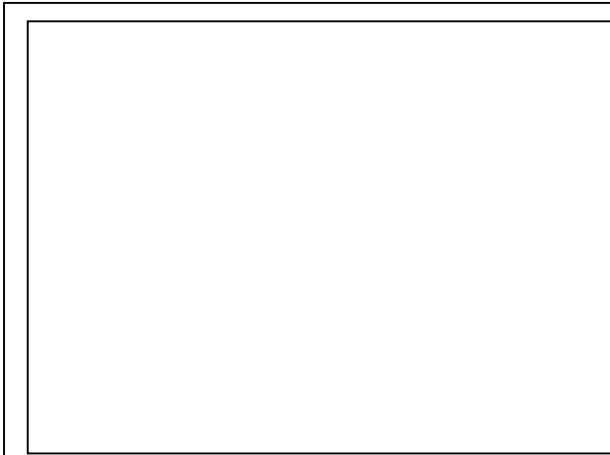

Reversing

All modern combines are fitted with a standard reversing device for the header drive.

This device for allowing the machine to reverse can be used for cleaning during the operation of the header without any limitation.

- Function to check

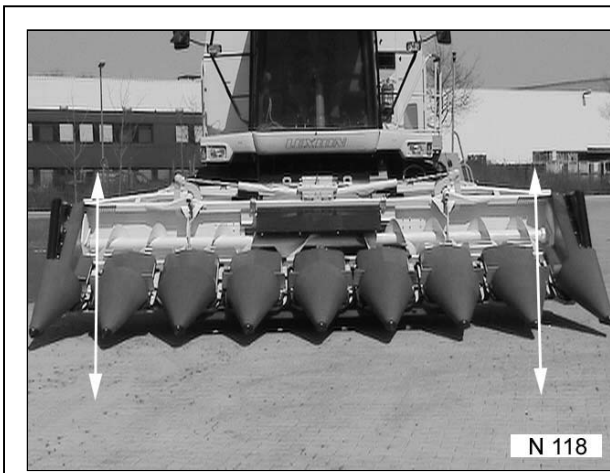

Test of the heeling compensation

Prior to start-up, the pivoting shield function of the combine is to be checked combined with the corn header.

- PTO-shaft length and sufficient overlapping to check!
- Slope steering to check (optional)



Keep off the dangerous zone whilst the machine is running !

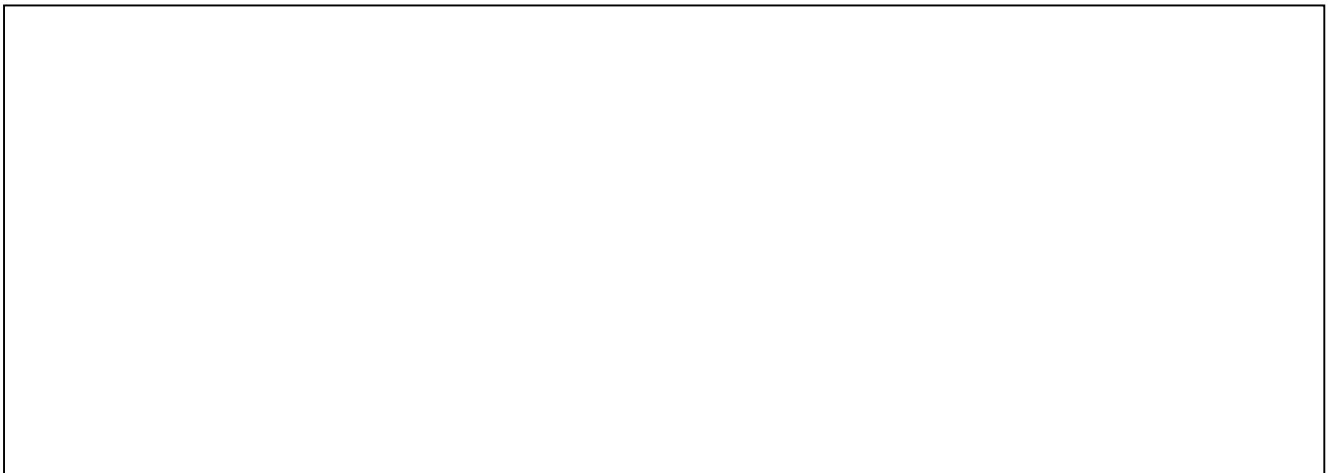

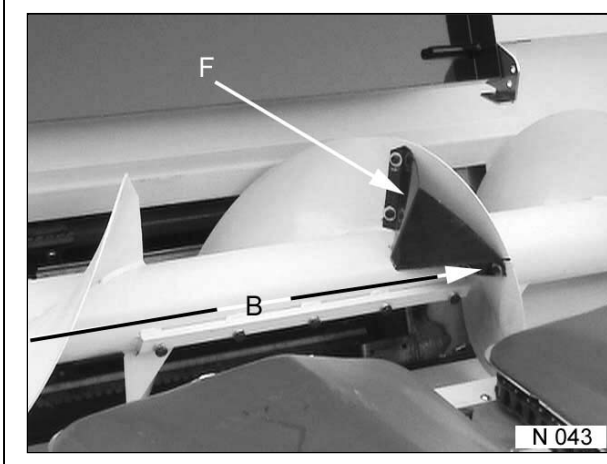

Conveying aids

The conveying aids (F) are mounted as standard on the cross conveying auger.

On option, these conveying aids can be enclosed unpacked and mounted on the site.

In the event of a not uniform feeding all over the combine width, the conveying aid (size B) is to mount 40 mm narrower than the inside gathering channel width is.

That means the size (B) must be 40 mm smaller than the channel opening of the combine.

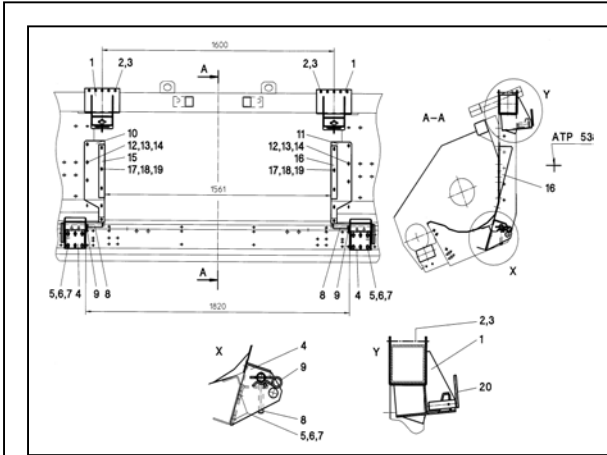

Feed opening of the corn header

Certain opening sizes of the header for all combine makes and models are determined for the feeding to the gathering channel of the combine.

The exact opening width to be learnt from the sketches in the spare part catalogue from picture table 60/.. .

For standardization reasons, slight variations from the rated size are allowed.

In particular when working on slopes a regular feeding is of essence for the harvest material to be distributed evenly within the machine.

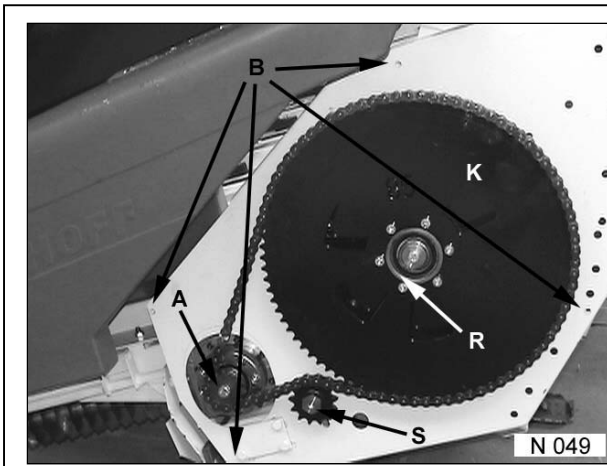

Auger drive up to 6 row units

The auger is driven from the side opposite to the main drive. The speed is subject to the main shaft of the header and thus preset.

Chain tension to check in regular intervals, if required, to readjust via the idler (S).

Chain to oil in regular intervals.
Protection box to clean in regular intervals.



Corn header never to operate without guards mounted and closed!

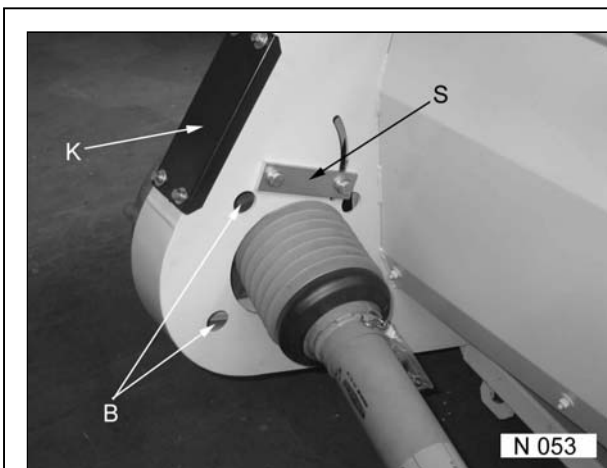

Auger drive from 8 row units

The auger is driven from the feed shaft of the contrate gear transmission and is not subject to the speed of the header.

Maintenance and care of the chain drive to be made via the flap (K)

The chain tension is adjusted by shifting the tension lever (S) downwards.

All bearings of the cross conveying auger are maintenance-free.

The bores (B) serve to fasten the contrate gear transmission.

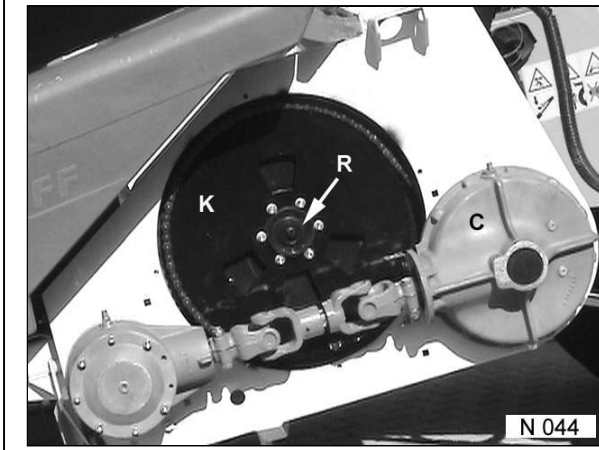

Sliding clutch cross conveying auger

All auger drives are fitted with a maintenance-free and not readjustable sliding clutch.

If the sliding clutch reacts, machine immediately to turn off and troubleshoot.

Insufficient torque of the clutch cannot be decisive for the response behaviour.

In case of overfeeding, the reversing device of the combine allows for a refeeding.

Chain drive to grease and tension in regular intervals.

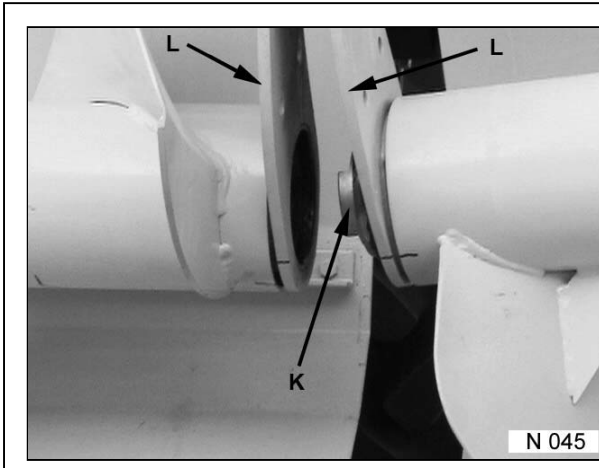

Driving clutch cross conveying auger

The coupling halves (K) in the folding auger elements are spring-loaded mounted on a splined shaft section engaging automatically after the folding process.

Axial spring load of the clutch (K) several times to be checked during the harvest season by simple pressing in.

The screw joint of the bearing holders (L) serves to the adjustment of the auger elements.

Once finished the setting works, the screws to remove.

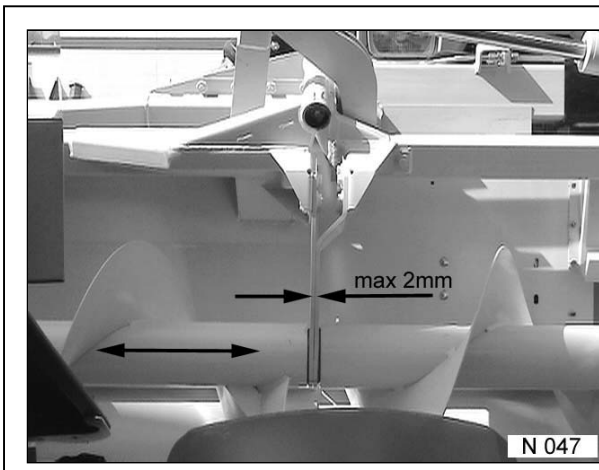

Setting of the cross conveying auger

The cross auger is factory-mounted in ideal position and not provided for being displaced.

Provided setting facilities serve only to the assembly of the cross conveying auger.

Bearing holders (L) must in working position be parallel and close to each other (max. 2 mm distance).

If the bearing holders (L) are too far from each other, the corresponding auger element can be regulated by axial displacement. For doing so, the locking ring of the respective bearing to loosen.

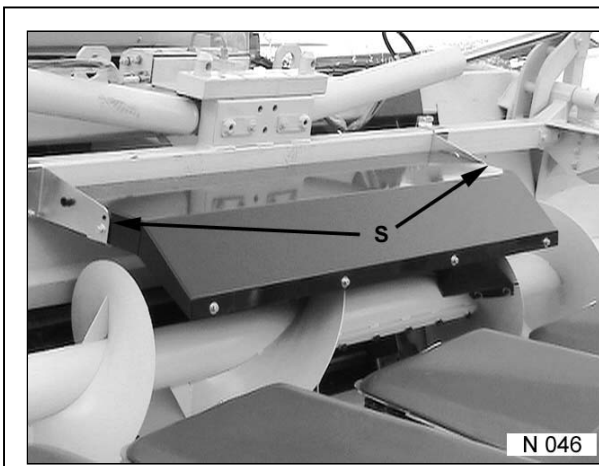

Covering cap cross conveying auger

The height adjustment of the covering cap is made via the screwing (S).

The distance between auger and cap should be as big as possible to ensure a free passage of husks, leaf and even stalk parts.



Prior to working on he corn header, Diesel motor to turn off!

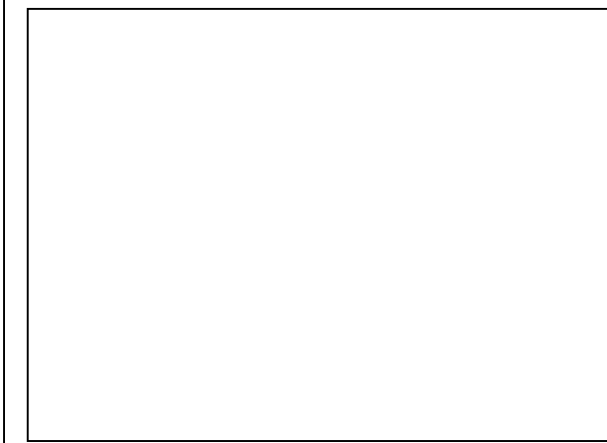

Basic equipment of all headers

A number of overload protections and slipping clutches are provided for the safe operation of the machine.



**If these devices respond, corn header immediately to turn off!
Diesel motor of the combine also to turn off and header to secure against unwanted lowering!**

Troubleshoot and trouble to rectify.

Never switch the header on and off to get it turning again.

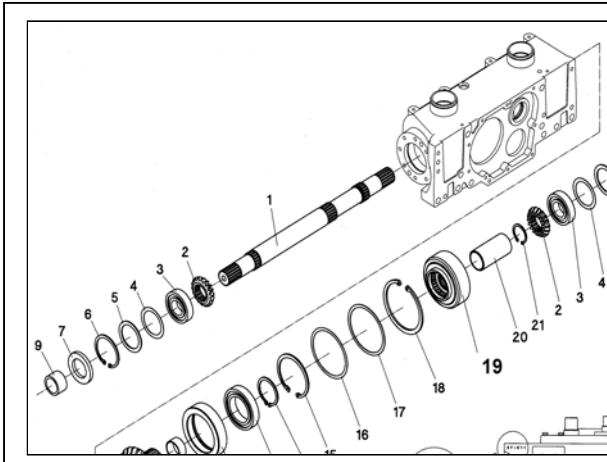

Sliding clutch in the row unit gear

One maintenance-free and wear-poor cam clutch each (19) is arranged within the gears.

If it responds, there is a trouble beside the normal operational conditions.

Once stated that the foreign body did not cause the response behaviour, the reversing device of the combine allows the header to be turned backwards and to remove sticking harvest material.

Clutch must not run hot!

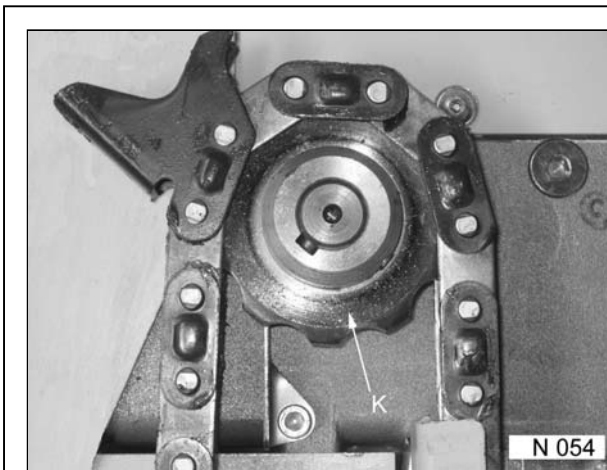

Slipping wheels on the gathering chains

See also page 09 / 520

The special tooth form of the driving chain wheels (K) combined with the automatically tensioned gathering chains effect a well-balanced driving torque of the gathering chain drive.

In case of overload or foreign bodies the driving chain wheel turns within the gathering chain without moving it ahead. That ensures that damages are prevented and foreign bodies kept away from the combine.

Never to change the chain tension using inadequate tools.

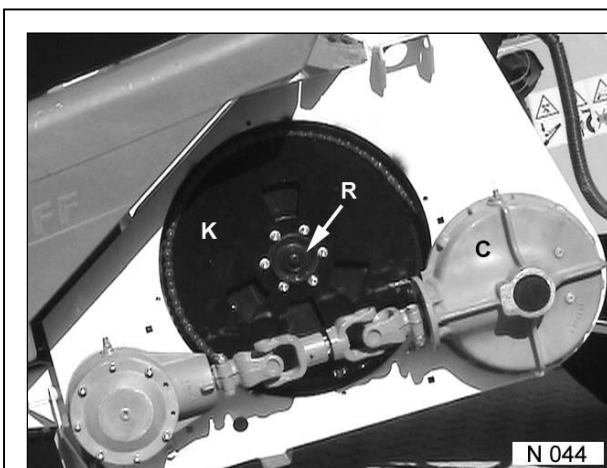

Slipping clutch in the cross auger drive

A not readjustable cam clutch is mounted on the drive side of the auger shaft.

If it responds, there is a trouble beside the normal operational conditions.

Once stated that the foreign body did not cause the response behaviour, the reversing device of the combine allows the header to be turned backwards and to remove sticking harvest material.

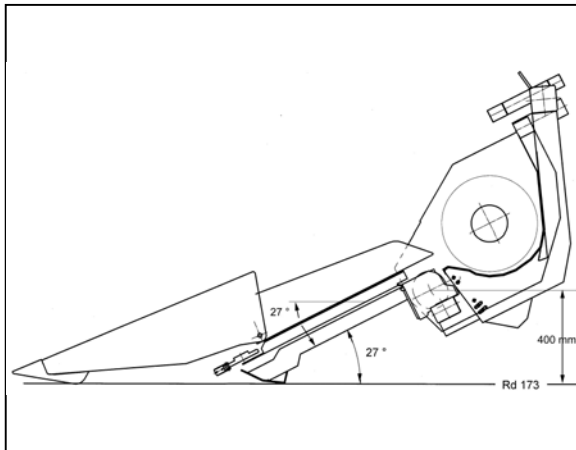

Working angle (basic position)

A working angle of 27° is factory-set. If the combine is fitted with larger or smaller tires than the series equipment, we recommend checking the working angle. The same applies also to crawlers.

The real angle is to be determined with ease by placing an adjustable angle on the stripping plates in working position and a bubble level.

This check should be made on real working conditions on the field with the usual ground spacing.

When putting the header down to 27°, a control dimension of about 400 mm of shaft spacing to the ground will result.



Adjustment of the working angle

Combine and corn header, completely mounted, to put down in working position on a level surface.

Screwing of the outer bodywork suspension on the frame to remove.

Guard (C) of the gear drive to remove.

On foldable headers, the locking must absolutely be activated in working position (see 09/240).



Header, completely relieved but firmly connected to the combine, to be put down to the ground!

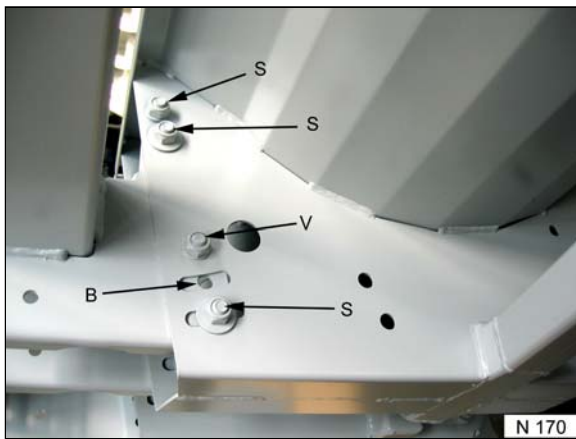

Adjusting device

When the machine has been put down, first the screw (V) to remove from all frame connections and to put into the bore (B).

Then, screws (S) on all frame connections, also on the sidewalls, slightly to loosen for allowing the elements to be moved to each other.

The required working angle to adjust via the lifting device of the combine (header to lift and/or lower).

Then all screws of the frame connection to retighten with the header being put down!

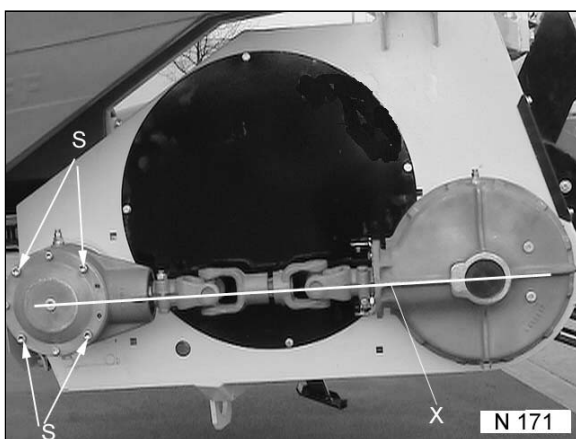

Drive gear to align

Corn header with the gathering channel to lift and secure against unwanted lowering.

Only the four screws (S) Sw 8 of the angular gear and the four screws of the contrate gear fastening on the backside to loosen. Both the gears to turn until reaching the exact alignment (see line X).

Gear to refasten and guard to remount.

Outer framework to be connected again. If required, spacing to be compensated by spacers.

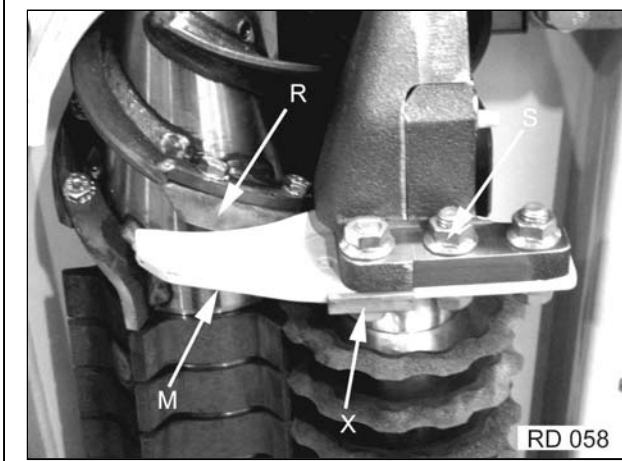

Adjustment of stubble cutters

The cutter (M) to place as near as possible to the rotating knives (R). Distance max. 1 mm.

For setting the knife (M) the row unit to turn one rotation. Pipe wrench to place on the gaps of the knife disk shaft.

After the adjustment, knife support (X) via slight knocking to drive to the knife.

Special screw (S) to tighten to max. value.



Prior to working on the machine, Diesel motor to be turned off and header secured against unwanted lowering!

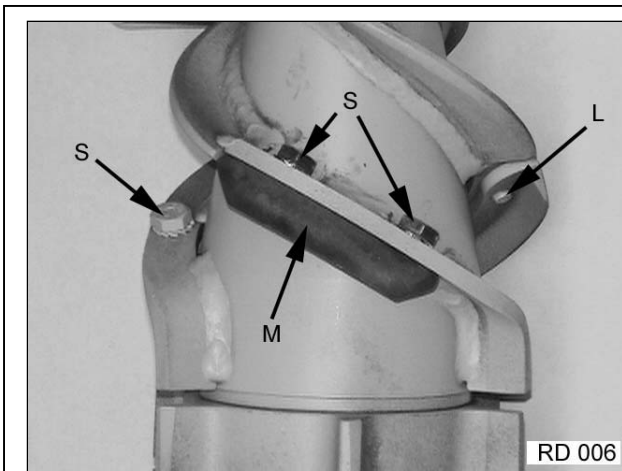

Rotor knives

Worn knives or knives with round cutting edges immediately to replace!

The rotor knives (M) to mount on level and clean surface.

Only new original special screws (S) with protection to use.

Screw thread (L) must only slightly project. Longer screws would cause the rotors to block.

The use of worn tools would increase the power demand and costs.

Only an exactly adjusted stubble cutter allows to get a good stripping performance.

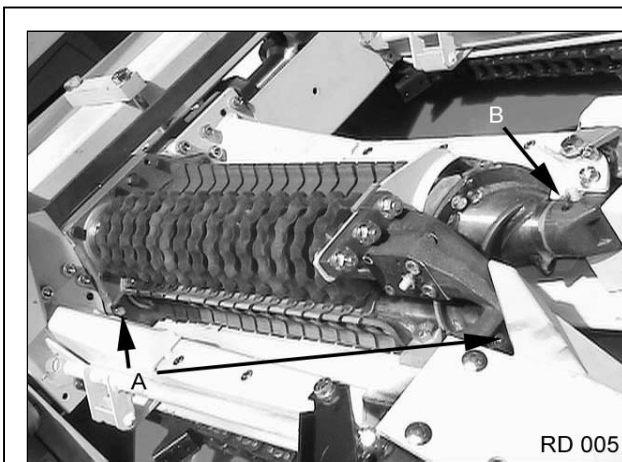

Strippers on rotors

The strippers (A) und (B) must run close to the provided area.

Distance less than 0,2 mm

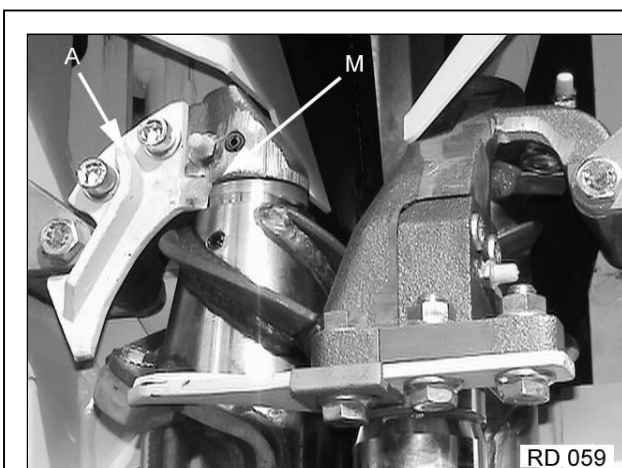

Stripper on big rotor

The stripper (A) serves to cleaning the rotor head and prevent the rotor from blocking.

The clearance within the fastening bores is great enough to allow for an adjustment according to the requirements.

The distance of the stripper nose (M) to the rotor shaft should be less than 0,2 mm.

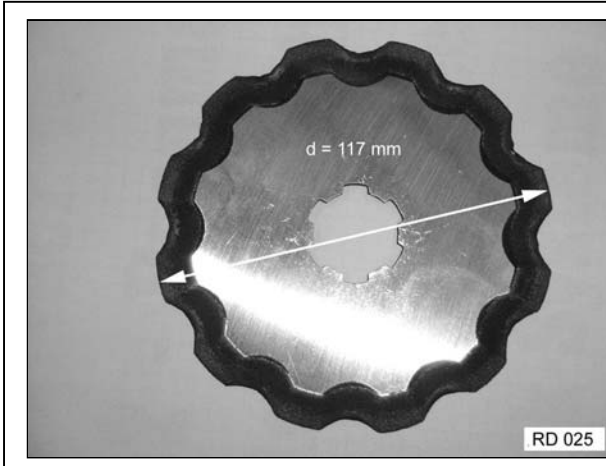

Cutting disk shafts

The frontal 4 cutting disks are the most stressed ones. The disks to replace in time to prevent the rotor working edges from further wearing.

It is recommend to replace the knife disks from a diameter of 110 mm.



When working on the machine, Diesel motor to turn off and header to be secured against unwanted lowering!

The cutting disks must deeply engage into the grooves of the rotor core. Failing which, replace them.

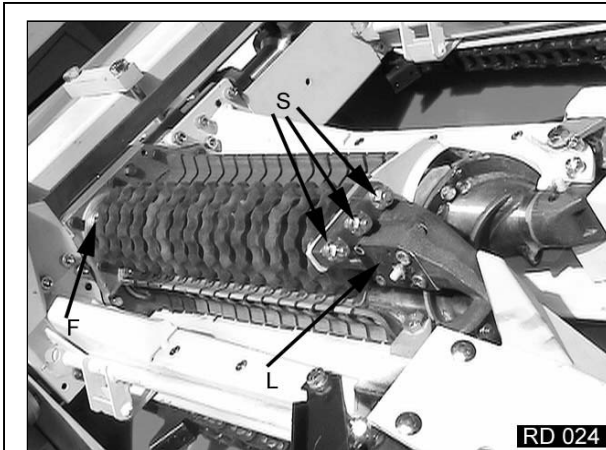

Cutting disk shaft to dismount

Fixed stubble cutter to dismount once removed the screws (S).

Screw of flange (F) to remove. Screws of bearing shell (L) to remove and bearing shell to take off.

Cutting disk shaft via mounting lever to press out of bearing and flange.



Adequate safety gloves to use!

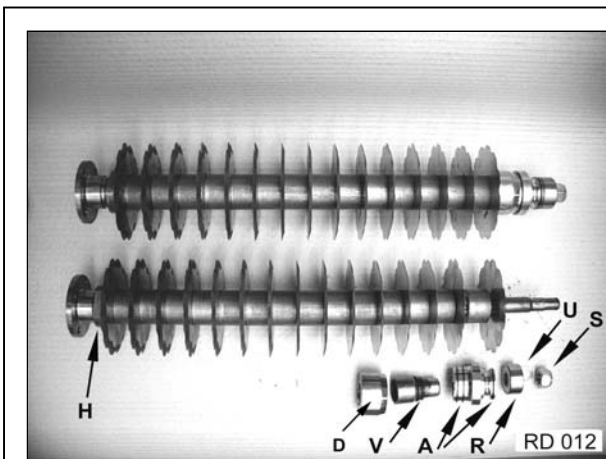

Cutting disks to replace

Nut (S) to remove. Complete bearing (D, V, A, R, U) to pull off.

Adequate tool to take for driving the cutting disks from the shaft.

New greased cutting disks to mount. Bearing to check and the not greased ball bearing (R) to mount with open side forwards.

Nut (H) to loosen for one turn. Nut (S) to tighten. Nut (H) to tighten and secure.

The axial regulation of the disk position towards the grooves can be made via the nuts (H + S).

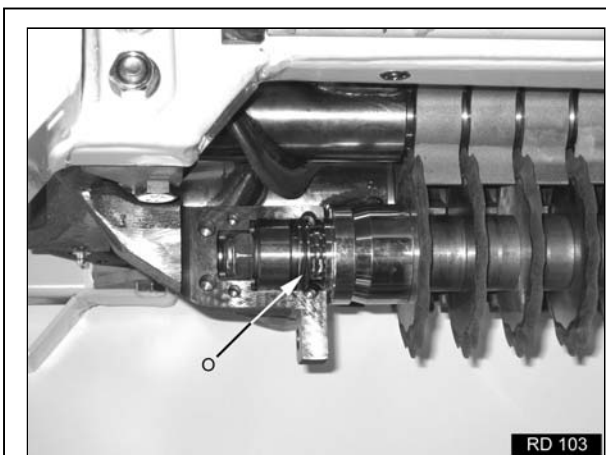

Remounting of the cutting disk shafts

Bearing shells to clean.

Cutting disk shaft first to put into the gearbox flange and then into the bearing shell half.

Bearing shell cover to put on and the O-ring (O) to check for exact fitting.

Flange only to use with original safety screws (M8 x 14 - 10.9).

Longer screws destroy the gear.

Bearing thoroughly to grease.

Check again after a short operation time.

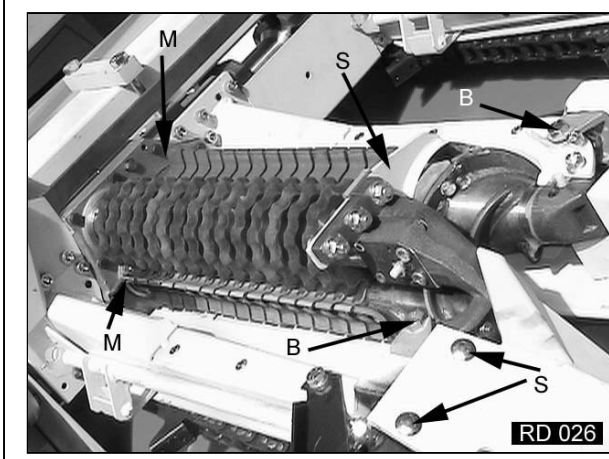

Rotors to dismount

Unscrew the skid screws (S).
 Cutting disk shaft to dismount (see page 10 / 100).
 If required, stripper on the big rotor to remove. (see page 10 / 000).
 Bolt (B) to remove.
 Complete rotor with frontal bearing holder via mounting lever in pos. (M) to pull forward off the section shaft without damaging the aluminium housing.
 When remounting, section shaft of the gear well to grease and the toothing of the rotors to check for being uniform.

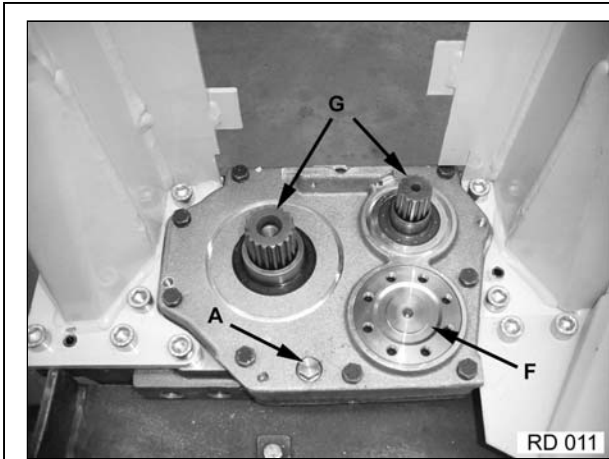

Stripping row gear

View without rotors
 Rotor shafts (G)
 Oil drain plug (A)
 Flange (F) for cutting disk shaft
 Spur gear is accessible without the need for dismounting the gear.

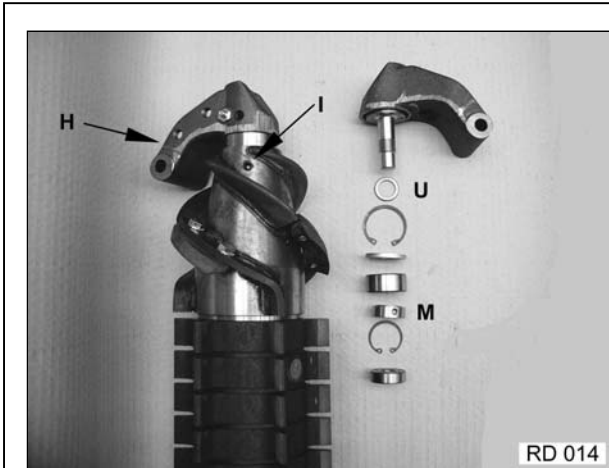

Bearing holder to take off the rotor

Stud screw (I) SW 5 to remove.
 Bearing to turn such that the stud screw with hexagon socket SW3 gets visible in the threaded bore.
 Stud screw via spanner to loosen for one left turn and spanner to remove.
 Bearing holder to turn by 180° until the bore gets visible in the set collar (M). Mandrel to put into the bore for blocking thus the set collar. Bearing holder with mandrel to unscrew to the left and pull off when set collar is unblocked.

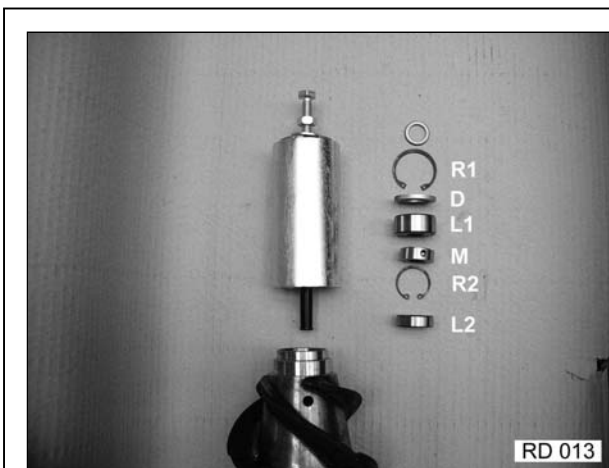

Bearing to remove from the rotor

Seeger circlip ring (R1) to remove.
 Use Geringhoff special tool, spare part 501165, for pulling out the bearing and set collar.
 Seeger circlip ring (R2) before the rear bearing to remove.
 Via special tool rear bearing to pull out.
 Remounting in reverse order .

Attention!

Special nut (M) to mount with the nose to the frontal bearing (L1)!

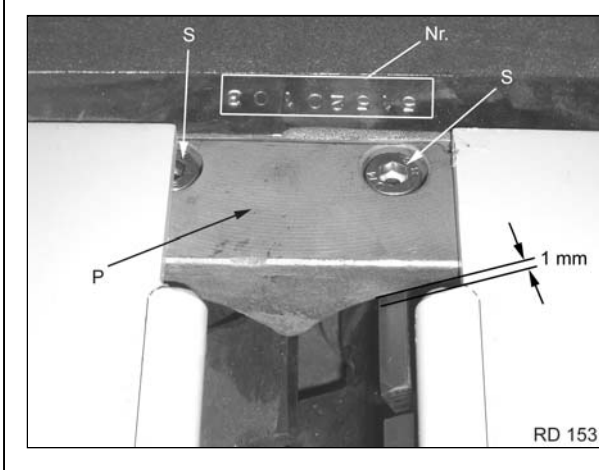

Cut-off block

The cut-off block (P) is mounted with screws (S) beneath the stripping plates in front of the gearbox.

If required, the spacing (A) to the rotors (max. 1 mm) is to be adjusted via spacers put between the cut-off block and the row unit gear.

If the spacing is more than mm, in particular on humid conditions, the rotor runs into the risk of blocking in this area.

Note: The individual number of each row unit is indicated on the pos. (no.).

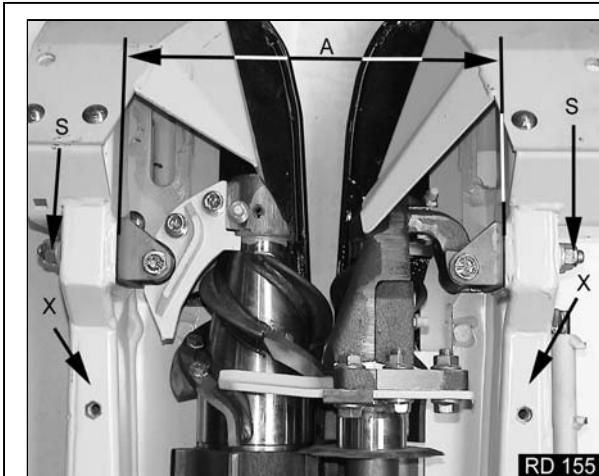

Control dimension row unit frame

The correct frame carrier spacing (X) in the frontal zone (A) is of essence for the function of the corn header.

This spacing can be changed by collisions. In particular on the outer rows (right and left) the carrying arms may become bent because there aren't further rows for support.

In the event of a collision or when starting a faulty operation of a row unit, the spacing (A) 317,5 which may vary +/- 0,5 mm, is to be checked. The variance mentioned is to be strictly maintained.

To be able to isolate which carrying arm (X) is bent, the screws (S) must be loosened at least once by hand without any harvest material building up. The resultant gap (U) indicates the bent side. Slight differences of up to 4 mm can be compensated via slotted washers put between the fork (G) and the area (F).

Attention!

If a spacer is mounted below the fork (G), the stripping plate attached must be readjusted separately to reestablish the basic setting (see page 09 / 480).

In the event of greater damage, the carrying arm in question must be aligned or replaced!

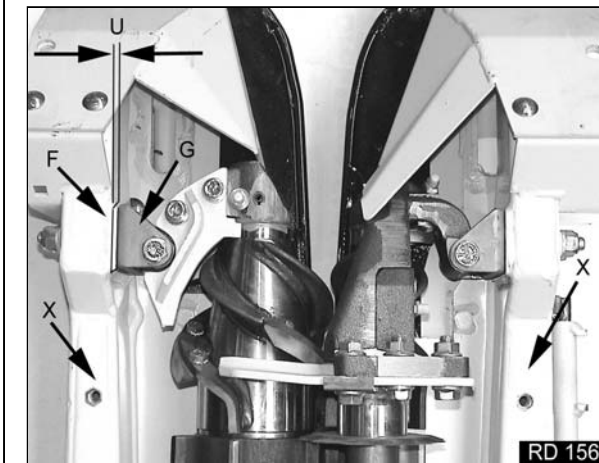

View of knife disks and rotors

It is a sure sign damage to the carrying arms of the row units if the new knife disks do not engage deeply enough into the grooves (R) of the rotors.

Apart from that, the stubble cutter does not allow for further adjustment to the counter-knives (see page 10 / 000).

The row unit absolutely must be checked.

A visual control of the row unit position for isolating any problems is insufficient.

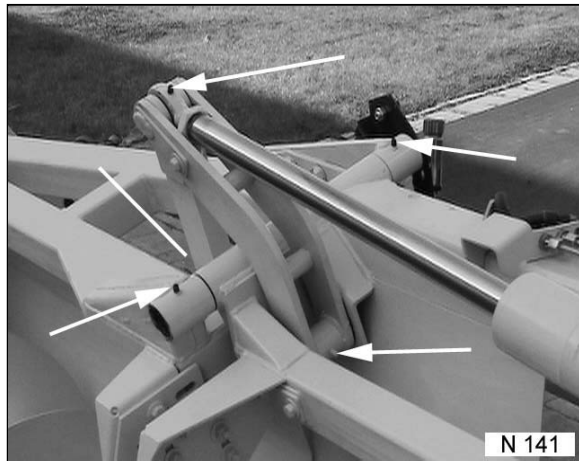

Cleaning after the harvest season

Once finished quite a dry harvest season, a dry cleaning is recommended using only compressed air.

If the machine was exposed to humidity with thus getting strongly soiled, a high-pressure cleaner should be used.

First, the shields and gathering chains to take off and all bearings lubricated.

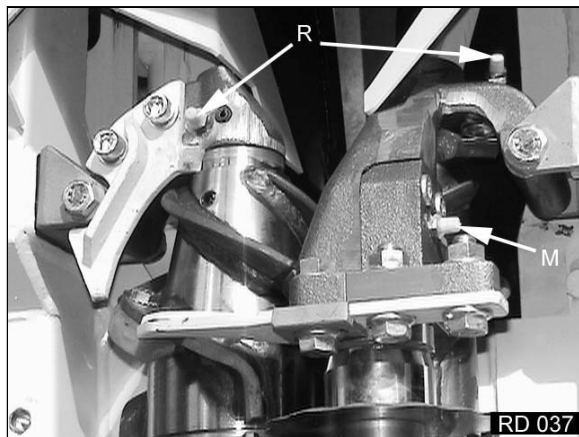

Greasing points

The greasing points are located as follows:		(hours)
Stripping rows:	on front bearing	(15)
PTO-shafts:	general	(100)
PTO-shafts:	tubes and sliders	(200)
Folding mechanisms:	joints and pivots	(100)
Shaft coupler:	sliders / flange	(200)

The brackets show the greasing intervals in hours.

After each cleaning, the machine should be greased again and put into operation for short time.

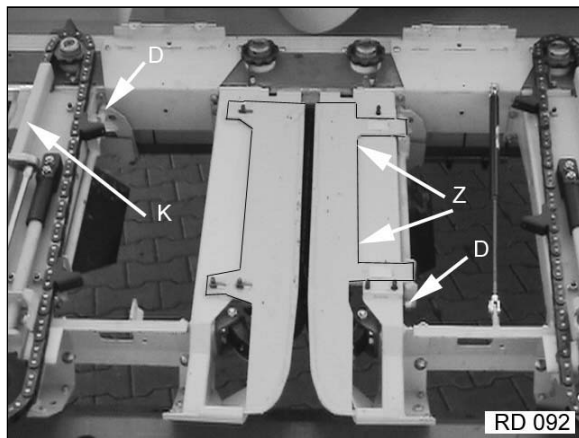

Stripping plates

When cleaning the machine, the stripping plates must be moved quite often for removing dust and corn remainders out of the pushing channels (Z).

If the machine is cleaned with water, the chain guides (K) to remove and the pushing area (Z) of the stripping plates to clean and protect against corrosion.

The pivots (D) should be oiled or greased.

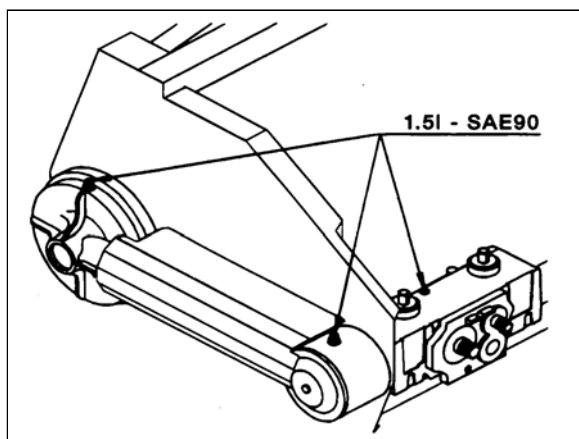

Gear (see also page 09 / 560)

Filling quantity: 1,5 l gear oil SAE 90 (commercial quality)
To fill up to the escape on gauge opening and/or according to dip stick indicator.

Change intervals: 50 h from start-up, then once before each harvest, but at latest after 200 h.

Oil drain plug (A) is fitted with magnet, which must be cleaned on each oil change.

Oil level to check !

Prior to winterizing the header, vent screws on the folding elements to be checked for tightness.

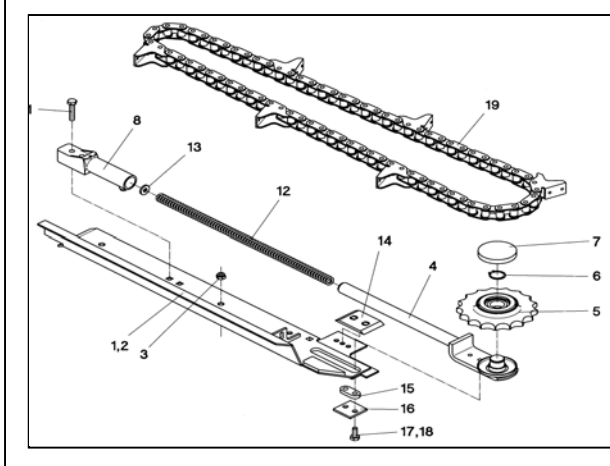

Gathering chains

Prior to winterizing the header, the gathering chains should be protected against corrosion using an adequate oil.

In the season to follow, the right and left chains should be changed to get a uniform stress.

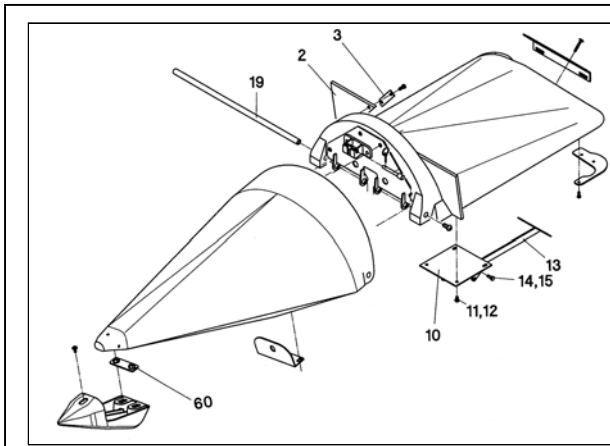

Plastic bodywork

The plastic elements do not need a special care.

However, they should be stored free from distortion if the bodywork is not mounted to the machine.

Ensure that the shield extension rubbers (2) don't get deformed.

If required, metal parts are to be protected against corrosion.

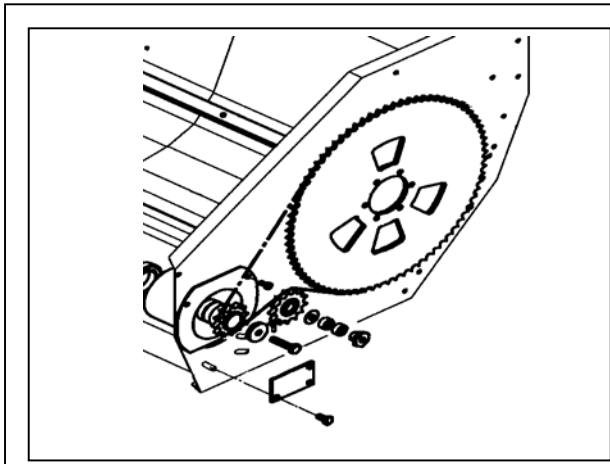

Roller chains

The only roller chain mounted for the cross auger drive must be kept rustfree when winterizing the header.

The recommendations for the roller chain care to follow.

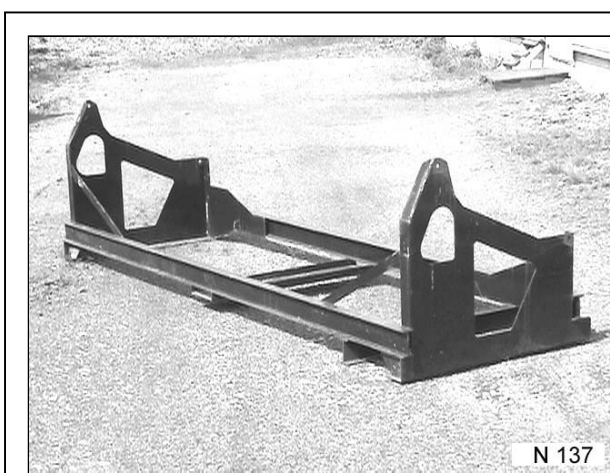

Storage

The corn header best to be stored in a well ventilated hall either upright in the transport rack or on a dry ground.

All metallic and bright parts should be protected against corrosion.

Corn header not to store in lifted state on the combine.
Prevent the combine tires from unnecessary loads.



Hydraulics

Trouble: Cause: Remedial action: Page:

Corn header cannot be lifted	Not enough hydraulic oil	Oil to refill	09/200
	Lifting force too low	Additional lifting cylinder required	09/120
Hydraulic functions of the header don't work	No flowing-through in the hydraulic connections	Connections / couplers / screwings to check	09/200
	Transport protection blocks folding process	Transport protection on 8 and/or 12-row header to remove	09/040
	Optional: Control valve does not work	Control valve to check	09/200
	Insufficient pressure of the hydraulic system	Pressure to check, if allowed to increase	Combine manual
	Locking blocks	Locking and/or reversing valve to readjust	09/240
	Not enough hydraulic oil	Oil to refill	09/200
Folding header does not close on point of separation	Foreign bodies hinder folding process	Foreign bodies or corn remainders to remove	09/240
Folding shields do not close	Locking not made	Locking and/or reversing valve to readjust	09/240
Folding shields open automatically	Control valve does not close reliably	Control valve to check, correct operation to secure	09/200
Folding process is not quick enough	Combine is possibly fitted with a throttle in the reel horizontal adjuster	If allowed, throttle to remove Hydraulic pump to check	Combine manual

Drive

Trouble	Cause:	Remedial action:	Page:
Drive is turned on but does not turn	PTO-shaft	PTO-shaft to check	09/160
	PTO-shaft coupler does not engage	Locking not made, coupling halves to check for complete engaging	09/160 09/240
	Driver of the drive coupler defective	Drivers to check	09/640
	Coupler does not engage	Alignment to check Slider to make moving	09/640 09/280
Header stops during operation	V-belt not tensioned	Drive to check	Combine manual
	Overload	Working speed to adapt	

Trouble: Cause: Remedy: Page:

Stripping unit

Header stops during the harvest	Sluggishness	Stubble cutter knife distance too great	10/000
	Stubble cutter cutting edge round	Parts to replace	10/000
	Working speed too high	To adapt	
Rotors are blocked	Stripper	Stripper to adjust	10/000
	Rotor knife screws too long	Original screw to mount	10/000
	Cutting disks worn	Cutting disks to change	10/100
Slipping clutch of the row unit does not react	Foreign bodies	Foreign bodies to remove, wearing to check	09/800
	Overload	Working speed to reduce and/or speed to increase	09/440
Straw portion too high	Stripping plates	Stripping plates to open as far as possible	09/480
	Working speed	Working speed to adapt to the conditions	
Cloggings within the row unit	Parallelism of stripping plates wrong	Stripping plates to adjust	09/480
	Gathering chains slip	Chains to replace or shorten	09/520
	Foreign bodies in or beneath the row unit	To remove, dragging maize chaff to remove	
	Speed too low	Check via monitor	09/440
	Cut-off block	Missing or defective	10/210
Maize cob losses	Speed too high	To reduce, if required	09/440
	Shield extension rubber	Missing or defective	10/500
	Cob saver	To mount in addition	10/500
	Working speed	Considerably to increase	09/360
	Outer bodywork	Increases to mount	
	Row distance	Machine to adapt to the conditions	09/000
Corn losses	Stripping plates	To adjust narrower	09/480
	Speed	To reduce, if required	09/440
	Refeeding from gathering channel conveying chain	Abdeckung oberhalb der Querförderschnecke niedriger einstellen	09/760 Combine manual
	Working speed	To increase until header is better filled with material.	

Trouble: Cause: Remedy: Page:

Stripping unit (continued)

Corn stubbles too long	Working height	Header to adjust lower, if required ground adaptation system to mount	09/360
	Stubble cutter worn	Parts to replace, if required	10/000
	Divider noses	To adjust flatter, header to put nearer to the ground	09/360
	Row distance	Not suitable	09/000
	Working speed	Speed to reduce	
Stripping plates are blocking	Dirty	Mechanism to clean, plates daily to open and close several times	10/300
	Throttle in shifting cylinder	To clean	09/440
	Hydraulic supply line	To check	09/200
	Restoring spring	To clean and/or readjust	09/480
	Basic adjustment	To check	09/480

Cross conveying auger

Cross conveying auger stops during operation	Overload	Material quantity to reduce Chaff portion too high	
	Sliding clutch responds	Foreign bodies to remove Stripper to check	09/800
	Drive	Chain and clutch to check	10/400
	Original combine splashboard mounted in front of the gathering channel	Splashboard to remove	09/080
Auger half of folding header stops	Driver clutch	Adjustment and gearing to check, axial spring-loaded half to check for function (lubrication)	09/760
	Locking of the header	Exact locking to assure	09/240
Auger ejects corn cobs out of the machine	Speed	To check via monitor	09/440
	Position of the conveying aids	Position to check via table	09/720
	Insufficient feeding	Advance to increase	

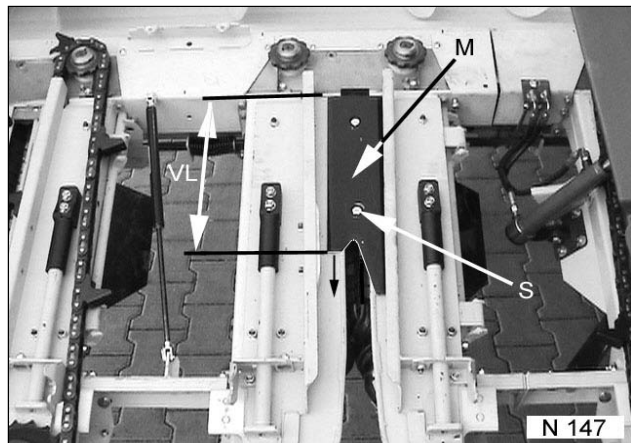
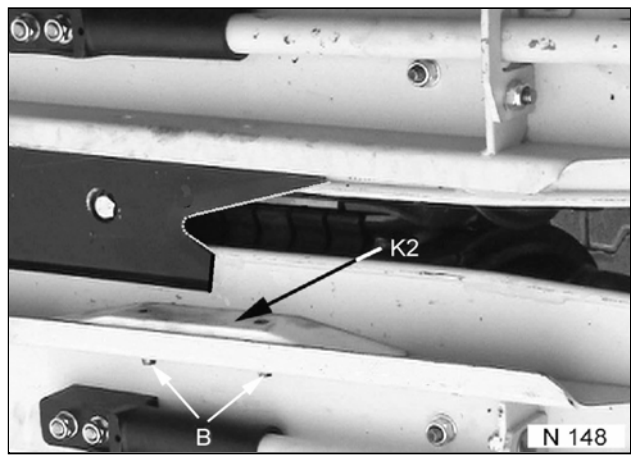
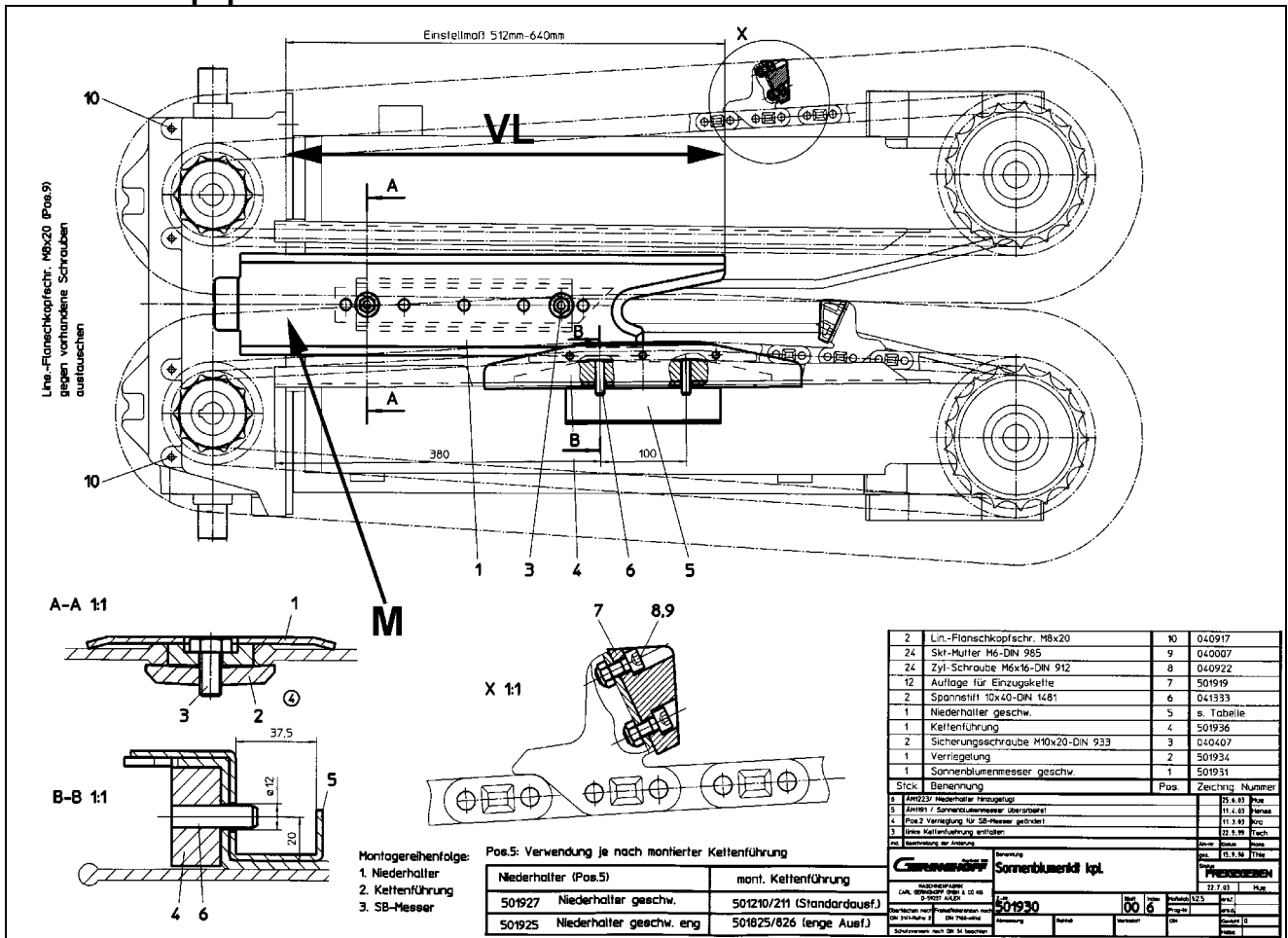

Cutter to mount

Right gathering chain to release and plastic block (4) to put in.

Holding down device for gathering chain to put on pin (5), see ill.

Stripping plates to open so much that premounted cutter (M) can be pushed in, see above graph (ill. A-A) and also (ill. N 147 M).

Size (LV) in above graph, min. 510 mm, max. 600 mm allows for an individual axial cutter setting. The more the cutter is pushed rearwards the stronger the rotors start pulling the sunflower through.

In consequence, the cutter to be pushed forwards so far that the sunflower head, if possible, won't be pushed downwards too much.

You must avoid that the head gets in touch with the chains before the stalk has been cut off.

Stripping plates to close and screw (S) to tighten.

Holding-down device for gathering chain not shown on the photos.

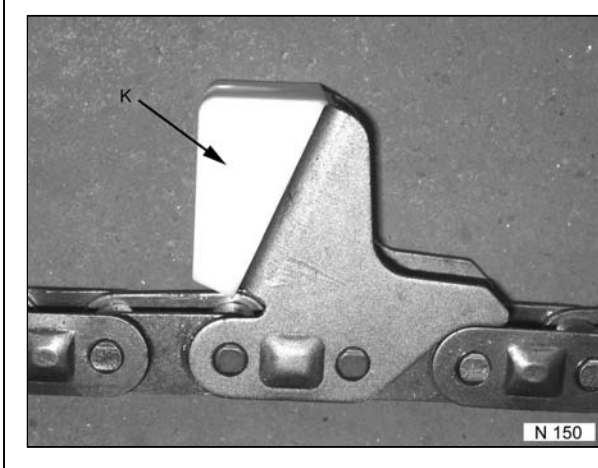

Plastic driver

To improve the material transport and due to the better feeding angle, the plastic blocks (K) as shown in the illustration, must be mounted on all chain drivers via the enclosed screws.

Attention!

For the harvest of maize, the plastic blocks (K) must be dismantled.

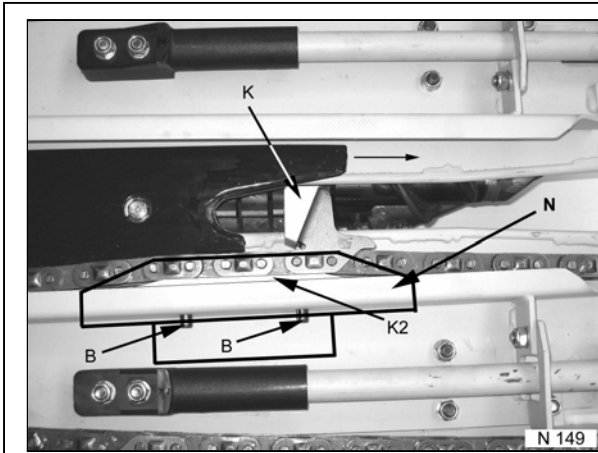

Stripping row for the sunflower harvest

The holding-down device (N) for the gathering chain is not shown on opposite illustration.

Prior to mounting the plastic block (K2), first the holding-down device (N) (see graph on page 35 / 000) to be put in behind the chain guide such that the pins (B) of the plastic block secure also the holding-down device (N).

Attention!

For the harvest of maize, the plastic blocks (K) must be dismantled again.

Ill. N 149 shows the ready sunflower series with holding-down device. (N)

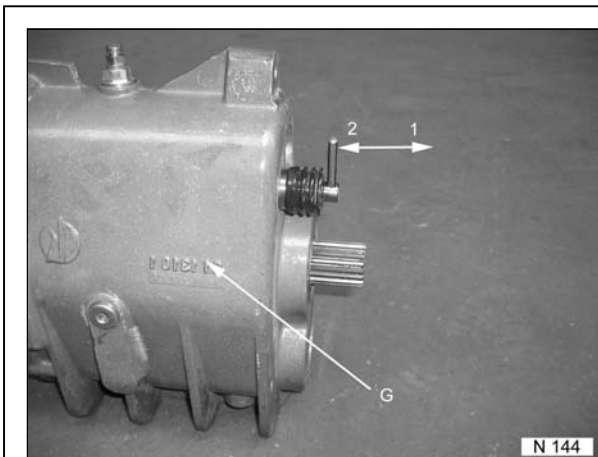

Change speed gear maize and sunflowers

To get a good function on the harvest of sunflowers, we recommend to reduce the speed to $n =$ about 470 r/min.

The 2-speed gear (G) has a fixed speed each for maize and sunflowers.

The speed is selected by shifting the lever
2 \leftrightarrow 1

5-speed gear, see page 10 / 600

Important!

For the harvest of sunflowers the working speed should be as high as possible to allow the sunflowers quickly falling rearwards into the cross conveying auger without touching the gathering chains. Check that the stalks are long enough for allowing such a procedure.

Due to the bodywork form and the real operation purpose of the header for the harvest of maize, some small corn losses cannot be avoided, in particular if the harvest material is very dry.

Attention!

The sunflower speeds must not be taken for the harvest of maize.

Gear to shift in idleness only!

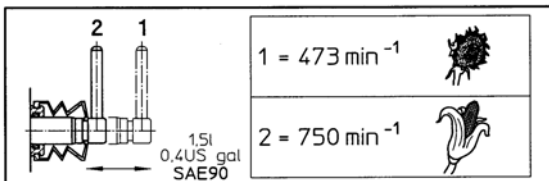

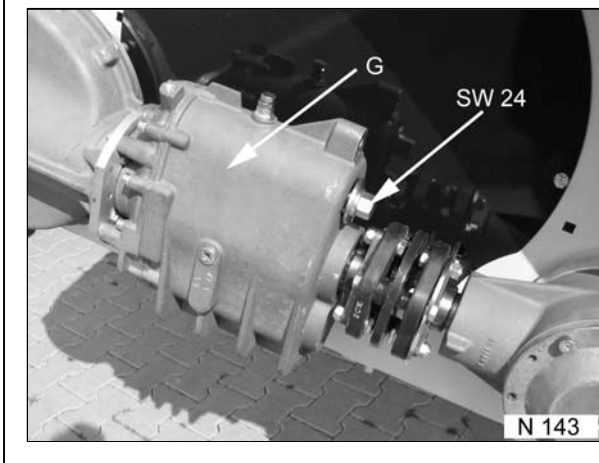

Change speed gear for speed reduction

On option, 3 different change speed gears (G) are available.

Particular harvest and harvest material may require changing the speed.

- 5 – speed for the corn and sunflower harvest
- 3 – speed only for the corn harvest

Information to the sunflower harvest, see page 35 / 000

(III. N 143 guard removed)

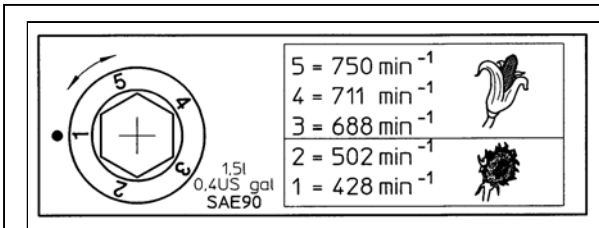

Change speed gear corn and sunflowers

5 - speed

The speed is selected via a commercially available wrench SW 24.

Attention! The sunflower speeds must not be taken for the corn harvest.

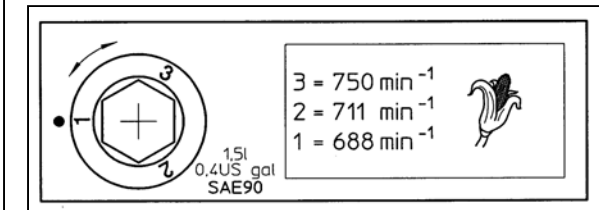

Change speed gear corn

3 - speed

Attention!
Gear to shift in idleness only!

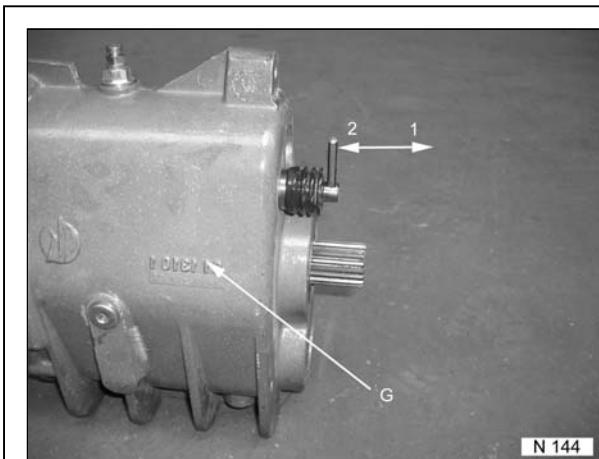

Change speed gear corn and sunflowers

The 2 -speed gear (G) has a fixed speed each for corn and sunflowers.

The speed is selected by shifting the lever 2 ↔ 1.

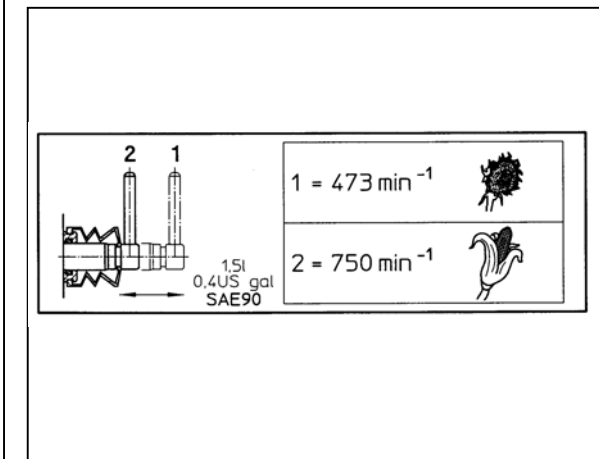

Attention! The sunflower speeds must not be taken for the corn harvest.

Attention!
Gear to shift in idleness only!

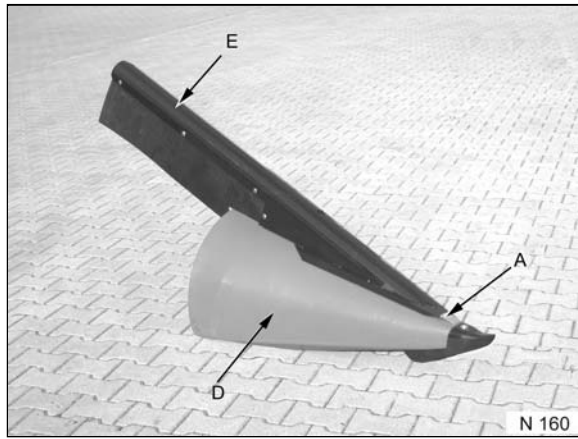

Bodywork increase laterally right and left

For sunflower and corn harvest to avoid harvest losses

Mounting instructions:

1. Bores (in front: Ø9; rear 2x11-2x Ø9) to bore via template (504286 left; 504287 right).
2. In the area of the bores, one mounting hole each from below and/or inside to bore into the outer divider nose (Ø 50-55).
3. Threaded bar (2) through the mounting hole from inside to screw down via the screws (3) to the outer divider nose (3).
4. Clamping plate (7) with 3 spacers (8) to screw down to the outer divider nose (3,12,13).
5. Outer divider nose extension with the frontal nose to push under the clamping plate so that the welded screw in the rear area engages into the pocket of the threaded bar.
6. Outer divider nose increase and threaded bar to screw down to each other (4,5,6).
7. Covering rubber to mount (9,10,11,12).

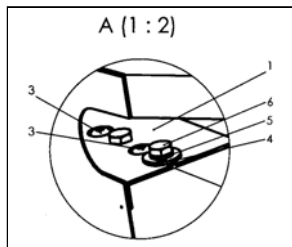
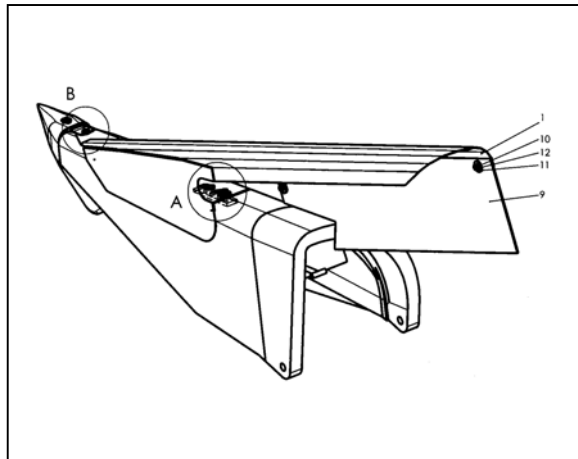

View A

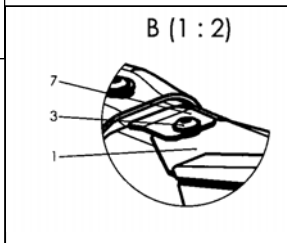

View B

1	washer 8,4 DIN 9021	13	040216
5	hexagon nut M8-DIN 985	12	040008
4	washer V9-DIN 440	11	040300
4	saucer-head screw M8*16-DIN	10	040612
1	covering rubber	9	504297
3	washer A8-DIN 125	8	040201
1	clamping plate	7	504298
1	hexagon screw M10x30 DIN	6	040438
1	spring ring A10-DIN 9021	5	040109
1	washer 10,5-DIN 9021	4	040217
3	flat mushroom head screw 8x20	3	040917
1	threaded bar	2	504299
1	outer divider nose increase l+r	1	504290/291

Bodywork increase

Order no.: 504288 (links)
Order no.: 504289 (right)

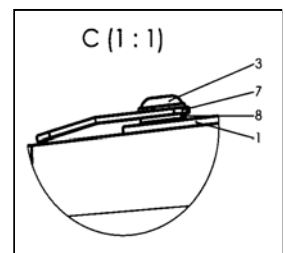
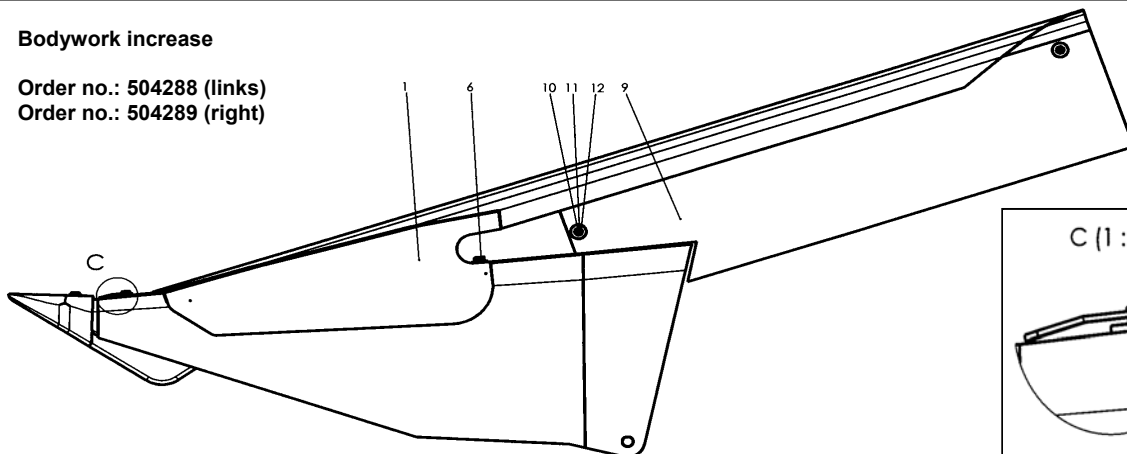

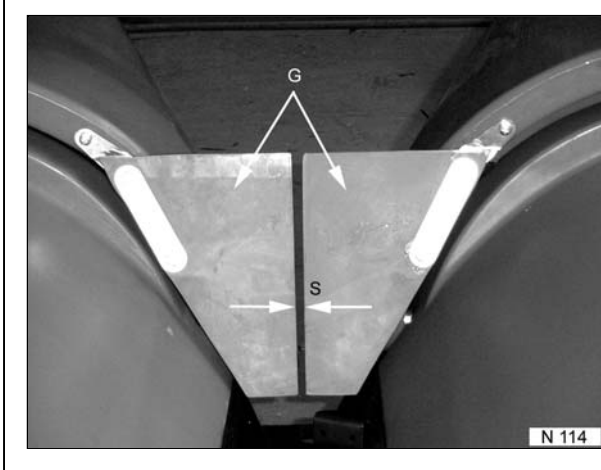

Shield extension rubber

If the maize plants are thin or even crumbly, the shield extension rubbers (G) can be screwed off.

There is also the chance of extending the gap (S) according to the conditions by removing a uniform piece each right and left.

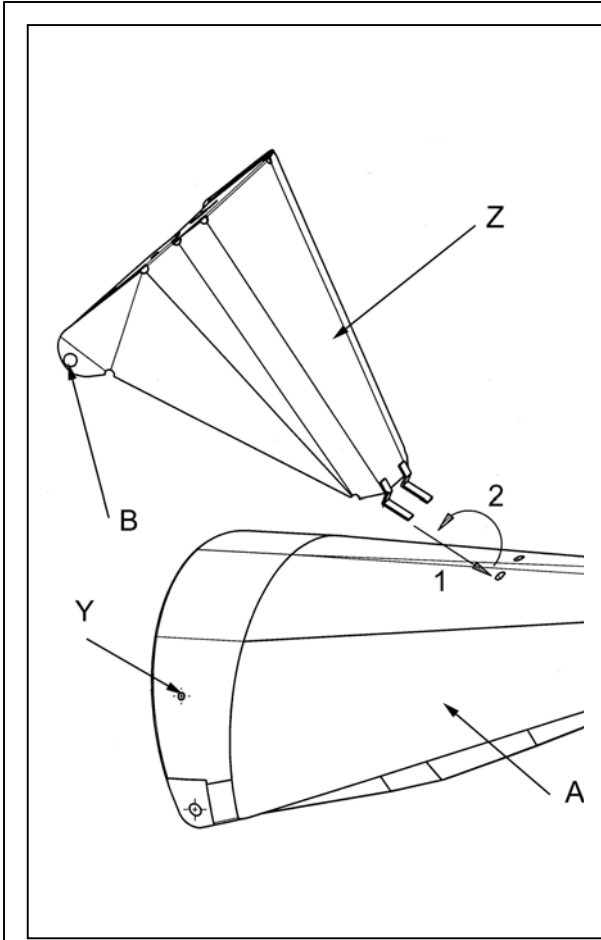

Additional cob saver (optional)

Additional cob savers are available for being put onto the center divider noses.

Certain maize sorts can produce cob losses, which requires using this additional device.

Once drilled the respective bores into the existing divider noses (see graph hereunder) the cob saver can simply be slipped on. As shown in ill. N 114, they are also fitted with the respective rubber flaps (G).

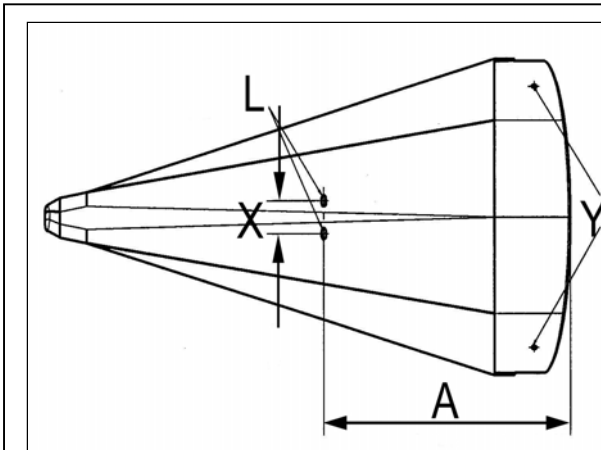

Top for reducing cob losses

According to opposite graph bores are to be drilled for mounting the additional cob saver.

- A = 500 mm
- X = 60 mm at a row width of 70 cm
95 mm at a row width of 75 cm
- Y = 11 Ø after adaptation of the top
- L = oblong holes 20 x 10 mm

Special tools

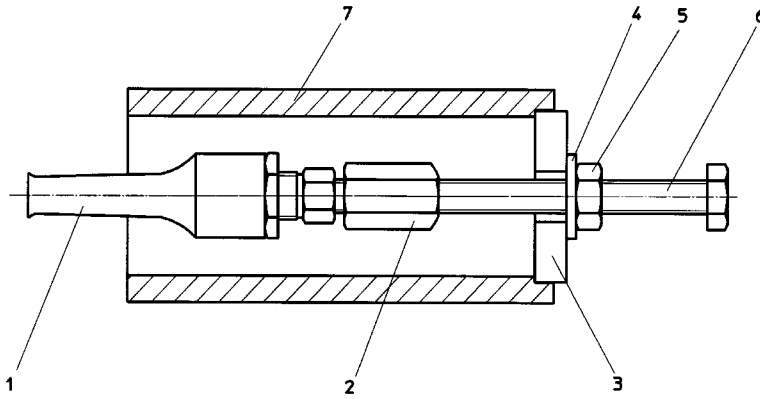

Dismounting tool
Order no. 501165

Mounting instructions:

1. Pos. 5 to screw on pos. 6
2. Pos. 4 to slip on pos. 6
3. On thread of pos. 1 and 6 medium hard Lactite to apply
4. Pos. 1 and 6 to screw down via pos. 2

1	withdrawal sleeve	7	501166
1	hexagon screw M10xW0 DIN 933	6	040476
1	hexagon nut M10 DIN 934	5	040015
1	washer DIN 125 A 10,5	4	040202
1	washer with groove	3	501167
1	extension nut 3 D hoch	2	x
1	internal puller KUKKO U-19	1	501168
Pce	Designation	Pcs	Drawing num.
0			
Ind.	Bezeichnung der Änderung	Änderung	Änderungsdatum
		Benennung Dismount tool for front bearing RD	
HASSENWERKZEUGE CARL GERINGHOFF OHG & CO KG D-59227 ARLIN		Status IN BEARBEITUNG	
Überlätzchen nach Franchöleran nach DIN 3141-Reihe 2 DIN 7168-Mittel		Zahl	Index
Schutzvermerk nach DIN 34 beachten		501165	0
Abmessung	Formel	Material	DIN

Bearing dismounting

1. Puller on ball bearing to coutertension
2. Withdrawal sleeve to slip on auger head
3. Washer with groove to slip on
4. Hexagon socket to hold fast
5. Ball bearing with hexagon nut to pull off

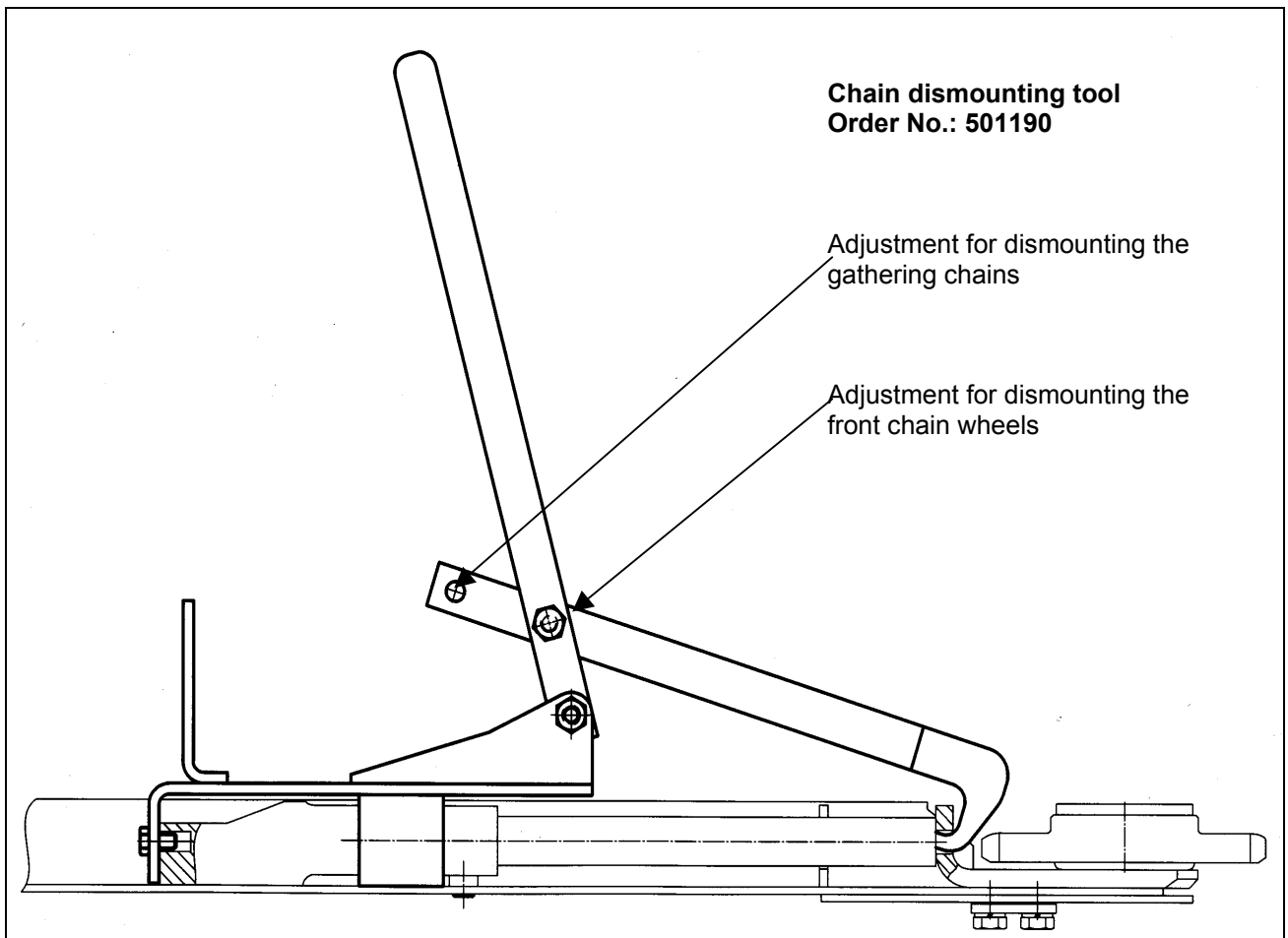

**Chain dismounting tool
Order No.: 501190**

Adjustment for dismounting the gathering chains

Adjustment for dismounting the front chain wheels

Minimum starting torque for screwing grade II in conformity with 1c

Current for bolts

Dimension size	M rated in Nm	M rated in Nm	M rated t in Nm
	degree of firmness 8.8	degree of firmness 10.9	degree of firmness 12.9
M4	2,7	3,8	4,6
M5	5,4	7,6	9,1
M6	9,2	13,0	15,5
M8	22,0	31,0	37,5
M8 x 1	24,0	33,5	40,0
M10	43,5	61,0	73,5
M10 x 1,25	46,0	65,0	77,5
M10 x 1	50,0	70,0	84,0
M12	76,0	106,0	127,0
M12 x 1,5	79,0	111,0	133,0
M12 x 1,25	82,5	116,0	139,0
M14	120,0	168,5	202,0
M14 x 1,5	130,0	183,0	219,0
M16	187,0	262,0	314,0
M16 x 1,5	198,0	278,0	333,0
M18	257,5	362,0	433,0
M18 x 2	272,0	382,0	457,5
M18 x 1,5	287,0	403,0	483,0
M20	362,5	509,0	610,0
M20 x 2	381,0	535,0	641,0
M20 x 1,5	400,0	562,0	673,0

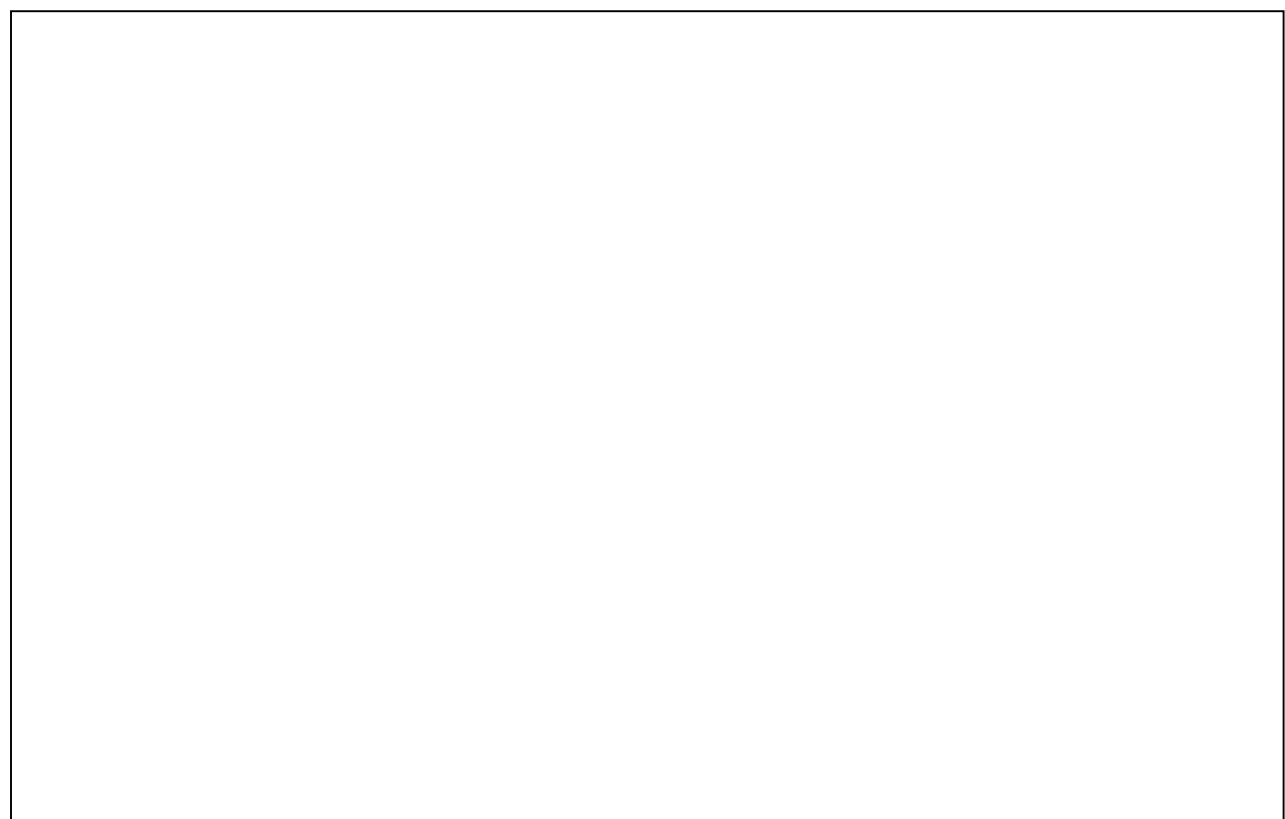

Hydraulic circuit diagram for foldable headers from 6 – 12 rows

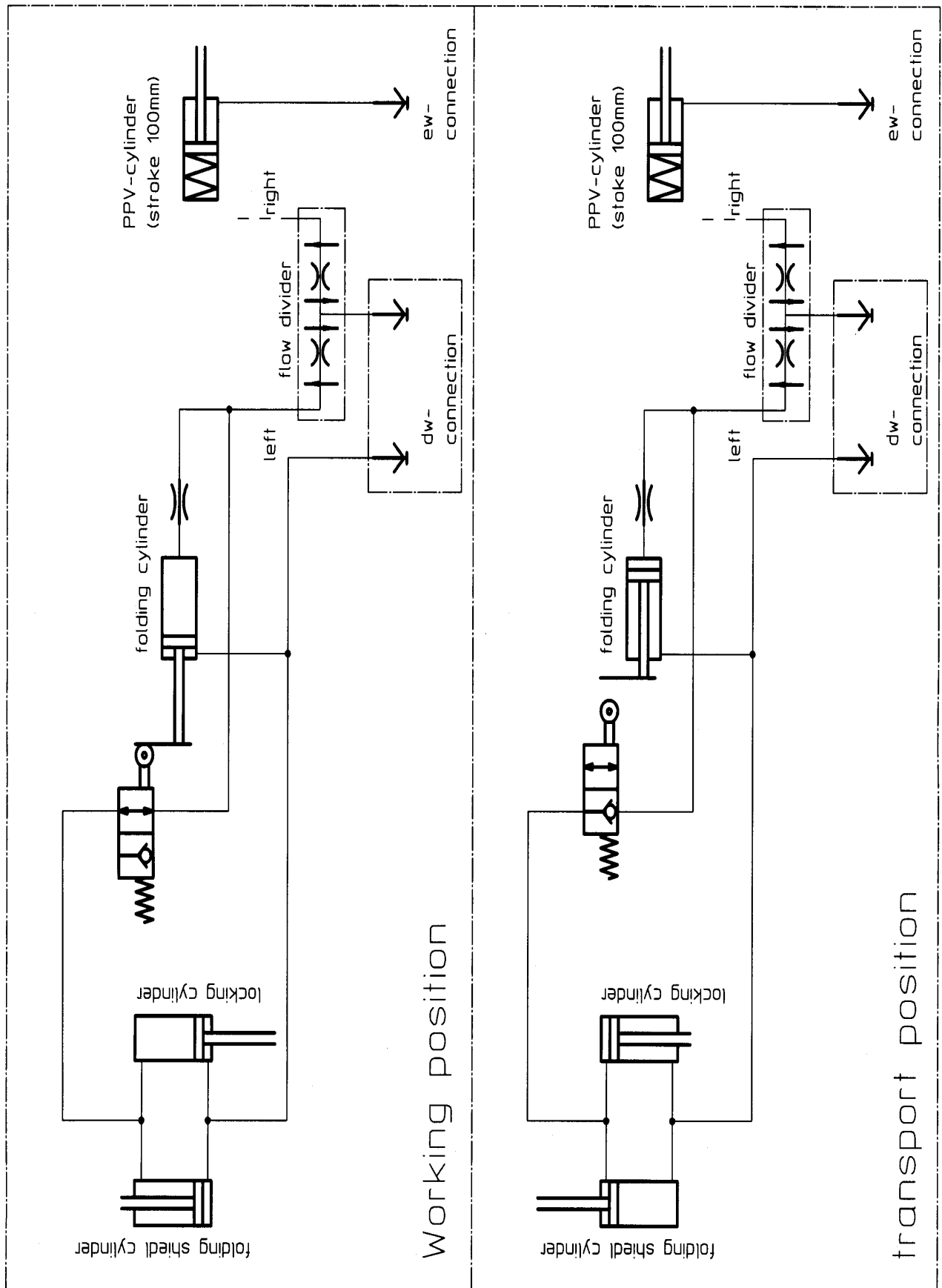

In case of queries or possible troubles on the hydraulic control of the corn header, please get in touch with our customer service at: Phone no. ++49-2382-981452 Fax ++49-2382-981456

Attention: Prior to working on the mains battery to be disconnected

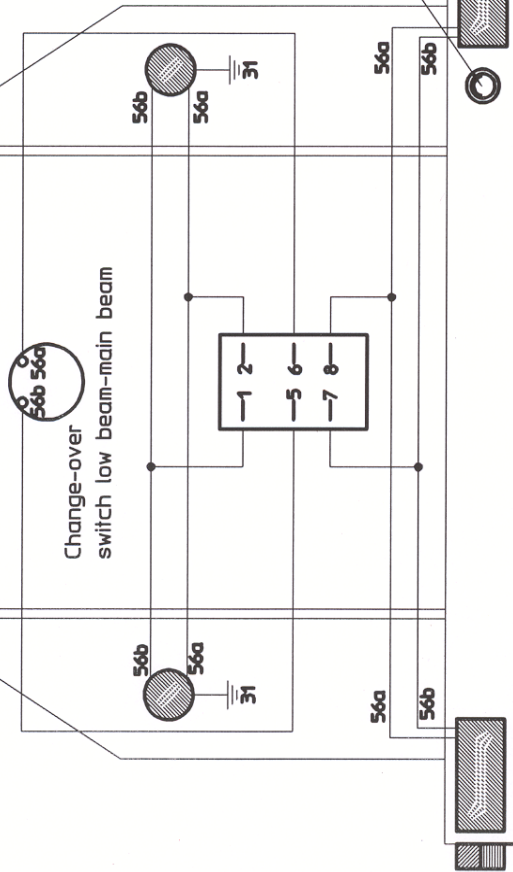

7-pole socket

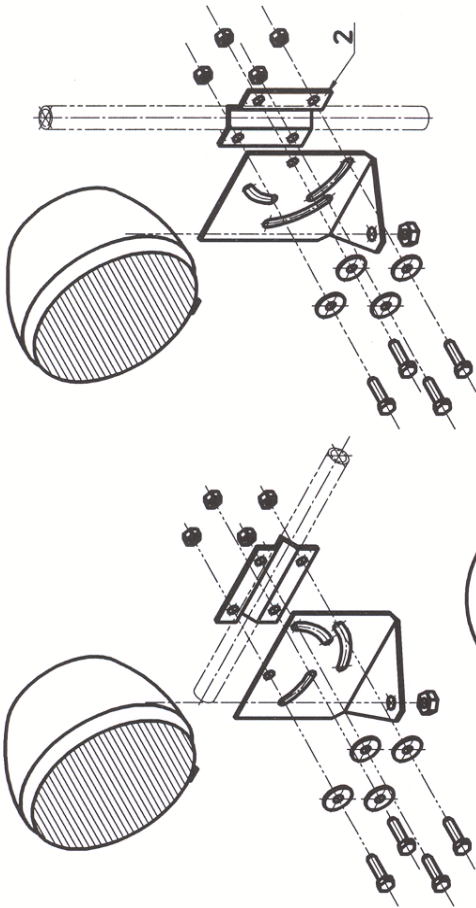

2	2 cable 3x1.5mm ² 4.3m	026558
1	1 change-over switch	9 026528
1	1 socket 7-poles	8 026524
8	8 hexagon nut SM8	7 040008
8	8 hexagon screw M8x30	6 040528
8	8 washer A8.4 DIN 9021	5 040216
1	1 horizontal holder	4 026577
1	1 vertical holder	3 026576
1	1 vertical holder	3 026575
2	2 clamping plate	2 026574
2	2 auxiliary headlamp	1 026572
Pce.	Item	Pos.
		Drawing no.

Ind. Beschreibung der Änderung		AK-Nr.	Datum	Name
		gez.		
		Status		
GERINGHOFF				
Item mounted set for headlamps for all combine types				
MASCHEINENFABRIK CARL GERINGHOFF GmbH & Co KG D-59227 ALEN				
Z-Nr.				
Oberflächen nach Fremdatoleranzen nach DIN 3141-Reihe 2				
DIN 7468-mittel				
Schutzvermerk nach DIN 34, beachten				
Blatt	Index	Material	Verstärk.	Blatt
		1:5		
Anmessung		Rohteil	DN	Gewicht
				Halbz.

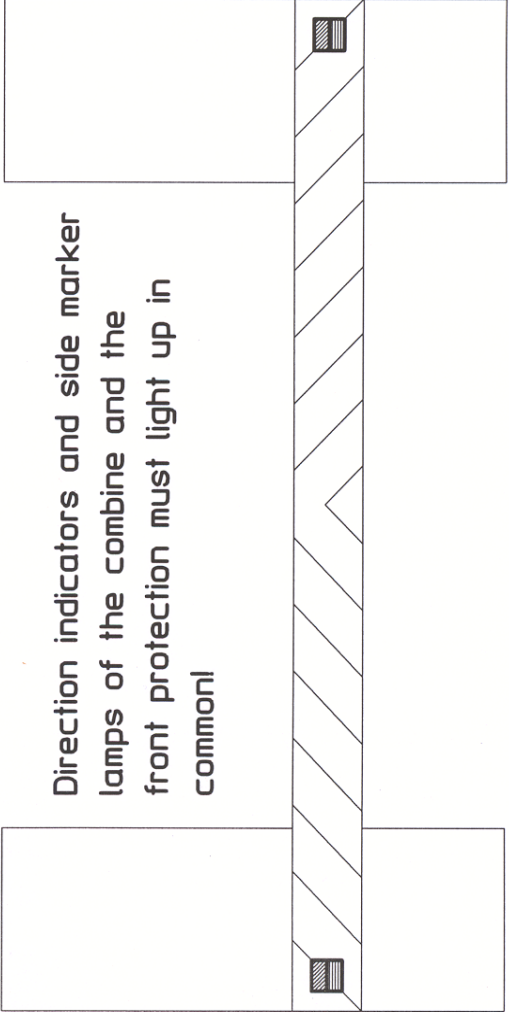

Direction indicators and side marker lamps of the combine and the front protection must light up in common!



Changes on the CNH combine gathering channel

Before mounting a header to the CNH-combine of the series CX and CR it is a must to remove the brackets (L) of the upper arm location.

Attention !

Only the brackets to remove, since the other mechanism forms the swivel of the pivoting shield!



Channel view: Brackets removed

Flat steel with screws (S) must be left on the machine.

Holder for upper arm location

To allow for a later use of the upper arm location, an additional part no. 550900 is supplied along with the machine.

This additional part is screwed on the existing bracket with longer screws (M16 x 50).

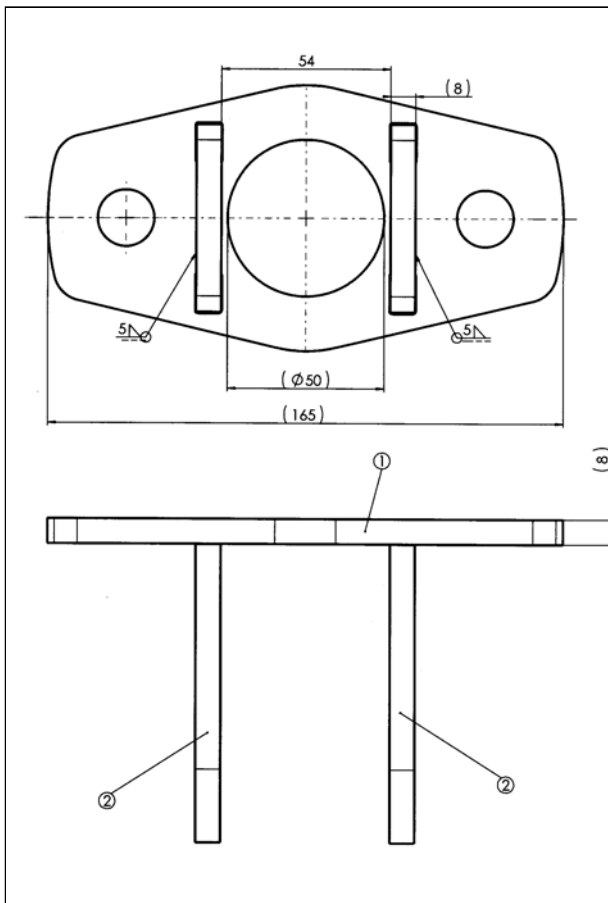

Holder for upper arm location

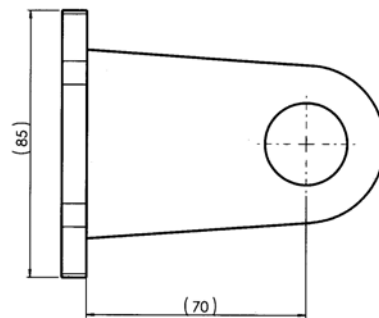

Do not weld in the area of the bore

2	Halter	QSIE 380 TM	1543	2	550902
1	Grundblech	QSIE 380 TM	1543	1	550901
MENGE	BENENNUNG	WERKSTOFF	DIN	POS	ARTIKELNUMMER

0				22/04/2002		SR	
Beschreibung der Änderung		Benennung		Datum		Name	
		Winkel f. Schrägförderer geschw.		22/04/2002		SR	
MASCHINENFABRIK CARL GERINGHOFF Söhne & CO KG 52377 AACHEN		Anbau NH-CX		22/04/2002		SR	
Überfließen nach DIN 5141-2		Nennschichthöhe nach DIN 1541-10/11		Maßstab 1:1		Zeichner m.w.k.	
Schweißmaß nach DIN 1541-10		Abmessung		Material		Gewicht in kg	

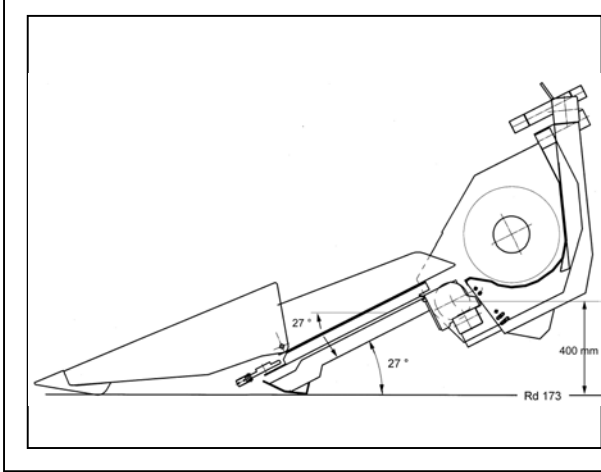

Setting angle Geringhoff *Rota - Disc header**

The ideal working angle for the Rota-Disc header is about 27°.

When converting the header from one combine make to another one, in general new adapter parts are required.

When changing from a rigid, not foldable header from the series JD 22.... to WTS, CTS or STS, that could be done without the need for using new adapter parts.

That does not apply to „Hillmaster“ versions

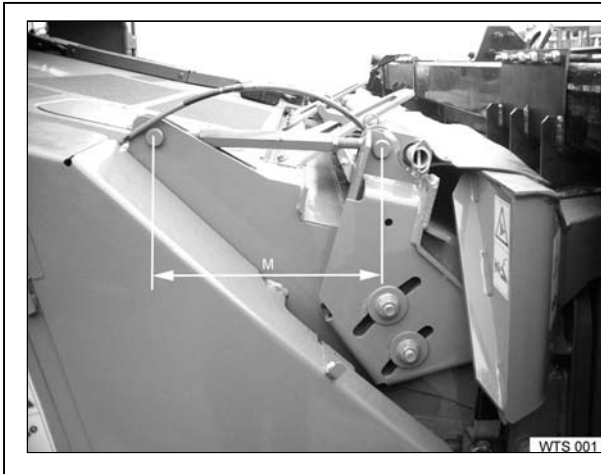

John Deere WTS, CTS and STS combines

If a not foldable corn header is provided for the series JD 22.... to WTS, CTS or used to STS, the channel angle (M) is to be adjusted to the lowest possible size (M).

This adjustment allows approaching to the required working angle of the corn header Rota-Disc.

A further adjustment of the working angle of the header can be made via the standard angle adjustment of the header (see also 09/480).

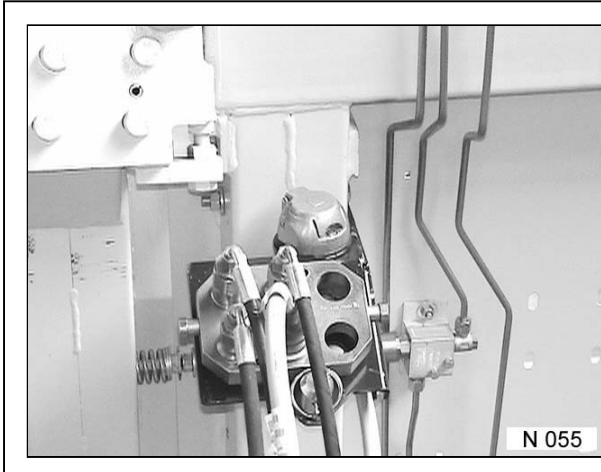

Multicoupler for hydraulic connection

Combines of the series WTS, CTS and STS are fitted with a multicoupler for the hydraulic connection to the header.

This coupler must be provided along with the adapter parts for being able to operate the header.

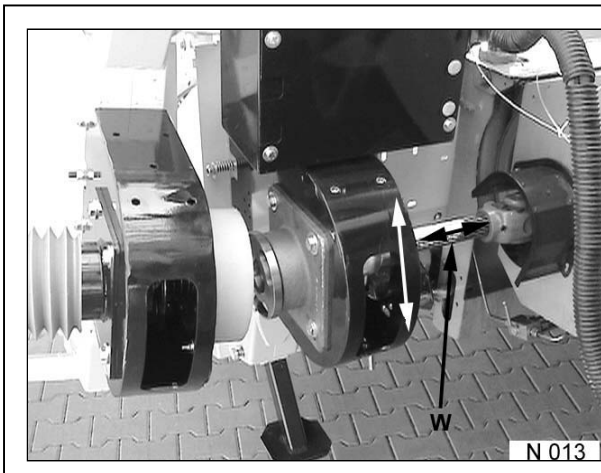

Conversion of folding *Rota-Disc headers from JD 22... to John Deere WTS, CTS or STS**

These changes require in any case using new adapter parts, since the PTO-shaft coupler requires an exact adaptation of the driving point.

New adapter parts are also required when changing from series JD 22.. to WTS, CTS or STS on „Hillmaster“ versions.

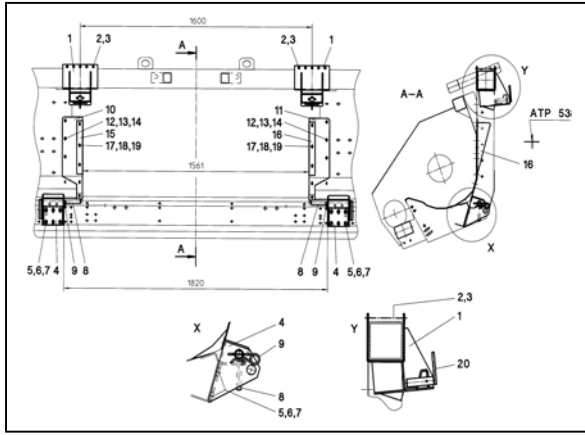

Feed opening of the corn header

Certain opening sizes of the header for all combine makes and models are determined for the feeding to the gathering channel of the combine.

The exact opening width to be learnt from the sketches in the spare part catalogue from picture table 60/...

For standardization reasons, slight variations from the rated size are allowed.

In particular when working on slopes a regular feeding is of essence for the harvest material to be distributed evenly within the machine.

gültig für Europa Varianten:
 9540,9560,9580
 9640,9660,9680
 9780
 9880
 1450,1550-SF-Europa

Stück	Benennung	Pos.	Zeichng	Nummer
1	Dichtgummi 16x8x455	20	553176	
2	Ski-Mutter M8-DIN 985	19	040008	
4	Scheibe A8 4-DIN 125	18	040201	
4	Ski-Schraube M8x20-DIN 933	17	040444	
6	Ski-Mutter M8-DIN 985	16	040008	
6	Scheibe V9-DIN 440	15	040300	
6	Flachr-Schr. M8x20-DIN 603	14	040437	
1	Bodenblecherw. rechts	13	553171	
1	Bodenblecherw. links	12	553170	
6	Ski-Mutter M12-DIN 985	11	040010	
6	Scheibe A13-DIN 125 verz.	10	040203	
6	Ski-Schraube M12x30-DIN 933	9	040496	
1	Verriegelungsplatte rechts	8	553181	
1	Verriegelungsplatte links	7	553180	
10	Ski-Mutter M12-DIN 985	6	040010	
10	Ski-Schraube M12x25-DIN 933	5	040427	
1	Anlageblecherweiterung geschw.	4	553160	
8	Ski-Mutter M12-DIN 985	3	040010	
8	Ski-Schraube M12x150-DIN 931	2	040505	
2	Adapter geschw.	1	553150	

3	Varianten um 1450,1550-SF-Europa erw.		2.6.03	Lko
2	Bezeichnung geändert		11.4.02	Plus
1	1053/Adaption kpl. überarbeitet, ATP 62 neu		17.4.02	Hense
ind	Reschreibung der Änderung	An-Nr.	Datum	Name
		gez.	17.4.02	Hense

		Benennung Adaptionsatz - RD JD 9540-9880, 1450/1550		Stück FREIGEGEBEN	
MASCHINENFABRIK CARL GERINGHOFF GmbH & Co KG D-59227 ARLEN		Z-Nr.	00 3	Multistab 1:10	erst
Oberflächen nach Feinblättern nach DIN 3141-Reihe 2		Abmessung		Prop-Nr.	erst
Schutzvermerk nach DIN 34 beschriften		Material		DIN	Gewicht 0
					Masse

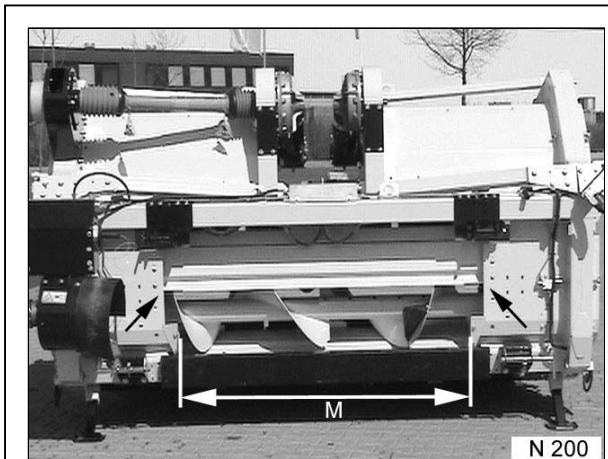

Adaptation to combine width

If the corn header is changed between different combine makes and types, it must possibly be adapted to the different machine width.

The plates (12 and 13) are to be put to the required size to ensure a homogenous machine feeding.

The width (M) of the header opening is to be adapted to that of the combine.