

GASPARDO

PARTI DI RICAMBIO

Scheibengrubber



Rahmen SG-M 522- 626- 730
Rahmen SG-M 730 S
Rahmen SG-M/H 938-1355

Zinken und Schare
Federsteinsicherung
Zudeckscheibe
Scheibenthalter '98
Randscheiben

Rohrwalze
Spiralwalze
Doppelwalze

Goliath

Typ

Baugruppe

Scheibengrubber

Rahmen SG-M 522-626-730

SG-M 522 - 626 - 730

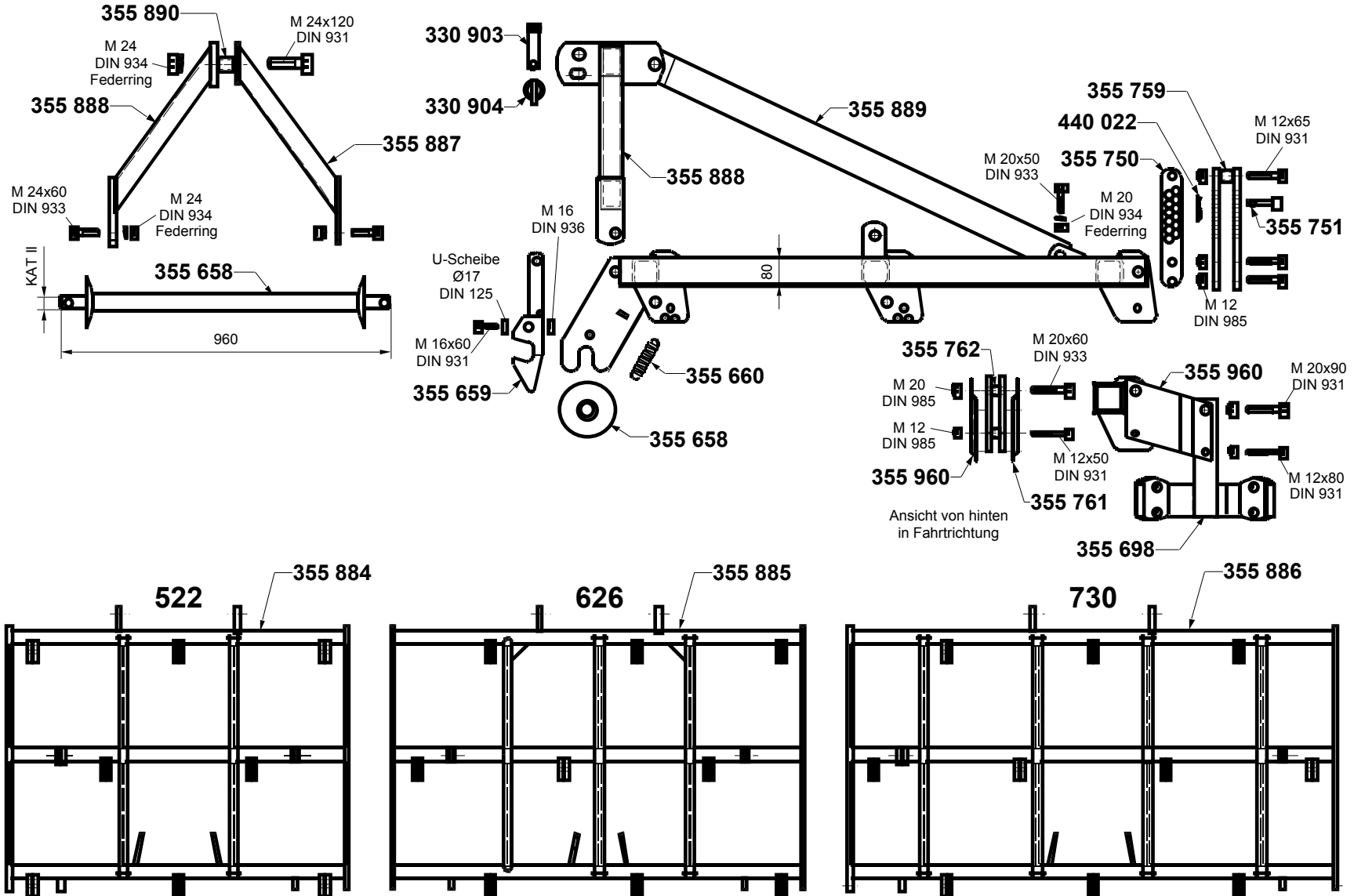

Typ

Baugruppe

Scheibengrubber

Rahmen SG-M 730 S

SG-M 730 S

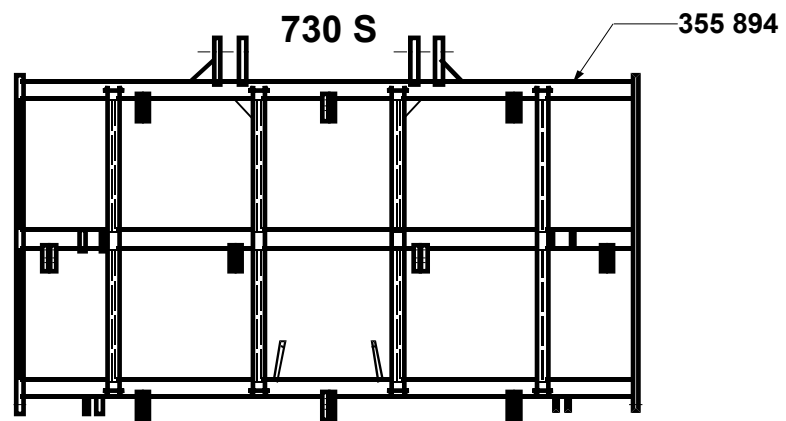
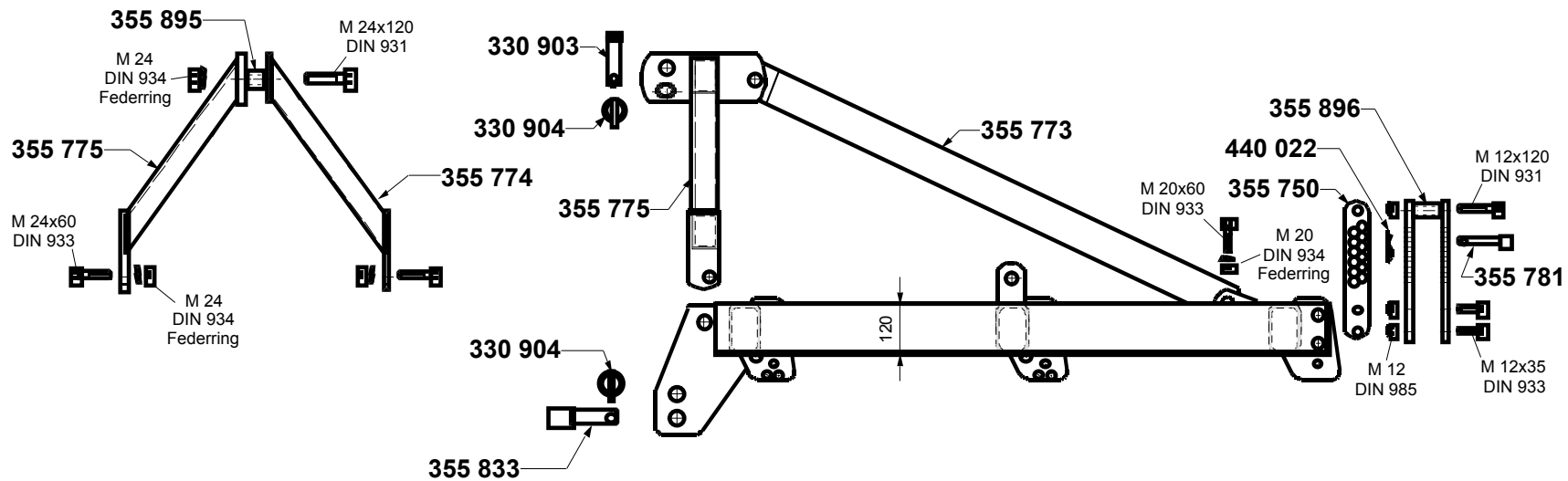

Typ

Baugruppe

Scheibengrubber

Rahmen SG-M/H 938-1355

SG-M/H 938 - 1146 - 1355

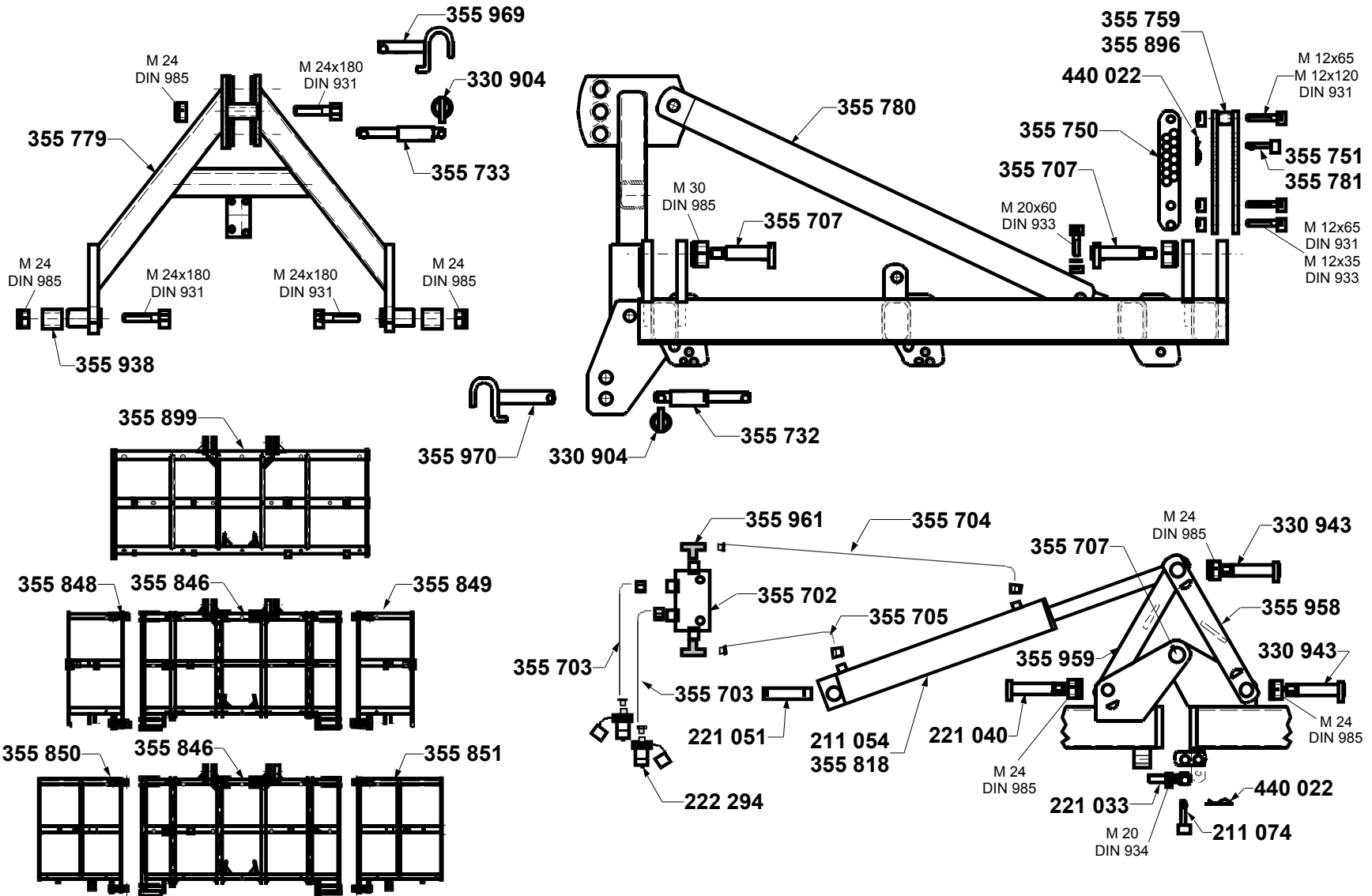

Typ

Baugruppe

Scheibengrubber

Zinken - Schare

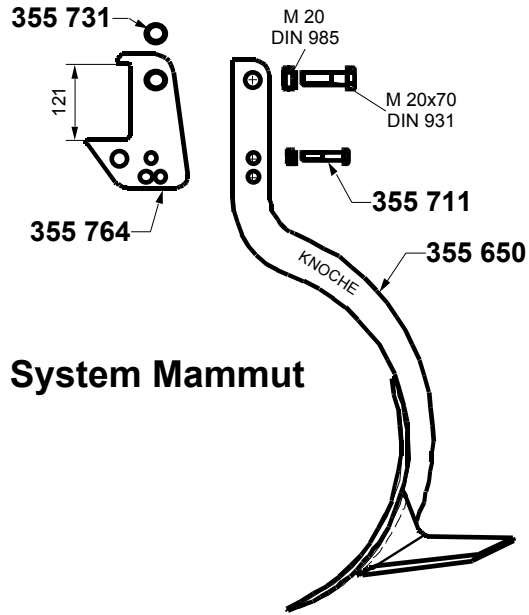

System Mammut

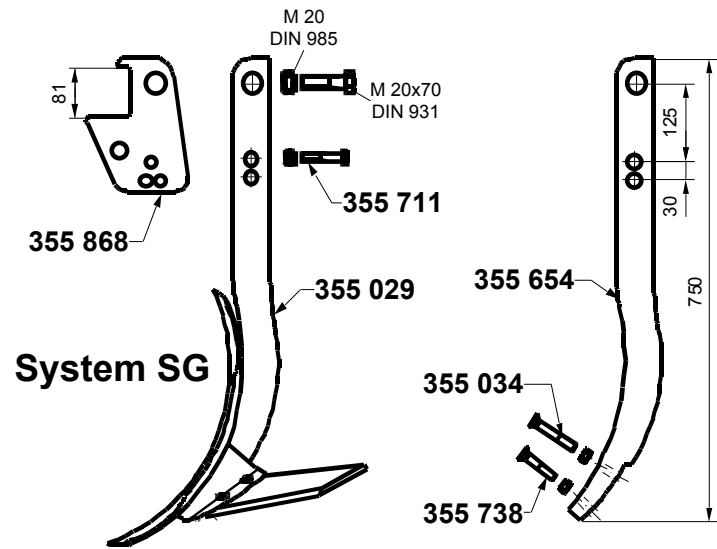
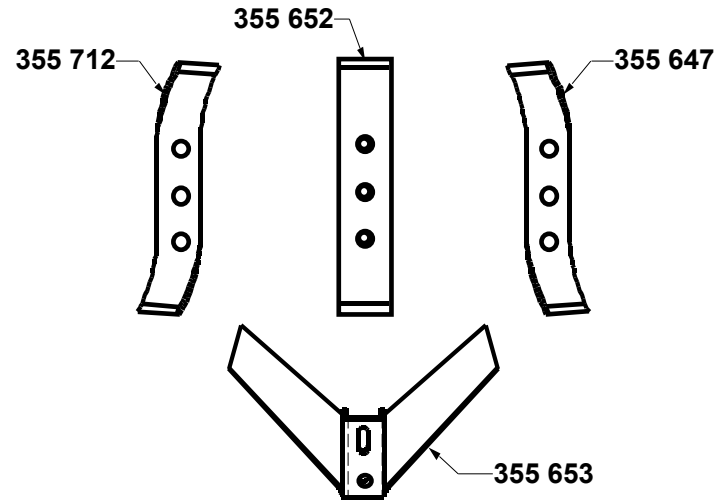
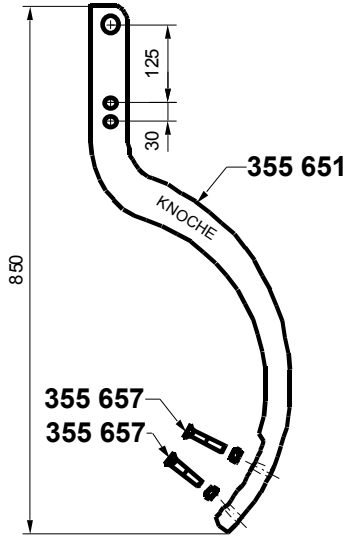

System SG

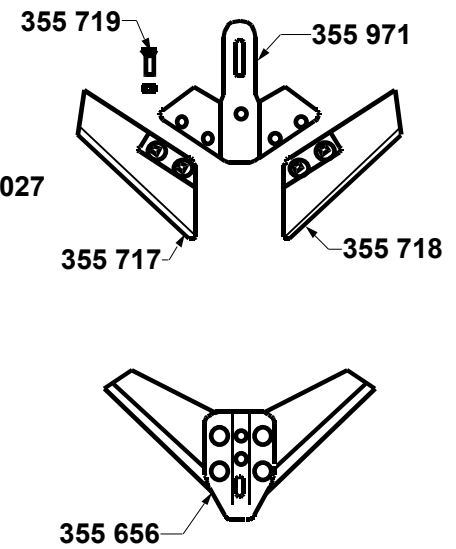
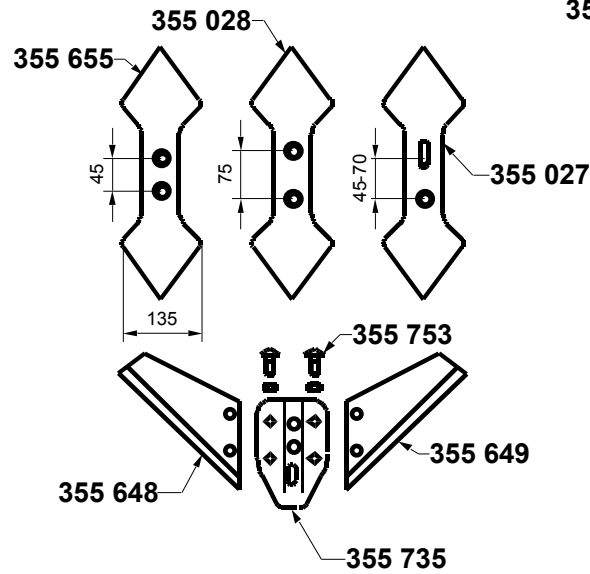
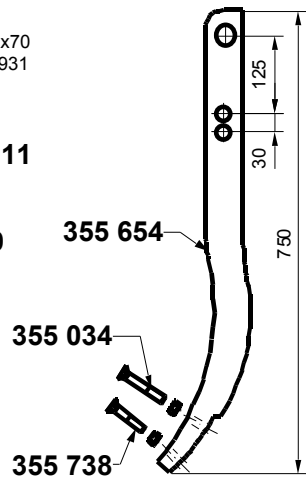

Typ

Scheibengrubber

Baugruppe

Zudeckscheiben

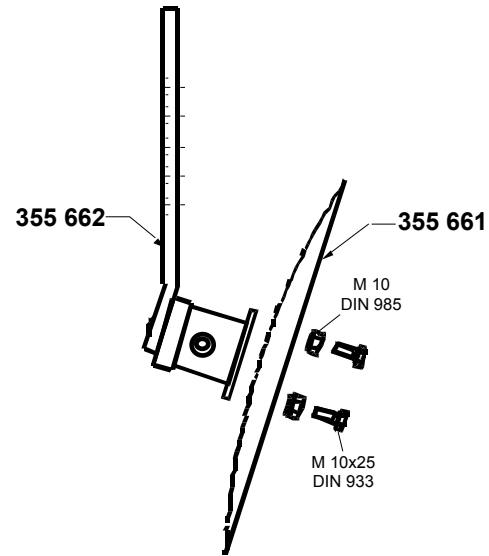
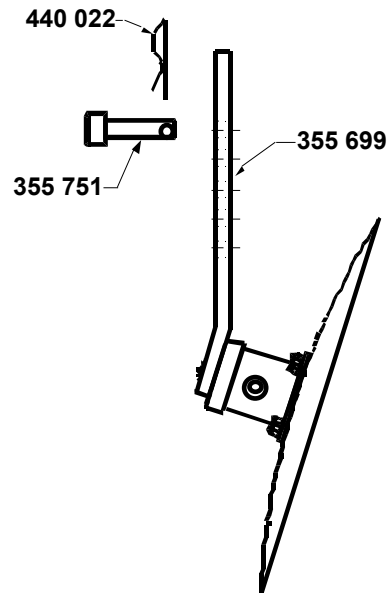

Zudeckscheibe

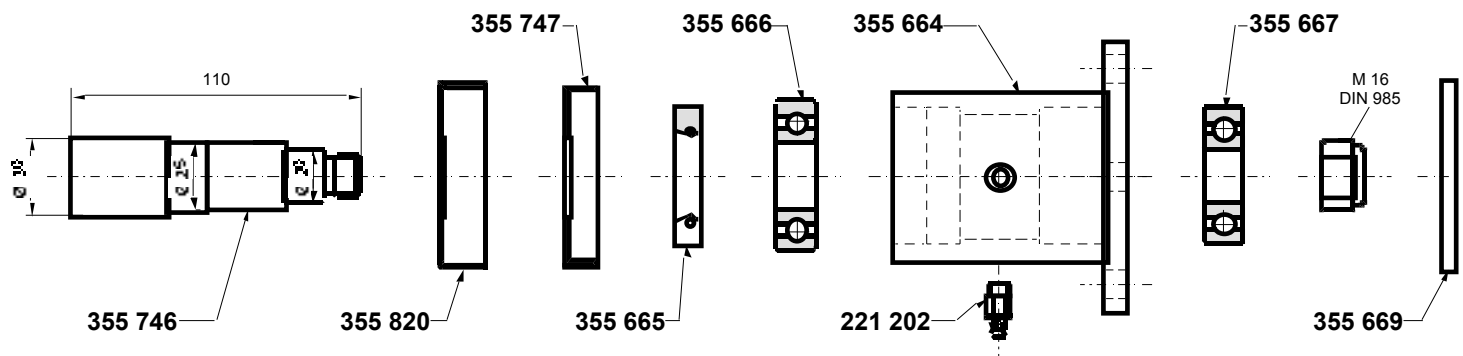
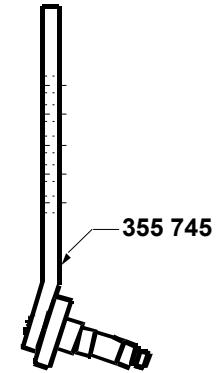

Typ

Baugruppe

Scheibengrubber

Scheibenhalter '98

Scheibenhalter '98

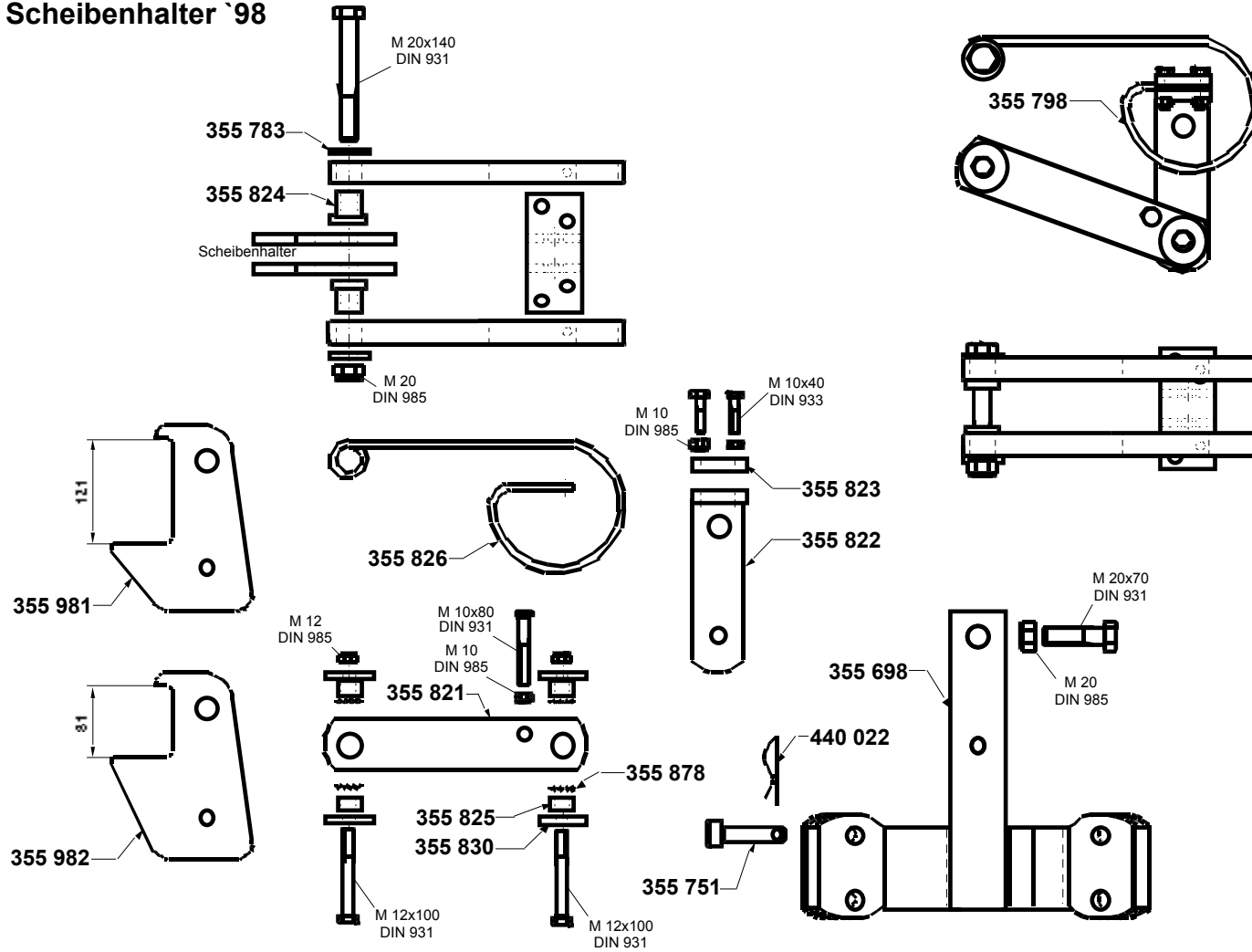

Typ

Scheibengrubber

Baugruppe

Randscheiben

Randscheibe klappbar

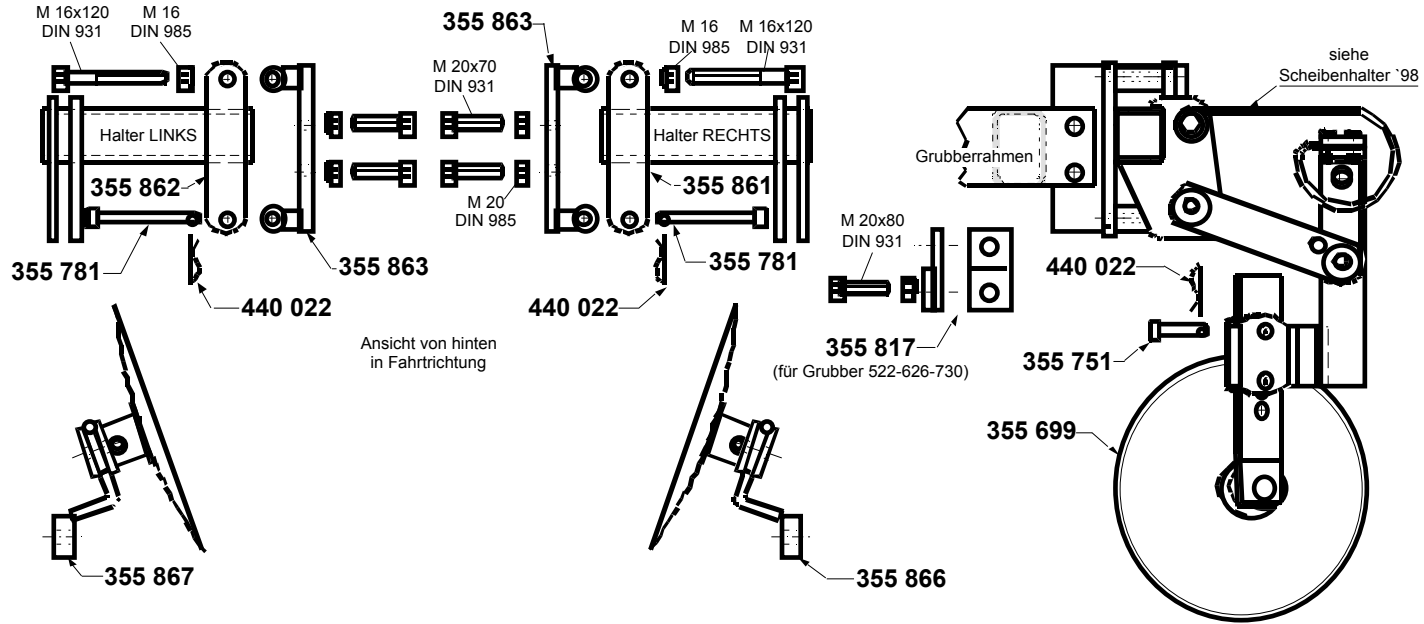

Randscheibe starr

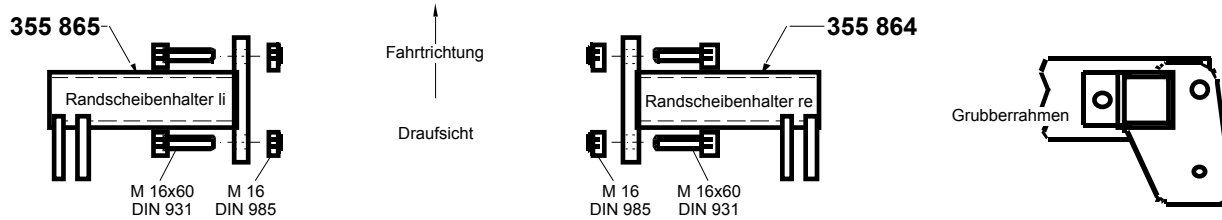

Typ

Scheibengrubber

Baugruppe

Rohrwalze

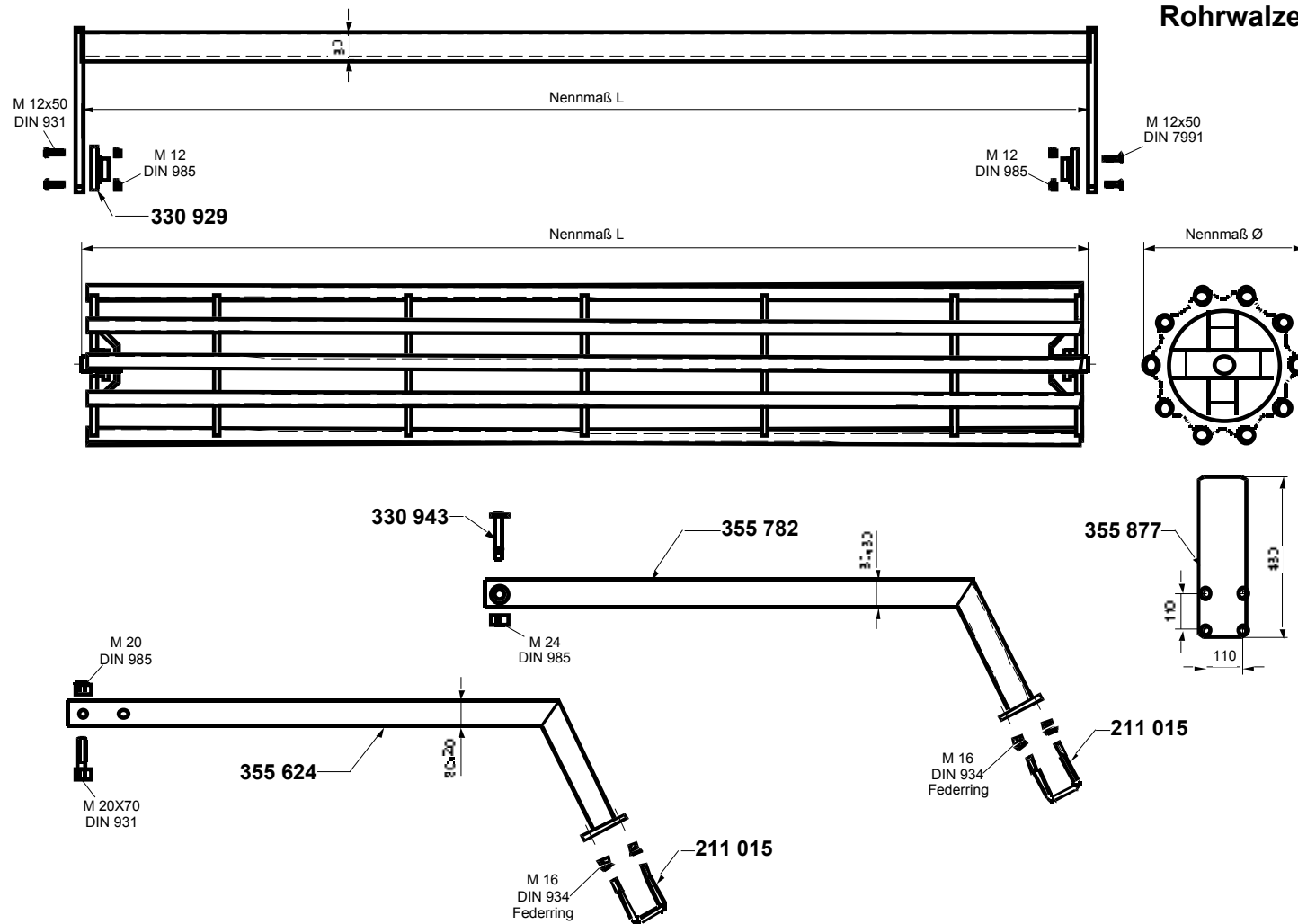

Typ

Scheibengrubber

Baugruppe

Rohrwalze

Bestell.-Nr	Benennung	
	Rahmen für Rohrwalze Ø 480 ohne Lager	
355 797	Rahmen 550	
355 799	Rahmen 950	
355 515	Rahmen 1400	
358 317	80er Rohr-Rahmen ohne Lager 2300/480	
358 319	80er Rohr-Rahmen ohne Lager 2700/480	
355 983	Rahmen 80 x 8 x 2900	
358 320	80er Rohr-Rahmen ohne Lager 3000/480	
	Rohrwalze Ø 480 ohne Rahmen	
355 794	Rohrwalze 480/550	
355 795	Rohrwalze 480/950	
355 796	Rohrwalze 480/1400	
358 303	RP 480 Ø / 2300 ohne Rahmen	
358 305	RP 480 Ø / 2700 ohne Rahmen	
355 715	Rohrwalze 480 x 2900	
358 306	RP 480 Ø / 3000 ohne Rahmen	
	Anbauteile	
355 624	Trägerarm mit Platte f. RW	
355 782	Trägerarm mit Platte	
211 015	Schraubbügel M16 LW81-LH115	
330 943	Gelenkbolzen M 24 25 x 135	
355 877	Lagerplatte 4-Loch - RP	
330 929	Flanschlager UCF 210 / NP 50	

Bestell.-Nr	Benennung	
	Rahmen für Rohrwalze Ø 400 ohne Lager	
355 984	Rahmen 80 x 5 x 550	
355 985	Rahmen 80 x 5 x 950	
355 986	Rahmen 80 x 5 x 1400	
358 325	80er Rohr-Rahmen ohne Lager 2300/400	
358 327	80er Rohr-Rahmen ohne Lager 2700/400	
355 987	Rahmen 80 x 5 x 2900	
358 328	80er Rohr-Rahmen ohne Lager 3000/400	
	Rohrwalze Ø 400 ohne Rahmen	
355 988	Rohrwalze Ø 400 / 550	
358 371	RP 400 Ø / 950 o. Rahmen	
355 989	Rohrwalze Ø 400 / 1400	
358 310	RP 400 Ø / 2100 o. Rahmen	
358 312	RP 400 Ø / 2700 o. Rahmen	
355 713	Rohrwalze 400 x 2900	
358 313	RP 400 Ø / 3000 o. Rahmen	

Typ

Scheibengrubber

Baugruppe

Spiralwalze

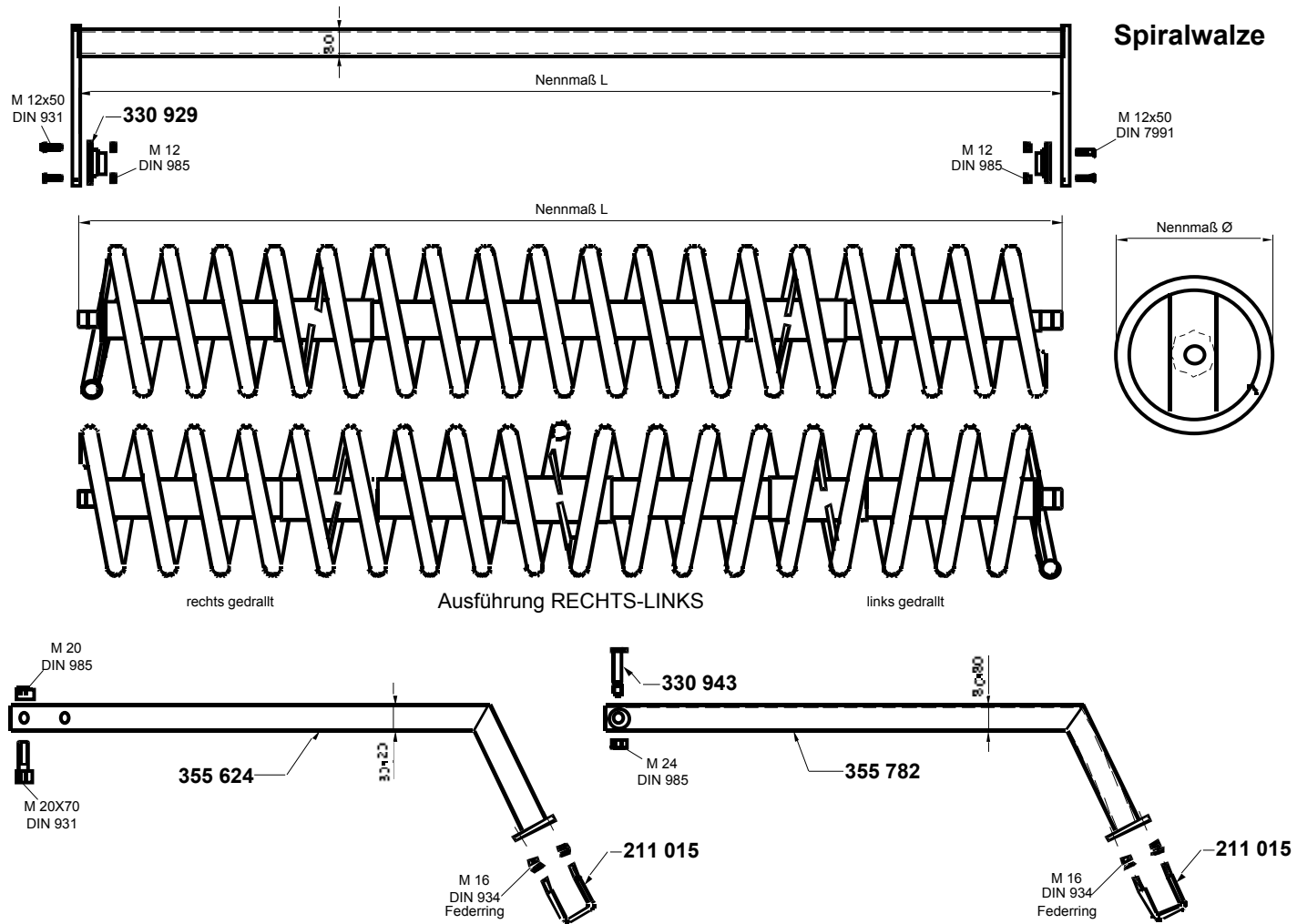

Typ

Scheibengrubber

Baugruppe

Doppelwalze

Doppelwalze

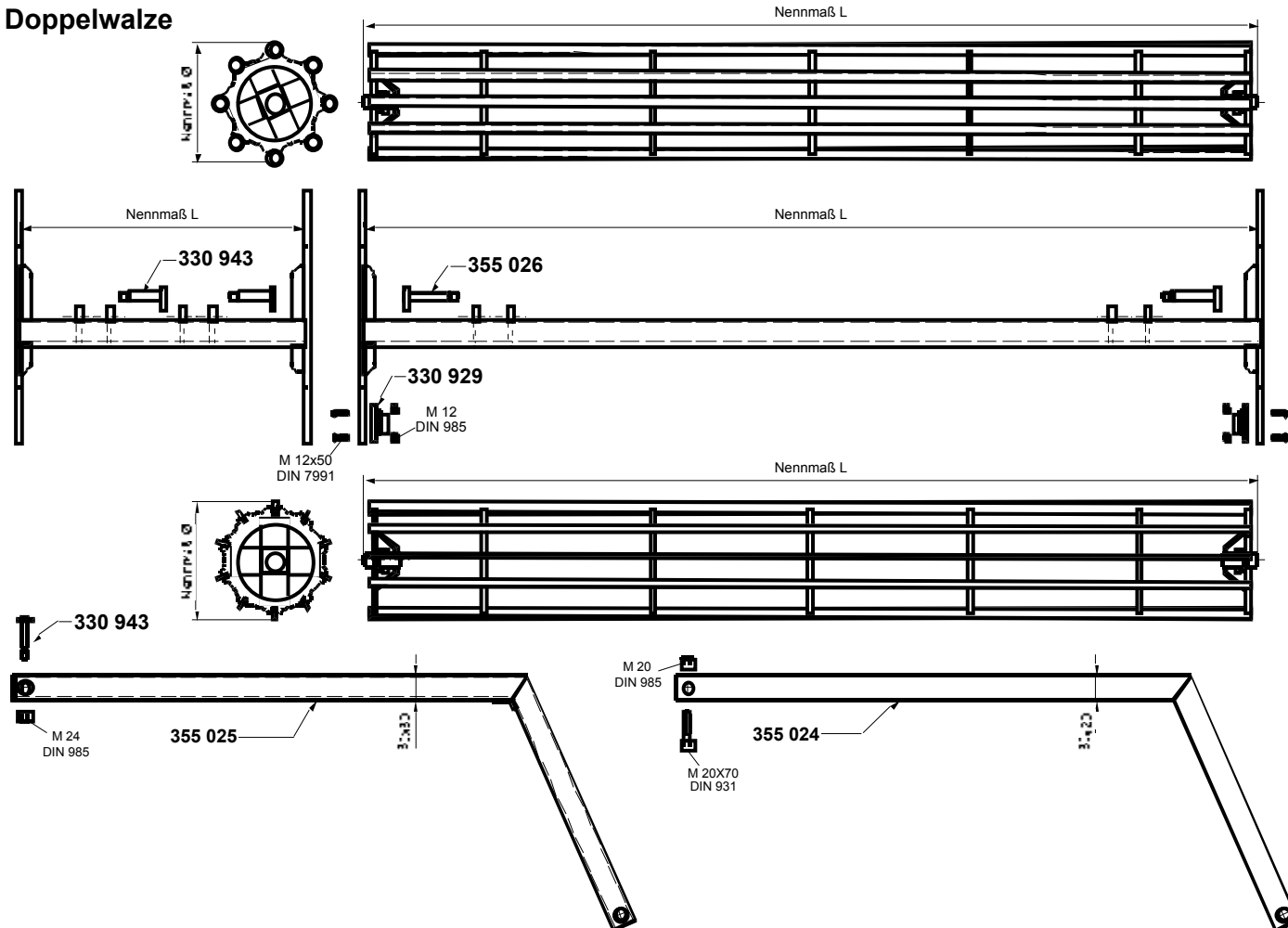

Typ

Baugruppe

Scheibengrubber

Goliath

System Goliath

